

GTI
Sub-6GHz 5G
Pre-Commercial Trial
White Paper

GTI

<http://www.gtigroup.org>

GTI Sub-6GHz 5G Pre-Commercial Trial White Paper



Version:	V1.2
Deliverable Type	<input type="checkbox"/> Procedural Document <input checked="" type="checkbox"/> Working Document
Confidential Level	<input checked="" type="checkbox"/> Open to GTI Operator Members <input checked="" type="checkbox"/> Open to GTI Partners <input type="checkbox"/> Open to Public
Working Group	Network Working Group
Task	Task-N-PM2-PJ1-3: Pre-commercial trial
Source members	Tan Sile
Support members	Zhu Zhenlei, Zhao Zhuyan, Ding Yi, Chen Jie
Editor	Huawei, Ericsson, Nokia, ZTE, CICT
Last Edit Date	22-10-2019
Approval Date	DD-02-2019

Confidentiality: This document may contain information that is confidential and access to this document is restricted to the persons listed in the Confidential Level. This document may not be used, disclosed or reproduced, in whole or in part, without the prior written authorization of GTI, and those so authorized may only use this document for the purpose consistent with the authorization. GTI disclaims any liability for the accuracy or completeness or timeliness of the information contained in this document. The information contained in this document may be subject to change without prior notice.

Document History

Date	Meeting #	Version #	Revision Contents
31-10-2018		v0.1	First Draft with skeleton only
14-12-2018		v0.3	Initial draft of GTI Sub-6GHz 5G Pre-Commercial WP for task member review
03-01-2019		V0.9	Completed draft for sub-6GHz project group review
25-01-2019		V1.0	Finalized Revision for GTI approval
11-02-2019		V1.1	Revised according to the comments from GTI members
22-10-2019		V1.2	Add Section 7.5 by new member's contribution. Update 5GIndustry progress accordingly.

Table of Contents

1	Abbreviations	5
2	Overview	7
3	5G Industry Progress	7
3.1	Standard Progress	7
3.2	Global Spectrum Auction Progress.....	8
3.3	Chips and Terminals Progress.....	9
3.4	Large Scale Trial progress and Use Case	10
4	Target Network Architecture.....	11
4.1	Network Architecture Strategy: SA or NSA.....	11
4.2	CU/DU Splitting and Edge Cloud	12
4.3	Network Synchronization	14
5	Key Solutions of pre-commercial Network	19
5.1	Massive MIMO Solution	19
5.1.1	Massive MIMO Performance Advantage	19
5.1.2	Key Features Proposed for Massive MIMO.....	21
5.1.3	3D Massive MIMO Gain.....	22
5.1.4	Easy-to-Deploy Massive MIMO.....	22
5.2	Coverage Enhancement Solution	23
5.2.1	EN-DC.....	24
5.2.2	Inter-Band DL CA	25
5.2.3	Supplementary UL (SUL).....	25
5.3	Mobility Solution.....	25
5.4	Voice Solution.....	27
5.5	Low Latency Solution for eMBB	30
6	Network Deployment Strategy	33
6.1	Service Selection and Requirements.....	33
6.2	5G Networking Suggestions	34
7	Large-Scale Pre-commercial Trial Result Sharing	36
7.1	5G Pre-commercial Trial in Hangzhou	36
7.1.1	Overview of Trial in Hangzhou	36
7.1.2	Network Deployment and Architecture	37
7.1.3	Trial Results of Performance	37
7.1.4	Validation of Easy Deployment.....	38
7.1.5	Trial Cases of 5G New Services	39
7.2	5G Pre-commercial Trial in Guangzhou	39
7.2.1	Overview of Trial in Guangzhou.....	39
7.2.2	Network Deployment and Architecture	40

7.2.3	Trial Results of Performance	40
7.2.4	Trial Cases of 5G New Services	41
7.3	5G Pre-commercial Trial in Suzhou	42
7.3.1	Overview of Trial in Suzhou	42
7.3.2	Multiband Propagation Capability.....	43
7.3.3	1/4 SSB Coverage Comparison.....	43
7.4	5G Pre-commercial Trial in Shanghai.....	44
7.4.1	Overview of Trial in Shanghai	44
7.4.2	Network Deployment and Architecture	44
7.4.3	Trial Results of CU/DU Splitting and Edge Cloud	45
7.5	5G Pre-commercial Trial in Wuhan.....	47
7.5.1	Overview of Trial in Wuhan	47
7.5.2	Network Deployment and Architecture	48
7.5.3	Trial Results of Performance.....	48
7.5.4	Trial Cases of 5G New Services	50
8	Summary	51

1 Abbreviations

Abbreviation	Explanation
2/3G	The 2/3rd Generation Telecommunication Technology
3GPP	The 3rd Generation Partnership Project
4G	The 4th Generation Telecommunication Technology
5G	The 5th Generation Telecommunication Technology
AR	Augmented Reality
CC	Component Carrier
CP	Control Plane
CPE	Customer Premise Equipment
DC	Dual Connectivity
eMBB	Enhanced Mobile Broadband
gNodeB	NR node

Abbreviation	Explanation
IPv4	Internet Protocol version 4
IPv6	Internet Protocol version 6
MIMO	Multiple-Input Multiple-Output
mMTC	Massive Machine Type Communication
mmWave	Millimeter Wave
MR	Mixed Reality
MU-MIMO	Multi-User MIMO
NAS	Non Access Stratum
NG Core	Next Generation Core Network
NR	New Radio
NSA	Non-Standalone
OFDM	Orthogonal Frequency Division Multiplexing
PLMN	Public Land Mobile Network
PoC	Proof of Concept
RLC	Radio Link Control
RRC	Radio Resource Control
SA	Standalone
UE	User Equipment
UP	User Plane
URLLC	Ultra-Reliable and Low Latency Communications
VR	Virtual Reality

2 Overview

5G brings people unlimited expectations. It will not only push mobile broadband services to new heights, but also foster new businesses, promote the digitization of various industries, greatly change people's existing ways of living and working, improve communication efficiency, and even change the pattern of mobile communication industry and the society.

In 2018, with the completion of 3GPP NR NSA& SA standards and the provisioning of 5G spectrum in some countries, 5G has got the momentum and gradually matured in equipment, terminals, applications and other aspects. The government, organizations and institutes, operators, equipment vendors, terminal manufacturers and the various vertical industry partners have actively carried out 5G pre-commercial deployment around the world, with the business incubation and application demonstration, which has greatly promoted the maturity of the whole industry.

GTI, as an industry consortium, together with its worldwide partners has actively participated in the 5G scale pre-commercial trials around the world. This white paper will serve as a platform to share and present the results of the test and the strategies of the deployment, thus provide a reference to industry partners, so as to jointly promote the 5G industry maturity, drive its scale commercialization, and embrace the property of 5G ecosystem.

3 5G Industry Progress

3.1 Standard Progress

As agreed in accelerated 5G time plan (endorsed in RP-170741), the early completion of the Non-standalone (NSA) 5G NR specifications (so called Option-3) was finished in December 2017, and corresponding ASN.1 was frozen in March 2018 for the enhanced Mobile BroadBand (eMBB) use-case mainly. The version which contains Standalone 5G NR (so called Option-2) was functionally frozen in June 2018, and the ASN.1 was frozen in September 2018. Additional Change Requests were approved at recent RAN meetings which make these specifications more mature and will provide a stable base for early 5G deployment.

For other NR architecture options, the plan was proposed in RAN#79 as 'late' drop, which contains additional migration architectures (so called Option-4, Option-7). In recent RAN meeting, its' ASN.1 review and RAN4 core requirements completed, which was slightly later than expected in the beginning. This will not impact any early NR deployment.

3.2 Global Spectrum Auction Progress

5G will be commercial in 2020 in many countries. Currently some of the countries have concluded their 5G spectrum auctions. This section summarizes the global status of spectrum auctions from different regions.

In Asia: Some countries have completed their 5G spectrum auction or assignment and some are preparing for that.

Korea: Completed 3.5 GHz auction on June, 2018, with 80-100 MHz per operator. LGU+ got 3420-3500 MHz, KT got 3500-3600 MHz and SKT got 3600-3700 MHz.

China: MIIT has published a notification on the 3300-3600 MHz and 4800-5000 MHz bands, to be used for 5G systems. 3300-3400 MHz frequency band is "limited to indoor use in principle." The assignment of the 5G mid-band spectrum has been completed. CMCC got 160 MHz in 2.6 GHz (in this 160 MHz, 60 MHz is their owned spectrum already used for LTE), and they got 100 MHz in 4.9 GHz (4800-4900 MHz). China Telecom got 100 MHz in 3.5 GHz band (3400-3500 MHz). China Unicom got 100 MHz in 3.5 GHz band (3500-3600 MHz) .

Japan: 3600-4200 MHz: Allocate 5 x 100 MHz of 3.7 GHz and 1 x 100 MHz of 4.5 GHz for operators. Each operator can apply up to 200 MHz CBW in 3.7/4.5 GHz. Applications for beauty contest will be accepted from January to February 2019, and spectrum awarded in March 2019.

In Europe, many countries have completed their 5G spectrum auction and some are preparing for coming auctions, for example:

Austria: Auction planned October 2018 for 3410-3800 MHz

Finland: Auction finished in Oct, 2018. All C-band spectrum is licensed to operators.

France: 3460-3800 MHz will be available for 5G by 2020, and auction is planned in 2019-2020 time frame.

Germany: Will auction 3400-3700 MHz to mobile operators in Q2 2019.

Ireland: 3400-3800 MHz was auctioned in May, 2017.

Italy: 3.6-3.8 GHz was auctioned in Oct, 2018 with a very high price.

Spain: 3.6-3.8 GHz auction was finished in July, 2018. 3.4-3.6 GHz was already owned by operators. Rearrangement is possible to get 3.4-3.8 GHz with contiguous spectrum for operators.

Sweden: 3400-3800 MHz will be auctioned in 2019.

U.K.: 3410-3480 MHz and 3500-3580 MHz was auctioned in April 2018. 3.6-3.8 GHz auction of the remaining 116 MHz by 2019 is proposed.

North America:

USA: 3.55-3.7 GHz: CBRS band. FCC has indicated that an order (final technical and service rules) will be issued in Sept 2018 addressing key outstanding issues. The latest guidance will be in the middle of 2019.

Canada: 3475-3650 MHz and 3650-3700 MHz will be licensed in 2020.

3.3 Chips and Terminals Progress

Huawei, Qualcomm, Samsung as well as other manufacturers actively join in 5G baseband chips and terminals R&D to promote the maturity of the 5G industry chain, with commercial deployment capabilities in 2019.

- **Chips:** Qualcomm, Hisilicon and Samsung released 5G commercial chips at the end of 2018. And MediaTek also released 5G baseband chips in 2019.

Supplier	5G Baseband Chips	Released Date
Qualcomm	Sanpdragon X50	Late 2018
Hisilicon	Balong 5000	Late 2018
Samsung	Exynos 5100	Late 2018
MediaTek	Helio M70	2019

- **Terminals:** Huawei released world first 5G CPE in 2018. And 20+ vendors, such as Samsung, Huawei, and Xiaomi, have released 5G commercial mobile phones in 2019. In the early stage of 5G development, fixed terminals such as CPE have lower requirements on terminal size and power consumption. As long as the cost is reduced to a certain level and the product is stable, the terminal can go to market in large scale. CPE and other 5G fixed terminals are expected to mature before the end of 2019. Mobile terminals are prone to mature in a long term due to their size, weight and power consumption. 5G mobile phones platform based on 7-10nm manufacturing process and independent baseband chips is expected to be commercially available in 2019, as Samsung, Huawei, Xiaomi, OPPO and VIVO announced. 5G mobile phones platform based on SoC multi-mode chip is expected to be commercialized in the second half of 2020. In the future, with the development of terminal R&D, especially the design of new RF front-end technology will be adopted; small wearable 5G terminals and all-band 5G mobile phones are expected to mature in 2021.

Korea jointly issued a statement that they will launch 5G commercial network in March 2019.

- In Japan, operators have also tested typical 5G eMBB use cases, such as virtual reality. The Ministry of Internal Affairs and Communications (MIC) released the 5G spectrum strategy in 2018, and plans to release the spectrum in 2019. 5G network will be officially commercialized before the Tokyo Olympic Games in 2020.
- In UK, telecom operator BT announced in May 2018 that it would launch 5G commercial services in 2019, actively exploring value-added services such as smart home broadband.

Country	5G Spectrum	Licensed Date	Use Case
China	2.6 GHz 4.8 GHz~4.9 GHz 3.4 GHz~3.6 GHz	2018/2019	Virtual reality, automatic drive, smart manufacturing, and smart city
USA	2.6 GHz	Before 2018	UHD Video
South Korea	3.4 GHz~3.7 GHz	2018	Virtual reality (Pyeongchang Winter Olympics 2018)
Japan	3.6 GHz~4.2 GHz 4.4 GHz~4.9 GHz	2019	Virtual reality (Tokyo Olympic Games 2020), automatic drive, and smart manufacturing
UK	3.4 GHz~3.6 GHz	2018	Smart home broadband

4 Target Network Architecture

4.1 Network Architecture Strategy: SA or NSA

In order to introduce NR technology quickly and evolve smoothly, 3GPP defines several architecture options. In Release 15, option 3 (NSA) has been finished on Mar. 2018, and option 2 (SA) on Jun. at first. Other options are planned as contents for R15 ext. e.g. options 4, 5, and 7. However, too many options permutate with one another, resulting in: higher cost, interoperability risks and fragmentation, and drive LTE RAN and device complexity. So far, option 3 and option 2 are mainly focused by operators. Their NR RAN architectures are shown below.

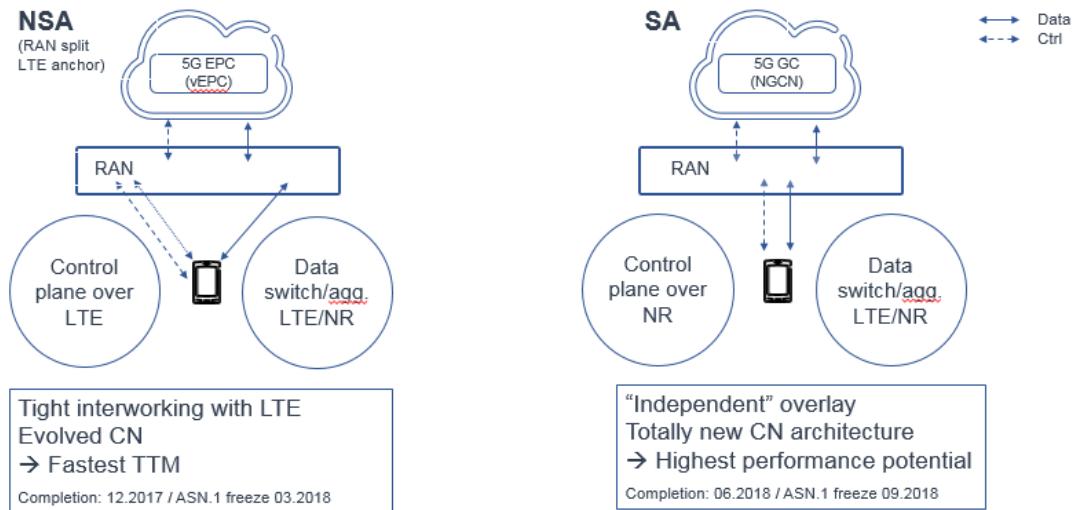

Figure 4-1 NSA & SA Architecture

NSA – easy inclusion of NR carriers in early deployments. No need for new core. Control plane, idle mode and mobility handling on well proven LTE in "low" bands.

SA – New control plane and new core -> get all the NR benefits. For high bands a dual connectivity configuration with lower bands good for robustness.

In general, dual band connectivity is good (especially when one band is a high band). Both NSA and SA can achieve this.

Most likely NSA is a very good place to start when adding NR capabilities to the networks. In the longer term, SA with inter-band carrier aggregation between different NR bands, is the way to go. It is in many cases an evolution from NSA to SA as "ultimate goal."

4.2 CU/DU Splitting and Edge Cloud

With the imminence of advanced use cases and 5G, e.g. typically new realities with AR/VR experiences, low latency will become a clear requirement, also as data traffic grows, increasing transport requirements. It should leverage on the Edge Cloud technology distributed across the radio access network for efficient computing and storage, optimally serve for different traffic scenarios.

1. The Edge Cloud distributes the generic compute capabilities throughout the network, taking it closer to where the traffic originates from.
2. The Edge Cloud is built on layered architecture with centralized and regional data centers combined with smaller edge and far-edge data centers.
3. Provides low latency and high processing power as required by applications like Cloud RAN.

As shown in Figure 4-2, applications and VNFs (Virtual Network Functions) will be distributed

across the layers based on their requirements and characteristics. Applications that do not require low latency or a high data throughput will be most likely placed on centralized or regional data centers, while the most demanding workloads will go to the edge.

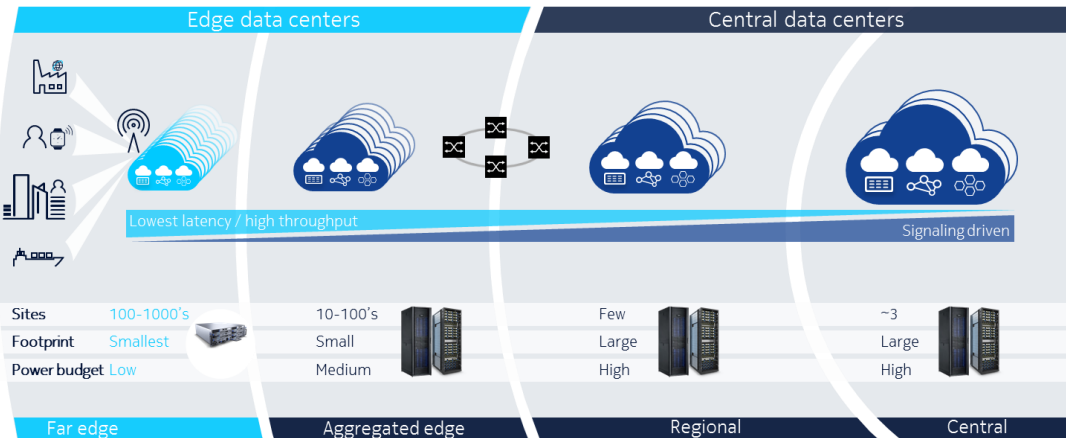

Figure 4-2 Layered architecture for efficiency and real-time performance

In order to allow flexible deployments of 5G RAN (with especially some functional entities in the cloud), 3GPP has introduced a new standardized interface F1 between a Centralized Unit (CU) and a Distributed Unit (DU). F1 is the interface being between PDCP/L2 high (handled in CU) and RLC/L2 low (handled in DU) layers. With CU/DU splitting and CU/DU integrated in DU, RAN deployment architecture can be divided into Cloud BTS and Classical BTS.

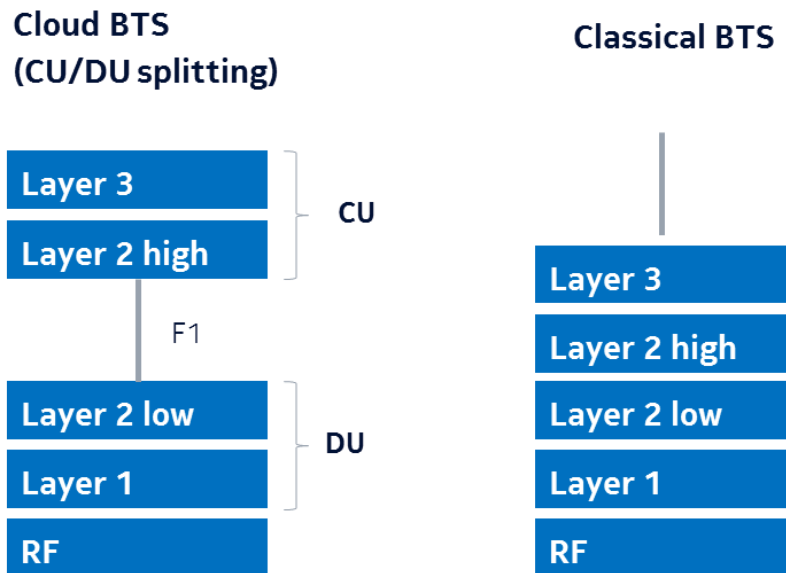

Figure 4-3 Cloud BTS (CU/DU splitting) and Classical BTS

The Cloud RAN Solution enables transformation from RAN product specific HW towards data center solution shared with other telecom services, and Cloud RAN will be deployed as a

virtual network functions of edge cloud. Benefits as:

- Network functions on standard IT HW
- Automated network function deployment
- Network function scalability and fast end to end service creation

Cloud RAN enable CSP reduce the network CAPEX and OPEX and cost and via integrate with functions/applications in edge cloud platform e.g. UPF, edge application and AI, enable new services in 5G.

Year 2018 has been the year of commercialization of Cloud RAN. Many successful field trials with operators took place e.g. with Verizon, China Mobile, Orange, Chunghwa Telecom etc, and the major field trials act as proof-points that the technology is ready for commercial rollouts.

4.3 Network Synchronization

Regarding 5G macro-cell network development in TDD, there are some observations:

- Most countries of the world can make available about 200-400 MHz of spectrum from C-band for multiple MNOs using TDD mode.
- MNOs may jointly deploy C-Band 5G networks with existing low frequency 4G networks.
- There are legacy LTE networks deployed in some markets, including Europe and Japan. Co-existence with legacy LTE networks may be a requirement there.

When there are multiple TDD networks operating in same area and in same frequency band without coordination, the transmitter side will interfere with the receiver side. The interference mainly comes from the out-of-band and spurious emission on the transmitter side and desensitize the sensitivity of the receiver, thus seriously affects system capacity. As described above, multiple MNOs will operate 5G networks in C-band. The interference between different networks is more likely to occur.

In order to alleviate the above problems, one way to avoid this issue is to synchronize networks operating in adjacent frequency carriers to make them transmit and receive at the same time. Network synchronization has been successfully implemented in 4G TDD networks ensuring efficient use of spectrum resources by avoiding guard bands between operators.

- **Synchronization of TDD networks operating in adjacent frequency carriers has been widely implemented in LTE TDD and CDMA networks supported by market-proved techniques.**

Different from FDD systems where frequency synchronization is generally sufficient, it is essential that the time and phase reference in TDD system is traceable to Coordinated Universal Time (UTC). Without the common UTC time reference cell sites cannot operate as intended. In the LTE-TDD system, two phase accuracy granularities are specified, 1.5 μ s and 5 μ s, corresponding to two cell radius sizes differentiated by 3 km. The following

table presents a summary of the synchronization requirements of different mobile network modes.

Frequency and phase synchronization requirements of different mobile network modes

Network Mode	Radio	
	Frequency Accuracy	Phase Accuracy
GSM, UMTS, WCDMA, and LTE-FDD	50 ppb	/
CDMA2000	50 ppb	$\pm 3 \mu s$ to $\pm 10 \mu s$
TD-SCDMA	50 ppb	$\pm 3 \mu s$
LTE-TDD	50 ppb	$\pm 1.5 \mu s$ (for cell radius ≤ 3 km)
	50 ppb	$\pm 5 \mu s$ (for cell radius > 3 km)
5G-NR	50 ppb	$\pm 1.5 \mu s$

Mature techniques like GNSS (global navigation satellite system) and IEEE 1588V2 have been widely deployed in telecommunication networks to support synchronization.

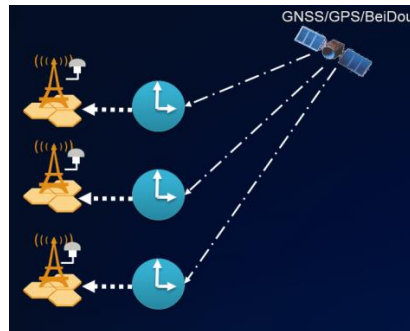

As shown in the preceding figure, GNSS signal receivers are directly deployed on terminals (base stations), and each base station acquires satellite time signals (GPS, Beidou, GLONASS, etc.) directly to achieve the time synchronization between different base stations and to keep the maximum deviation of any two base stations within 3 μs .

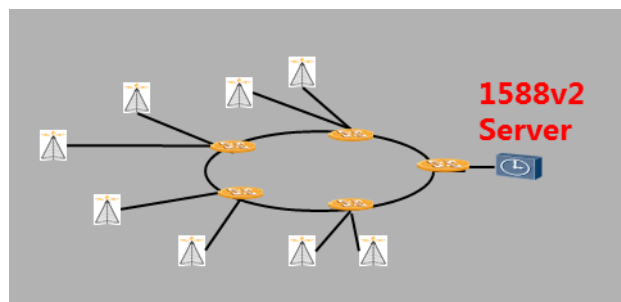

The IEEE protocol organization has proposed the IEEE 1588V2 accurate time transfer protocol, which can achieve sub-microsecond precision time synchronization like the current GPS currency. As shown in the preceding figure, the clock synchronization information of the main time source is transmitted through the 1588V2 protocol packet on the transmission network. The base station can obtain time information from the transmission network through the 1588V2 interface to achieve synchronization with the time source. The accuracy can reach ns level.

These two synchronization methods described above have been widely used by operators around the world. Each operator has different choices which depending on the country and the network situation. For example, operators in Japan and other regions mainly use type1 (GPS), and some operators in Europe choose type2 (IEEE 1588V2). Some other operators will also consider adopting a combination of two synchronization approaches to improve reliability (e.g. China Mobile).

- **Synchronization of 5G macro-cell networks: the best way to avoid interference between networks and save 25 MHz guard band.**

If 5G macro-cell networks are not synchronized, more than 25 MHz additional guard band together with additional transceiver filters would be required. Considering that a large portion of precious spectrum bandwidth would be unusable and the additional cost of BS equipment, it can be concluded that Guard Band is not a practical solution to address the interference for 5G macro-cell networks to be operated in C-band. The alignment of DL-UL ratio and frame synchronization in frame timing and frame format shall be kept the same.

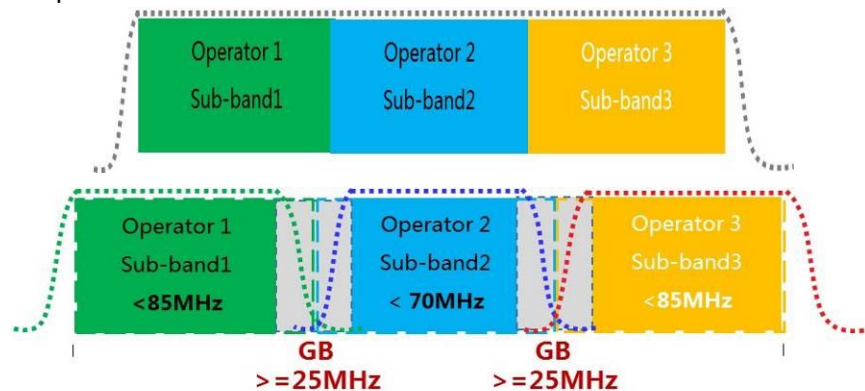

Figure 4-4 Synchronized & Unsynchronized operation

- **A single frame structure for synchronization of networks in C-band should be adopted for one country.**

We take some synchronization deployment practices for 5G macro-cell networks operating in the C-band, taking into account technology advances and system design requirements.

- **Scenario 1: C-band 5G only, no legacy LTE TDD network in the C-band**
Example: China, South Korea etc.

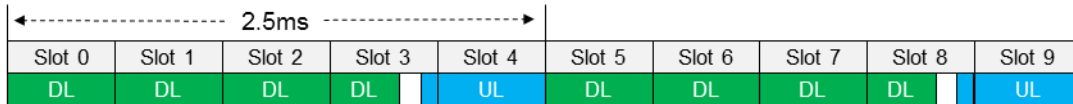

Figure 4-5 Frame structure of 2.5 ms-single DL/UL switching period

In terms of achieving better tradeoff between latency and overhead, the 2.5-ms DL/UL switching period is regarded as a proper choice. Thus, the corresponding frame structure depicted in the Figure 4-5 can be selected, i.e., each 5 slots consist of 3 DL-only slots, 1 UL-only slot and 1 DL-dominant special slot.

- **Scenario 2: C-band 5G only, no legacy LTE TDD network** in the C-band, UL capacity or coverage needs to be further improved

Example: China

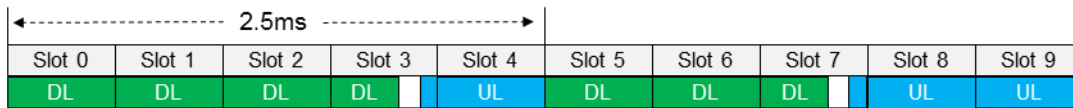
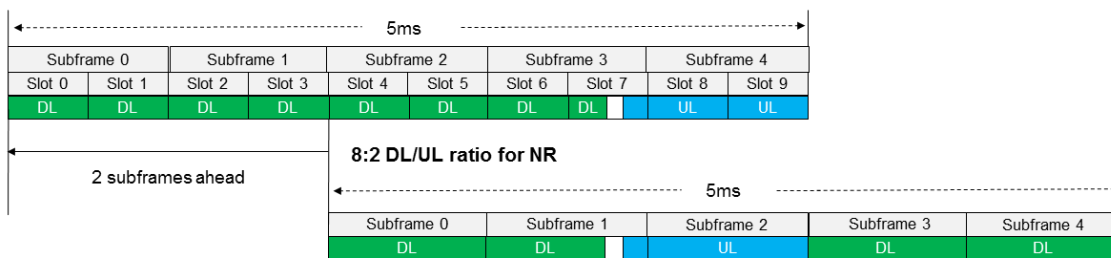

Figure 4-6 Frame structure of 2.5 ms-double DL/UL switching period

If UL capacity or coverage needs to be further improved, a straightforward approach can be used to increase the UL occupation ratio within the frame structure. Namely, the frame structure of 2.5 ms-double DL/UL switching period as shown in Figure 4-6 can be considered for the purpose of UL capacity or coverage enhancement whose corresponding DL/UL ratio is 3:1.

- **Scenario 3: co-existence with LTE TDD network**
- **Example: China, UK etc.**



TD-LTE frame configuration 2

Figure 4-7 Frame structure of 5 ms DL/UL switching period

For the operating band in which both NR and LTE are deployed, the aforementioned two frame structures cannot attain network synchronization between NR and LTE since LTE TDD frame configurations are not compatible with frame structures of 2.5-ms DL/UL switching period. For LTE TDD, frame configuration 2 is the most widely used frame structure, i.e., 3:1 DL/UL ratio with 5-ms DL/UL switching period.

Then, the frame structure of 8:2 DL/UL ratio with 5-ms DL/UL switching period can be adopted for NR to attain synchronization with LTE. In addition, the slot format configuration in NR is very flexible which can match all the configurations of special subframes in LTE. The only modification is to adjust the starting point of the frame as shown in Figure 4-7.

- **Telecommunication regulators have an important role in establishing consensus on synchronization of 5G networks among the stakeholders.**

Telecommunication regulators in China, Korea and UK have played a key role in establishing consensus among the concerned stakeholders and defined rules on synchronization of TDD networks in C-band, such as agreements on DL/UL time slot ratio and transmission frame structures.

- **China**

For the first 2.6 GHz TDD network in the world, China operators contributed many efforts to network coordination. Finally, under the guideline of MIIT (Ministry of Industry and Information Technology) of China, the synchronization among operators' networks at the band 2.6 GHz was implemented based on the same frame structure and the same DL/UL traffic ratio. China MIIT has been actively organizing MNOs and relevant stakeholders to negotiate a single frame structure for synchronization of 5G networks in 3.5 GHz band.

- **Korea**

Korea completed the 3.5 GHz and 28 GHz auction on June 18th with 80-100 MHz per MNO on 3.5 GHz:

LGU+:	3420-3500 MHz
KT:	3500-3600 MHz
SKT:	3600-3700 MHz

In addition, MSIP has determined that 5G adopts the synchronization network in the bands 3.5 GHz and 28 GHz with the same frame structure DDDSU.

- **UK**

On 11 July 2017, UK Ofcom issued auction regulations for the award of the 2.3 and 3.4 GHz spectrum bands and also updated Information Memorandum alongside the regulations. The updated Information Memorandum sets out the conditions of the licenses that will be issued for the 2.3 and 3.4 GHz bands respectively. The licenses are technology neutral and based on Time Division Duplex (TDD) mode. Licensees will be required to synchronize their networks in order to avoid interference to one another, so traffic alignment and the "Preferred Frame Structure" as in Figure 4-8 for transmission with the limits of the Permissive Transmission Mask are mandated to implement the synchronization. Timeslots must have a duration of 1 millisecond. TD-LTE frame configuration 2 (3:1) is compatible with this frame structure. Other details of the preferred frame structure can be found in paragraph 12 in the Information Memorandum.

DL/UL ratio	Subframe number									
	0	1	2	3	4	5	6	7	8	9
3:1	D	S	U	D	D	D	S	U	D	D

Figure 4-8 Preferred frame structure

Regulators in other countries are encouraged to take an active role with this aspect to facilitate 5G network development in their countries by making decision of a frame structure for synchronization of networks in the band.

5 Key Solutions of pre-commercial Network

5.1 Massive MIMO Solution

5.1.1 Massive MIMO Performance Advantage

- 1) **Massive MIMO is considered as one of the key technologies to increase spectral efficiency in 5G.**

A large number of antennas can be employed in a given aperture, which increases the capability of beamforming and MU-MIMO to satisfy rapid growth of capacity requirement.

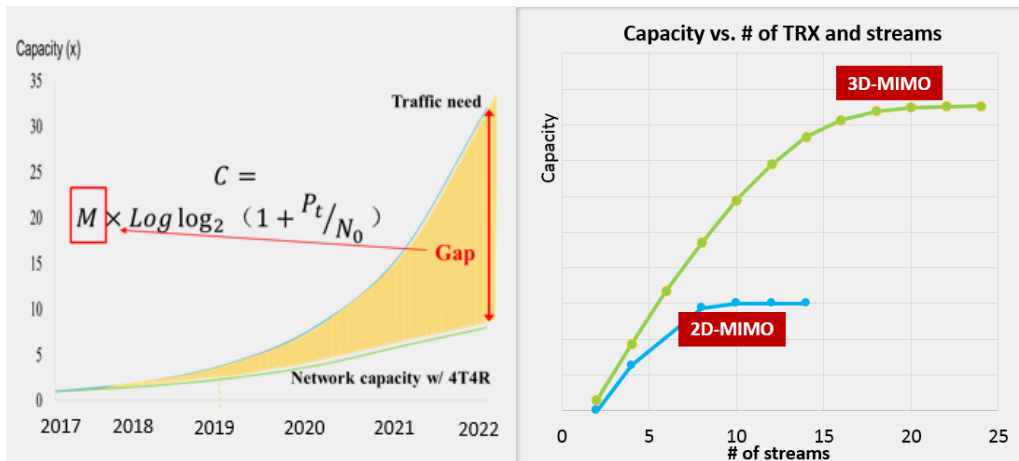

- 2) **All channels using 3D beamforming is one of basic principles in 5G to increase spectral efficiency.**

Regarding the NR common channel, it supports narrow-beam sweeping. The coverage of broadcast beam is completed by transmitting narrow beams in different directions at different times, and the cell coverage performance is improved significantly compared with the LTE wide-beam. NR supports beam coverage in different scenarios, such as

square scenarios and building scenarios.

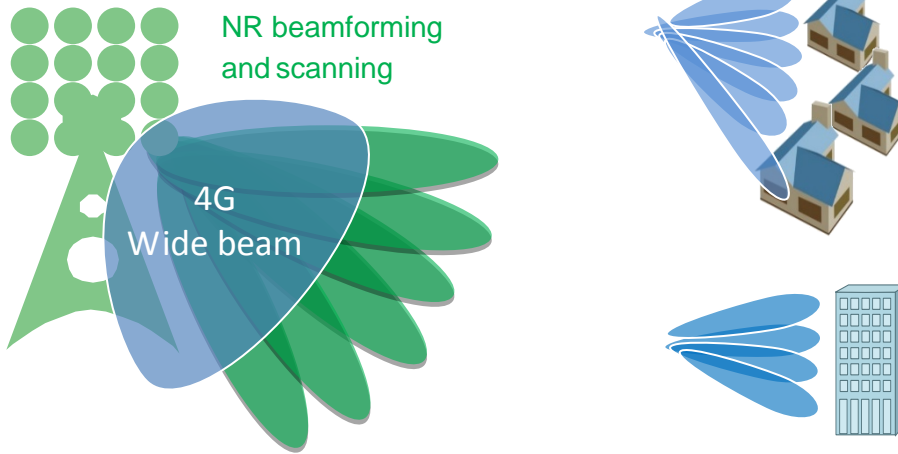

Regarding the traffic channel, NR narrow beams enable more users to participate in pairing. The more antenna TRX number is, the higher number of pairing layers can be achieved. More layers provide higher spectral efficiency and more capacity. 3D massive MIMO can provide vertical flexible beam to enhance coverage, especially for high building scenarios compared to traditional 2D-MIMO. Meantime, 3D massive MIMO can also provide more probability to make full use of horizontal and vertical spatial multiplexing.

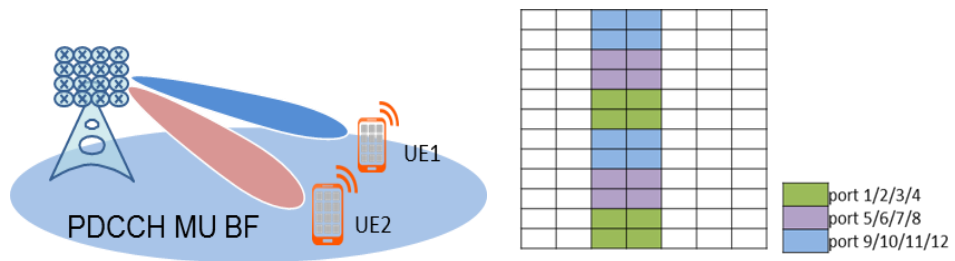

Regarding the control channel, PDCCH supports differentiating different users by the isolation between different sending beams, and completes PDCCH MU spatial multiplexing, which can improve the capacity of PDCCH and support scheduling more users. At the same time, NR supports up to 12 orthogonal DMRS ports to improve system capacity.

5.1.2 Key Features Proposed for Massive MIMO

1) **2T4R UE with SRS antenna switching capability is highly recommended.**

For sub-6 GHz band, if the spectrum allocations are of TDD type and digital beamforming solution is assumed. In this case, high-resolution CSI in the form of explicit channel estimations is acquired by UL channel sounding based on channel reciprocity. Such high-resolution CSI enables sophisticated precoding algorithms to be employed at the BS to improve spatial multiplexing performance. In addition, it is expected that the UE should at least have the TX/RX capability of 2T4R in NR because 2TX shows 65% uplink throughput gain compared with 1TX in link-level simulation. SRS switching shows additional 40% downlink throughput gain compared to non-switching case.

2) **UE with DMRS type 2 capability is highly recommended.**

To support these diverse use cases, NR features enhanced DMRS and a highly flexible CSI framework. 8 orthogonal DMRS ports for SU and up to 12 orthogonal DMRS ports for MU data transmission have been agreed for NR system.

3) **UE with type 2 codebook capability is highly recommended.**

On the other hand, CSI acquisition and interference measurement should be enhanced as well to support the high-order SU/MU data transmission. To improve CSI measurement and reporting, a high-resolution codebook design and an enhanced SRS design (that is, increased SRS ports) for reciprocity-based transmission are necessary in NR. Currently, type I codebook up to rank 8 and type II codebook for rank 1&2 have been supported. Codebook for Beamformed CSI-RS can be used for linear combination of multiple beams. Type 2 codebook based PMI provides 30%~50% capacity gain compared with type 1 codebook based PMI.

4) **Beam management for high band is recommended.**

The beam management is another feature in NR, which mainly prepared on analog beamforming for high band deployment. For sub-6 GHz band, digital beamforming is assumed at gNodeB side, which can use full aperture to create UE-specific beams, and process TX and RX beams in different directions simultaneously. Therefore, beam management is not needed in general. In case SS/PBCH is bottleneck on link budget, the beam sweeping procedure may be used to enhance SSB coverage on mid-band to provide suitable beam pattern for specific scenario.

5.1.3 3D Massive MIMO Gain

Compared with traditional 2D-MIMO with only one vertical beam, 3D massive MIMO provides gains on coverage, capacity, and user experience. In dense urban area with high building scenarios, compared with traditional 8T8R, 64T64R massive MIMO provides 3 to 5 times capacity, more than 8 dB coverage gain, and 45% user experience.

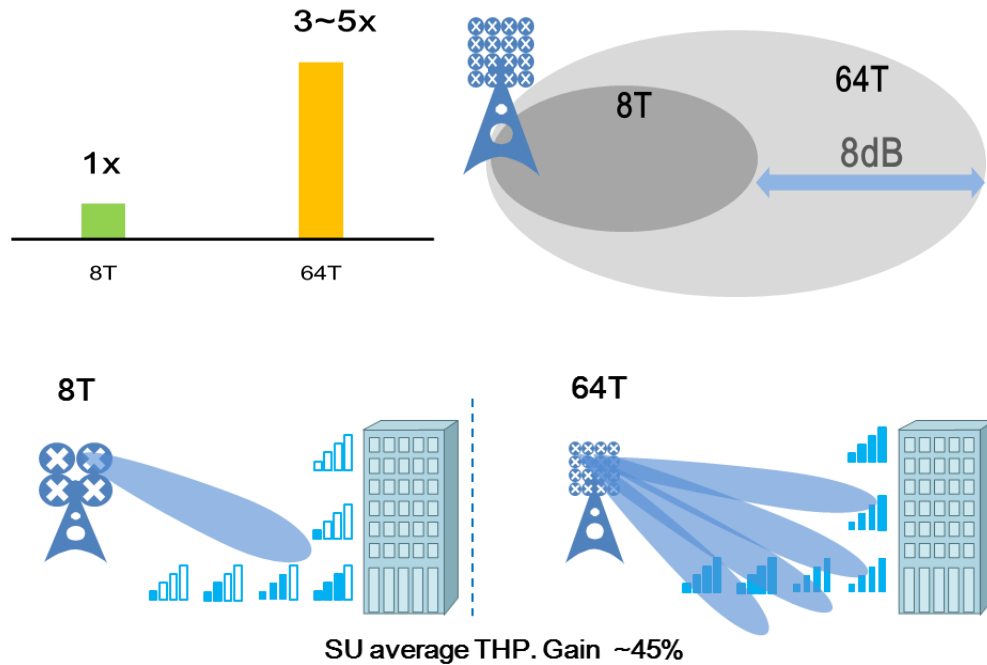

5.1.4 Easy-to-Deploy Massive MIMO

As massive MIMO module becomes smaller and lighter after generations of improvement, 5G massive MIMO modules can be easily installed in most scenarios, such as roof top pole, monopole, monitor pole, and wall mount. Only two engineers are needed for massive MIMO installation in general. Engineer A is adjusting the azimuth, tilt and height of the massive MIMO, and engineer B is monitoring and checking. At the same time the security risk is also low.

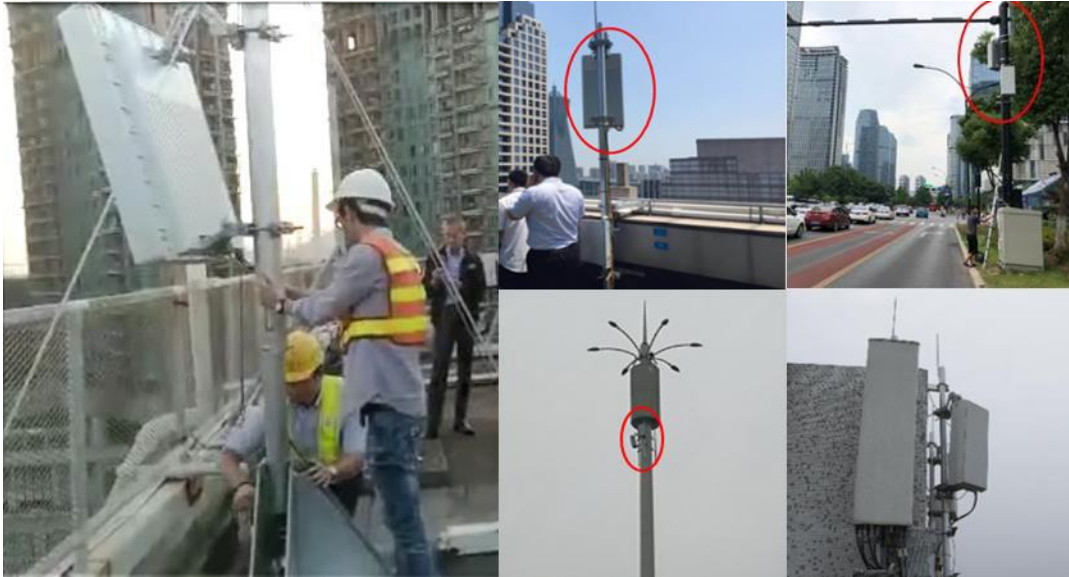

For single massive MIMO equipment, the largest proportion of cost is on PA, filter and IF chipset. However, the cost of massive MIMO module depends on the deployment scale. As the number of deployments increases, costs continue to fall and final target is 2 times of that of 8T8R RRU.

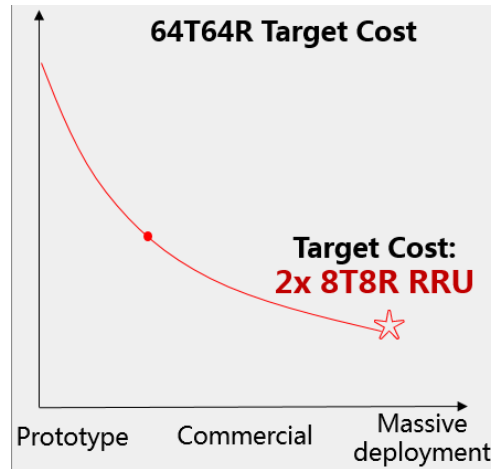

In summary, with large bandwidth, native MIMO design and large scale deployment, 5G massive MIMO enables 10X bit cost reduction.

5.2 Coverage Enhancement Solution

NR Coverage is similar with LTE that it is very much UL limited. Different UL channels such as PUSCH and PUCCH might be the final coverage limited key factors depends on the control or

data information that they carry and the channel implementation.

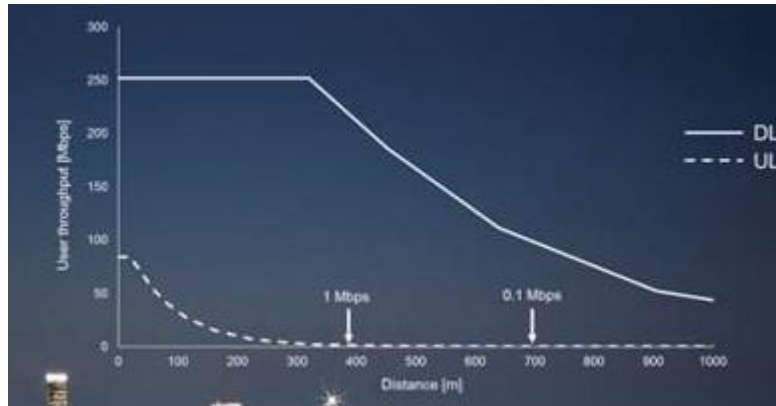

Depending on design choices, limited UL control channel can change. Specific design solutions such as long PUCCH, dynamic switching between wideband/sub-band CSI feedback and Msg3 retransmission can be used to boost the link budget for corresponding channels and therefore improve the coverage.

DL channels are not limiting NR coverage in general but can still be enhanced via different strategies:

- Beam-based transmission for control and data via DMRS-based channel estimation
- Different beam shapes for SS_block for various scenarios. NR also standardized the flexibility that multiple beams can be supported if needed.

Despite different designs for corresponding physical channels, mid/high band NR by nature is very limited on coverage. 3GPP defines that the following strategies can be used to enhance NR coverage:

- EN-DC
- Inter-band DL CA
- Supplementary UL

5.2.1 EN-DC

Uplink fallback to LTE is a very important functionality of dual connectivity. It allows DL to be transmitted on mid/high band NR, while using low band (mostly FDD) for coverage limited UL.



EN-DC benefits mid/high band NR coverage by means of moving the UL data to the low band LTE and therefore removes the UL PUSCH data as the bottleneck of the coverage concern. Due to the nature that NR UL control information is with much difference compared with LTE, that is, HARQ timing and CSI feedback, it is not possible to transmit NR UL control channel information on LTE UL, which rules out the further possibilities of making improvement on NR

mid/high band coverage.

5.2.2 Inter-Band DL CA

Inter-band DL carrier aggregation (CA) for SA and NSA scenarios can be supported.

For SA scenario, spectrum sharing should be supported for the low band LTE so that NR low band can be created at the same time via which NR carrier aggregation between mid/high band and low band can be achieved. Two DL carriers and one UL carrier (toggled in between two NR UL carriers) can be activated simultaneously.

For NSA scenario, one LTE anchor band exists and EN-DC is enabled. Meanwhile, similar with SA scenario, one NR UL and one DL carrier are created on another LTE band with the help of spectrum sharing, which makes the inter-band CA for NSA achievable.

Compared with EN-DC, it is possible to move most of the NR coverage limited UL channels to the low band NR channels that are created on top of the LTE band, which can be used to heavily boost the NR mid/high band coverage.

5.2.3 Supplementary UL (SUL)

In 3GPP Rel-15, supplementary UL (SUL) is defined to support configuration on 2 UL carriers for 1 DL of the same cell. The UL carrier in lower band (SUL) is used when UE is coverage limited. At any point in time UE transmits on only 1 UL carrier for one serving cell and which UL carrier to use is indicated from gNB.

For SA scenario, UL spectrum sharing should be supported for the low band LTE so that SUL can be created. Since no DL spectrum is required, there is no effects on LTE DL. With UL sharing on low band LTE, one NR UL carrier is created and used to be toggled with the NR mid/high band based on coverage. The supplementary UL is mainly utilized when the UE is outside the mid/high band NR coverage.

For NSA scenario, one LTE anchor band exists and EN-DC is enabled. Meanwhile, similar with SA scenario, one SUL is created on another LTE band with the help of UL sharing. Since LTE anchored band and SUL can be the same, 2 bands are required in this scenario.

5.3 Mobility Solution

NR mobility solution includes NSA and SA scenarios.

In NSA scenario, the EN-DC mobility procedure defined by 3GPP Rel-15 includes initial access, SgNB addition, SgNB modification, SgNB change, MN Handover with/without SN change and SgNB release, which can ensure UE service continuity and enjoy 5G service in 5G coverage zone.

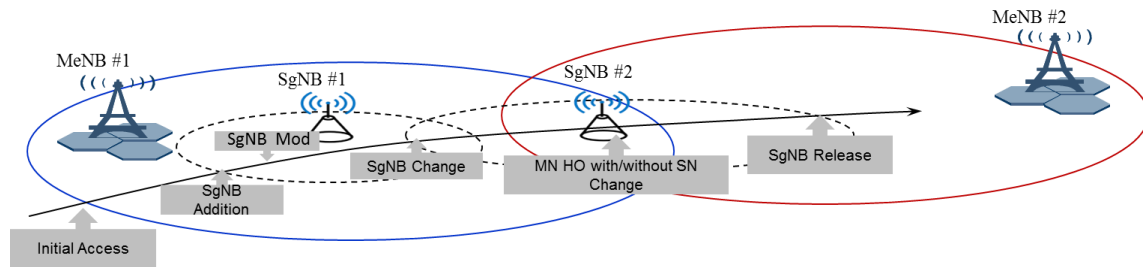

- Initial access: UE performs the attach procedure and accesses the LTE cell in MeNB#1.
- SgNB addition: When UE accesses the LTE cell, eNodeB triggers SgNB addition procedure, using B1 event to add NR cell.
- SgNB modification: When UE moves to the edge of PSCell, the network changes the PSCell of UE in the same SgNB#1, using measurement report.
- SgNB change: When UE moves to the edge of SgNB#1, the network changes the PSCell of UE from SgNB#1 to SgNB#2, using measurement report.
- MN Handover with/without SN change: When UE moves to the edge of MeNB#1, the network changes the PCell from MeNB#1 to MeNB#2. If UE is not out of coverage of SgNB#2 and SgNB#2 has a DC neighboring cell with MeNB#2, then the UE performs MN HO with SN change. Otherwise, MN HO without SN change is performed.
- SgNB release: When UE moves to the edge of SgNB#2 and it has no other SgNB coverage, then do the SgNB release procedure.

In SA scenario, 3GPP Rel-15 baseline mobility procedure adopts LTE basic HO procedures with beam handling enhancement. The baseline mobility includes cell level mobility (HO) and beam level mobility (intra-cell beam switch).

- Cell-level mobility requires explicit RRC signaling to be triggered and is based on the L3 cell level measurements. Cell level measurement is derived from an average over the cell's best beams above a threshold.
- Beam-level mobility does not require explicit RRC signaling to be triggered and is based on the L1 measurement of individual beams.

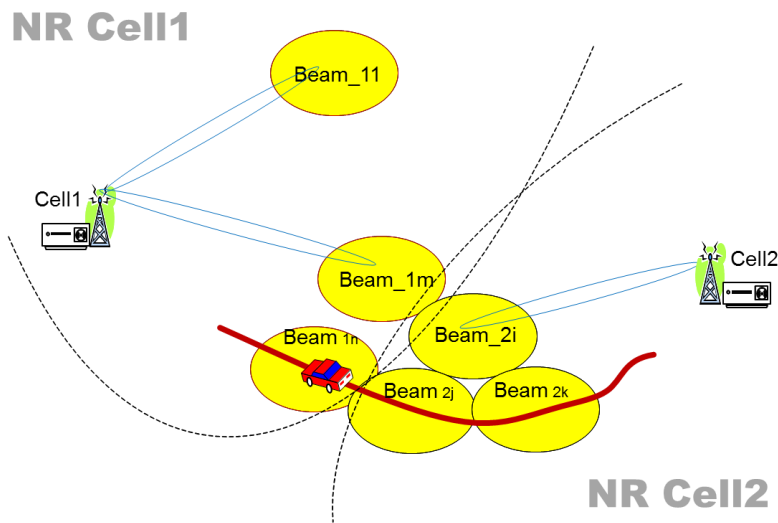

NR shall support handover as part of the NR mobility procedures. Handover is only possible after SRB2/DRB are established. Network-based mobility shall reuse the same principles as LTE and for inter gNodeB HO consisting of at least:

- Source gNodeB initiates the HO over the Xn/Ng interface via a HO request/required.
- Target gNodeB performs admission control and provides the RRC configuration as part of the HO acknowledgement.
- Source gNodeB provides the configuration to the UE including the HO command via RRC.
- The UE moves the connection to the target gNodeB via RRC.

Timer-based handover failure procedure like LTE (T304) is supported in NR. RRC connection re-establishment procedure should be used for recovering handover failure. For HO preparation, the source gNodeB selects the one candidate PCell for HO and the target gNodeB accept or rejects the HO preparation (as in LTE). The source gNodeB can provide additional preparation information including security information to be possibly used in the event of re-establishment.

3GPP defines the concept of 0 ms interruption during HO for mobility enhancement solution. In Rel-15, 0-ms interruption can be achieved in cases below:

- Intra-cell using beam mobility.
- For CA operation, addition and release of SCell in response to mobility. No change to PCell.

Solution of 0 ms interruption during HO in other cases will be discussed in Rel-16, such as intra-frequency or inter-frequency HO in SA, SgNB change in NSA.

5.4 Voice Solution

3GPP Rel-15 has determined that the 5G voice solution continues to use the 4G IMS voice

architecture. For the NSA architecture, existing 4G voice solutions can be utilized, including VoLTE and CSFB. For the SA architecture, 3GPP defines a new EPS FB process that supports voice fallback from 5G to 4G, simplifying the voice deployment of 5G SA initial stage. At the same time, in order to simplify the network and accelerate the exit of CS voice, 5G will no longer support the CS fallback to 2/3G. On the RAN side, related voice features have also been supported, such as ROHC, slot aggregation, DRX, SPS, and so on. In general, Rel-15 can meet the basic requirements of 5G voice commercial deployment. Rel-16 and later will further discuss functions related to 5G voice enhancement, such as SRVCC between 5G and 3G to meet the voice service continuity requirements of 4G-free scenarios, and further discussion on coverage enhancement and slicing.

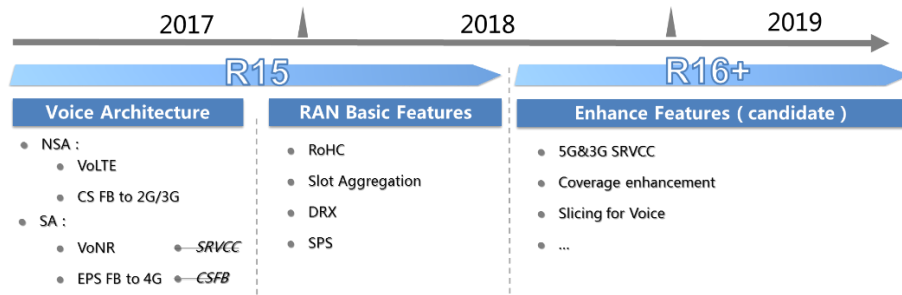

The VoNR for SA architecture is a target solution for 5G voice, which can bring a better user experience of ultra HD voice than 4G. Compared to 4G, it can only provide HD voice experience. According to the current voice deployment of 4G networks, operators can choose different routes to evolve to VoNR:

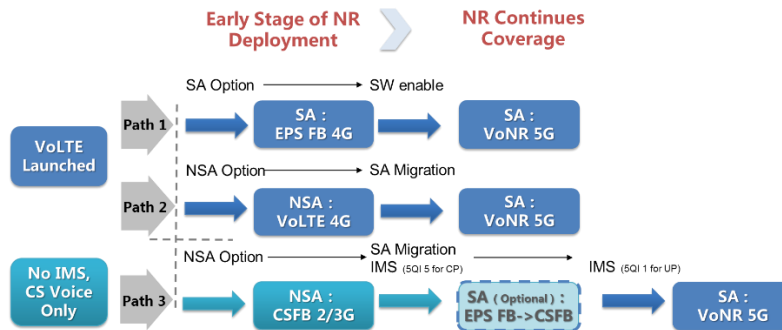

- Path 1: If the operator has deployed VoLTE on 4G and selected the SA architecture in the early stage of NR deployment, the operator can choose EPS FB as the transition solution, and the voice user will fall back to 4G. When NR is continuously covered, VoNR will be available to 5G users through software upgrade support.
- Path 2: If the operator has deployed VoLTE on 4G and selected the NSA architecture in the initial stage of NR deployment, the operator can choose 4G VoLTE to continue to provide voice services for 5G users. When NR is continuously covered, the VoNR service is provided for the 5G users through the deployment of the SA.

- Path 3: If the operator has not deployed VoLTE in 4G and selected the NSA architecture in the early stage of NR deployment, the operator can choose 4G CSFB to continue to provide voice services for 5G users. However, if the operator has not deployed VoLTE in 4G and prioritized the SA architecture in the initial stage of NR deployment, the operator can only choose the EPS FB plus CSFB solution, and then fall back from 5G to 4G and continue to fall back to 2/3G. The access delay will be longer than the EPS FB. In this scenario, IMS still needs to be deployed because EPS FB requires 5QI5 (control plane). Finally, when the NR is continuously covered, the VoNR service is provided to the 5G user by providing 5QI1 (user plane).

The 5G voice solution is based on the evolution and enhancement of existing 4G voice solutions. For the NSA architecture, the 5G voice solution remains consistent with 4G. For the SA architecture, EPS FB and VoNR are two key solutions.

The EPS FB solution establishes a default bearer for 5QI5 on the NR and falls back to 4G when establishing a dedicated bearer for 5QI1. Since 5QI5 is to be established on the NR, the EPS FB requires IMS support. In terms of voice quality, the voice quality of the EPS FB solution is consistent with that of VoLTE. Currently, most VoLTE uses AMR-WB as the default voice. In terms of access delay, EPS FB has a more fallback process than VoNR, and the overall access delay is increased by 1~2 seconds compared with VoNR. In addition, during the fallback process, the data service will also fall back to 4G, so the data service experience will be affected.

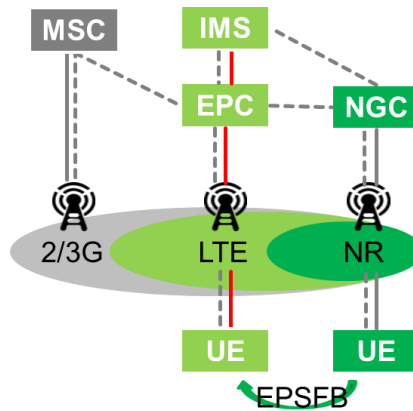

The VoNR solution is that the 5QI5 default bearer and the 5QI1 dedicated bearer are all established on the NR. It is recommended that VoNR provide EVS voice by default, and the voice quality MOS score can be increased by up to 0.5 based on the existing 4G AMR-WB. The VoNR access delay is basically the same as the existing VoLTE, which is better than the EPS FB. In addition, the VoNR solution will not cause the data service to fall back to 4G, which will ensure that the data service experience is not affected.

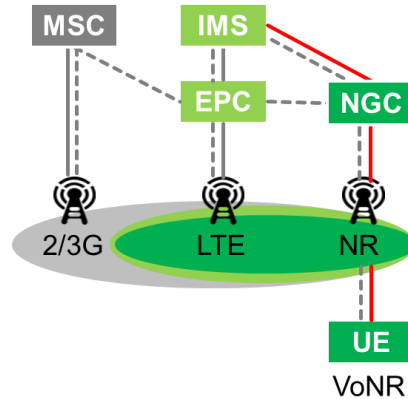

There are a few things to note when deploying a 5G voice solution:

- Unlike 4G CSFB, 5G EPS FB requires IMS support, which is for the smooth evolution to VoNR in the future.
- UEs that only support EPS FB in the initial phase of SA need to consider future smooth upgrades to VoNR. It is recommended that the UE can support both EPS FB and VoNR, so that when the network supports VoNR, the UE can quickly upgrade to support VoNR. A similar situation has occurred in 4G networks. When the network supports VoLTE, a certain percentage of UEs does not support VoLTE and select CSFB, which causes the number of VoLTE users to rise slowly.
- The EVS codec SWB mode should be the default codec for future VoNR. According to the simulation, EVS can provide the best voice quality better than AMR-NB, AMR-WB and even OPUS (OTT). This will be the advantage of 5G voice in the future competition.

5.5 Low Latency Solution for eMBB

Short delay is a key feature of 5G differentiation. A short-latency mobile network not only makes the traditional eMBB service experience better, but also drives more new services. The 5G system has a variety of advanced technologies to support NR RAN low latency. These technologies include: flexible TTI length, multiple delay service co-air ports, uplink scheduling delay, HARQ timing, and spectrum for latency services.

In the air interface, the TTI length and delay are closely related. The traditional system TTI and frame structure are bound, which affects the air interface delay. 5G design concept TTI and frame structure decoupling, native enable Non-slot. Non-slot allows the scheduled TTI to be shortened from the slot level to the symbol level, and supports scheduling of any symbol in a slot. This can bring two benefits:

- 1) TTI shortening and reducing air interface TTI processing. For the receiving end, the current packet can be received earlier, and processing starts earlier, thereby saving time delay. As shown in case 2 below.
- 2) Arbitrary symbol start scheduling in the slot, reducing the TTI boundary waiting delay. As

shown in case 3 of the figure below, the data arrives without waiting for the slot boundary. Realize the arrival and processing, and save the waiting time of the TTI boundary of the transmitting end. The scenario requires the UE to have the capability of detecting the PDCCH for each symbol, and the terminal with the capability can obtain more revenues of 5G low delay.

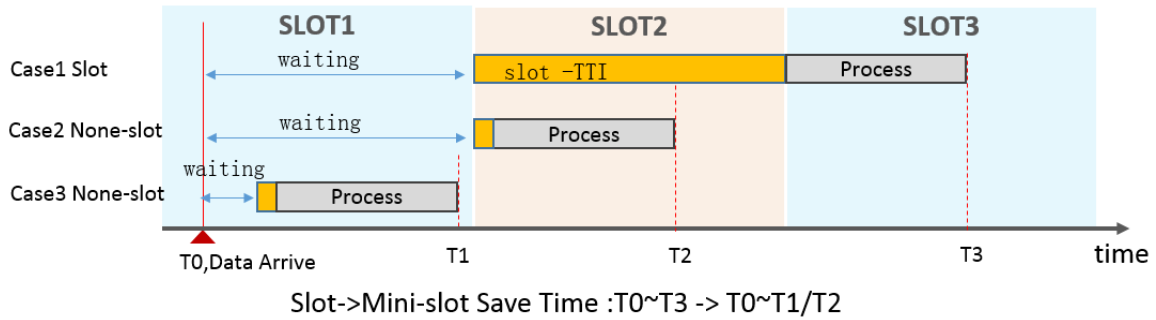

In addition, the None-slot allows the TTI length to be flexible. The time domain resource of the TTI is indicated in each scheduling grant DCI, allowing the MAC layer to dynamically adjust the length of the TTI dynamically. The flexible and variable TTI technology allows the 5G air interface to adapt to changes in eMBB traffic to achieve optimal delay. At the same time, channel condition fluctuations can also be adapted to switch only TTIs with more symbols during deep fading to provide better coverage performance.

5G's unique EAI technology supports short-latency eMBB and ordinary eMBB service co-existence. Due to the delay requirement, the short-latency service has a shorter delay from the preparation to the air interface and a longer time for the ordinary service. If the downlink air interface resources are occupied by the ordinary eMBB service, the short-latency service that arrives later cannot be sent since of air interface shortage.

By reserving air interface resource for short-latency services, you can avoid the above problems, but it will bring waste of air interface resources. The EAI air interface allows the concurrency and coexistence of multiple services through resource preemption. The Rel-15 protocol defines whether the user's downlink data transmission can be preempted by the DCI Pre-emption Indicator. With the ability to preempt the UE, the downlink service is less affected by the preemption. Users in the cell can share resource reuse and latency gains.

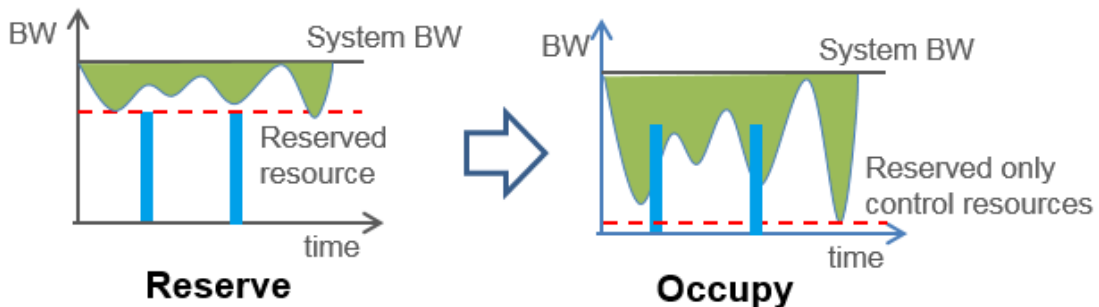

The uplink UL grant-free technology reduces the uplink delay by avoiding the uplink data transmission scheduling process.

In the uplink data transmission, the traditional scheme requires an uplink scheduling process. The UE first sends an SR to the network side, and the network feeds back the DCI to the UE based on the SR to carry the UL Grant, and the UE sends the uplink data based on the UL Grant. The overall efficiency is low.

The UL GRANT-FREE technology allows the UE to directly transmit PUSCH data at a specified cycle time based on pre-assigned uplink grant resources without an uplink scheduling process. While reducing the delay, the downlink control channel overhead is also reduced.

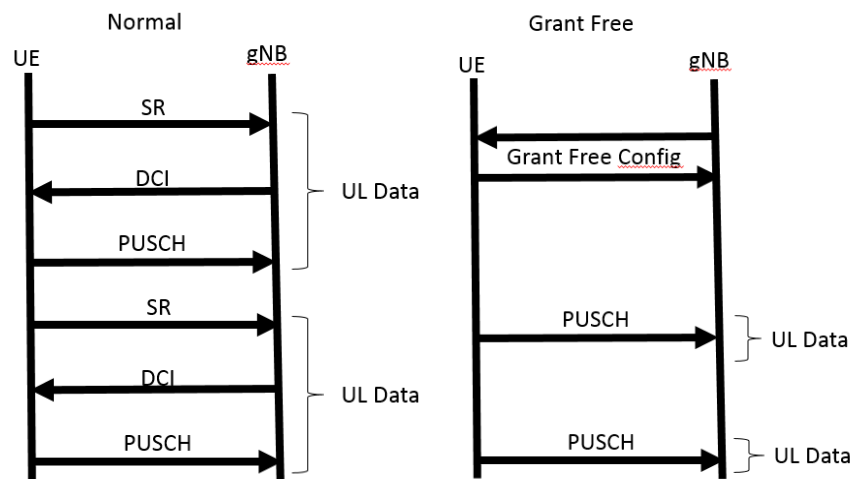

5G supports shorter HARQ timing, which reduces retransmission delay.

HARQ Timing includes both uplink and downlink. The downlink HARQ timing is defined as the time from the PDSCH to the HARQ ACK/NACK feedback, and the uplink HARQ timing is the time from the PDCCH (UL DCI) to the PUSCH. The Rel-15 protocol defines two UE HARQ timing capabilities and varies according to different subcarrier widths. The Capability1 UE can support HARQ timing N+1 in extreme scenarios. The Capability 2 UE has shorter HARQ timing processing capabilities, allowing support to be as small as N+0.

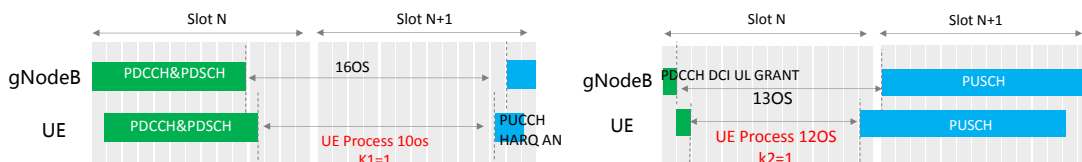

HARQ timing defines the processing delay requirements of the MAC layer. However, for the user, the experience is PDCP and upper latency. In general, UE devices with lower HARQ timing can also provide lower PDCP -> air interface delay. This is a necessary condition for

achieving a real short delay in the user interface. The relationship between HARQ timing and PDCP->air port delay is shown in the figure below. The following line delay is taken as an example, and the uplink delay is the same.

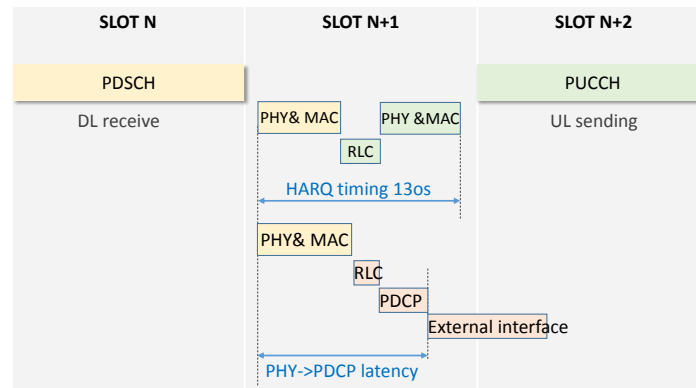

The 5G network has a diversified spectrum and supports different levels of low-latency services in different frequency bands. The mid-band supports low latency and large packet counts. Mid-band benefits from large bandwidth and multiple antennas can send larger packets per slot. Subject to the TDD system, the air interface does not have a U frame every moment, which additionally brings an uplink waiting delay. For example, in a 4:1 ratio, wait up to 4 slots; in an 8:2 ratio, wait up to 8 slots. SUL can be used as a supplement to the mid-band to make up for the shortcomings of the TDD system waiting for the uplink slot cycle. High frequencies can support low latency and large flows. The high frequency subcarrier is wider, the slot is shorter, and the uplink and downlink switching period of the TDD is short, and a lower delay can be achieved. FDD is suitable for small packages and ultra-low latency services. FDD NR does not have uplink and downlink handover waiting to achieve a lower air interface delay. Limited by the bandwidth of FDD, FDD is suitable for smaller packets to achieve ultra-low latency.

6 Network Deployment Strategy

6.1 Service Selection and Requirements

Main 5G services include eMBB, mMTC, and URLLC. However, the main services are eMBB services in the current stage. Typical eMBB services are as follows:

- HD video
 - 5G can provide larger capacity, such as HD surveillance and 4K/8K movies. The requirement for the downlink rate is greater than 50 Mbps.
- VR/AR
 - VR/AR is not only entertainment, but also applies to business (live broadcast), education

(VR teaching), and medical care. The requirement for the downlink rate is greater than 100 Mbps and the latency is less than 20 ms.

- Networked UAV

5G can meet the requirements of low altitude coverage and high bandwidth required for long-distance flight of unmanned aerial vehicles (UAVs). The requirement for the uplink rate is greater than 50 Mbps and the latency is less than 50 milliseconds.

At the early stage of 5G deployment, to ensure basic service experience, the downlink rate must be at least 50-100 Mbps, the uplink rate must be 3-5 Mbps and the latency be less than 20 ms.

6.2 5G Networking Suggestions

In the initial deployment phase of 5G, the following aspects must be considered in networking:

- Coverage

For the 2.6 GHz and 3.5 GHz eMBB, although the frequency bands are higher than those for traditional 4G, the multi-antenna technology can be used to supplement the coverage. Therefore, it is recommended that 5G and existing 4G networks be constructed in 1:1 mode to ensure continuous coverage in the initial deployment area and reduce planning and optimization costs. 4.9 GHz or mmWave can be deployed for local hotspots to increase the capacity.

- Spectrum

Because the uplink and downlink timeslot ratios of New Radio (NR) are not balanced and the downlink power of the gNodeB is large, the uplink and downlink coverage of 5G is unbalanced. As a result, the uplink coverage is limited. In addition, with the introduction of technologies such as beamforming and cell-specific reference signal (CRS)-free, downlink interference decreases, and 5G uplink and downlink coverage gaps increase. Based on the preceding reasons, a new spectrum pairing mode is defined for uplink and downlink decoupling. In the uplink restricted area, downlink data is transmitted in high frequency (for example, C-band/4.9 GHz/mmWave), and uplink data is transmitted in sub-3 GHz (for example, 1.8 GHz), thereby improving uplink coverage. For instance, compared with C-band, SUL PUSCH improves uplink coverage by 10 dB.

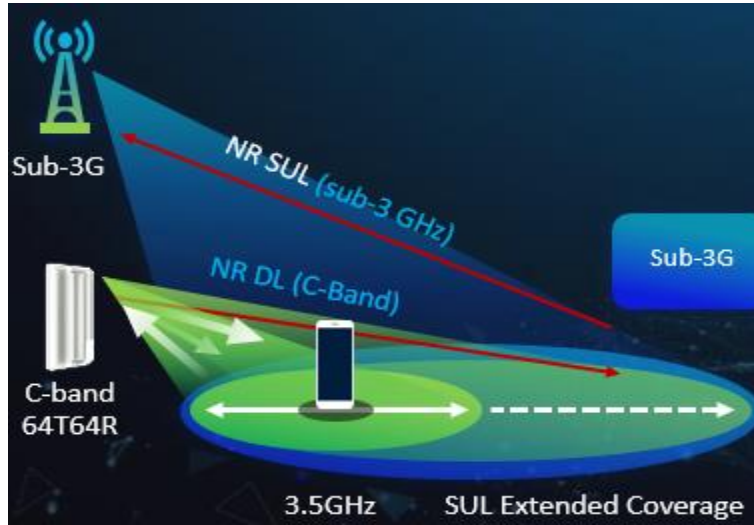

■ Site type selection

Compared with 16T/32T, the multi-user pairing gain of 64T can provide a larger capacity. The multi-antenna link gain of 64T can provide more intensive coverage, including high-building coverage.

Therefore, despite higher single site cost, 64T is the best in terms of total cost thanks to significant site count reduction. It is recommended that 64T be deployed to reduce the TCO.

To Cover Same Area	64T	32T	16T
Required site number	1	1.18X	1.48X
CAPEX (Equipment, transmission, power, etc.)	1	0.95X	1.11X
OPEX (electricity, rental, O&M, and transmission)	1	1.55X	2.83X
Deployment suggestion	Urban	Urban	Suburban/Rural

Considering the better capacity and coverage of 64T, it is recommended that 64T be deployed in urban areas with high capacity and deep coverage requirements, and suburban areas with strong coverage requirements.

■ Subframe configuration

In NR-LTE intra-frequency or adjacent-channel networking scenarios, the NR-LTE uplink and downlink frame structures must be aligned to avoid co-channel interference.

7 Large-Scale Pre-commercial Trial Result Sharing

As a continuous effort to prompt global wireless ecosystem, GTI has set a plan for the roadmap of 5G PoC and trial and commercialization (as shown in Figure 7-1), and published the white paper of PoC in 2017.

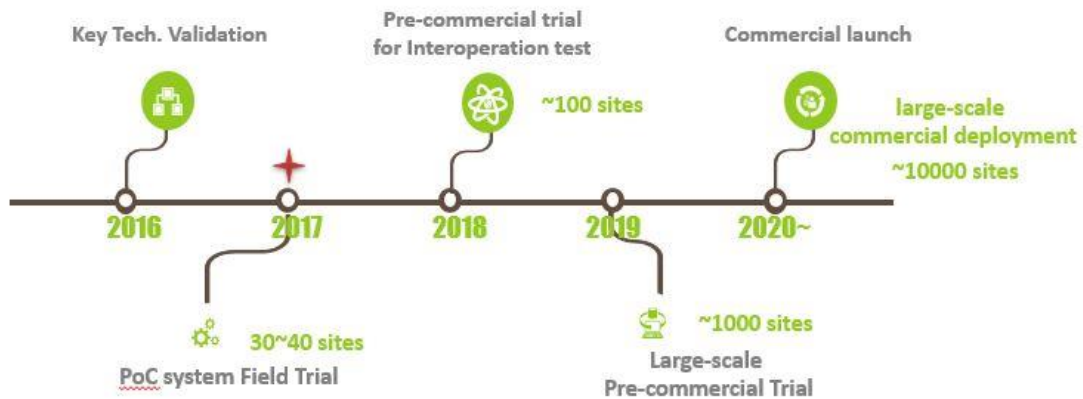

Figure 7-1 Timeline for 5G PoC and Trial and Commercialization of GTI

In term of the pre-commercial trial in 2018, there are many new capabilities and performance requirements. With the benefit of 5G technology and solutions that have been introduced in this white paper, we already have exciting results in the real pre-commercial trial environment. It is pleased to share some of the results with industrial partners and accelerate the global momentum to make 5G into reality!

7.1 5G Pre-commercial Trial in Hangzhou

7.1.1 Overview of Trial in Hangzhou

Starting from Feb. 2018, China Mobile and Huawei together launched the "5G City" plan and began to deploy 5G pre-commercial network in Hangzhou, China. According to the plan, 100 5G sites will be deployed in July and 300 5G sites in Oct, with the coverage of 100 square kilometers. Up to now, with Huawei 5G end-to-end products and solutions, more than 300 5G NR sites have been constructed at 3.5 GHz across Hangzhou major urban areas and typical scenarios including Hangzhou Wulin Commercial Circle, Qianjiang New City, West Lake Scenic Area, Zhejiang University, Dream Town and others. This pre-commercial 5G network test area is served for scale technology test, 5G agile research and development, application innovation incubation and business promotions.

7.1.2 Network Deployment and Architecture

The network chose NSA network architecture and adopts 64T64R Massive MIMO to achieve a continuous Gbps-level rate experience across the area. The test results show that single-user peak rate is 2.5 Gbps, which enables a 16-channel 4K HD video synchronous playback. It is expected that it will achieve 20 Gbps peak rate utilizing sufficient mmWave spectrum in the future.

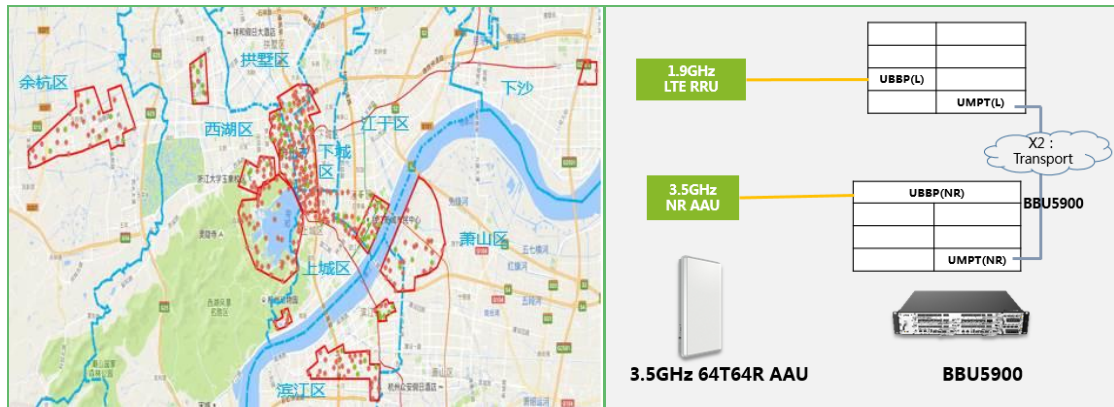

Figure 7-2 Pre-Commercial trial network in Hangzhou

7.1.3 Trial Results of Performance

1. High Capacity with Massive MIMO

Taking the 5G boutique network of Hangzhou Qianjiang New City as an example, with 100 MHz continuous spectrum at 3.5GHz, Huawei 64T64R Massive MIMO solution is deployed at the original LTE sites, with the station distance of about 420 meters. A drive test shows that the cell capacity and coverage are significantly improved: 95% of the 5G NR covered area achieved better signals than -85 dBm, the average downlink peak data rate of a single user reached 2.5 Gbps, which is 25 times higher than that of current LTE live network; the downlink average rate of a single user reached 1.1 Gbps, 25 times that of the LTE live network.

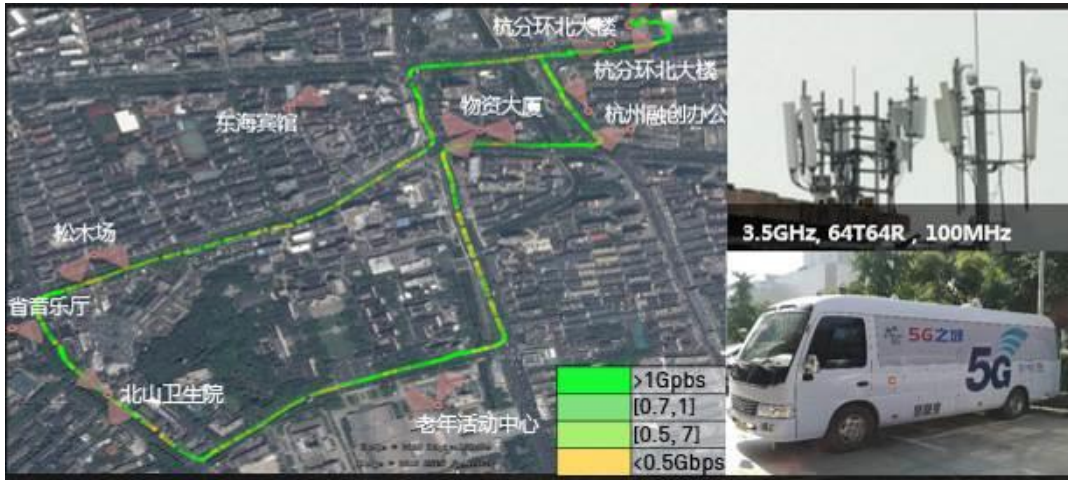

Figure 7-3 Drive test of M-MIMO capacity

2. Coverage Enhancement with SUL

At the same time, enabled by Huawei 5G SUL solution, the downlink capability of C-band has been released and the uplink coverage bottleneck has been eliminated, the test shows that the capacity and coverage have been enhanced by 2-6 times at C-band, achieving the same coverage with 1.8 GHz. (as shown in Figure 7-4)

SUL Enable Indoor UL Rate Increase 2-6 times

SUL Enable Indoor DL Increase 20%~200%

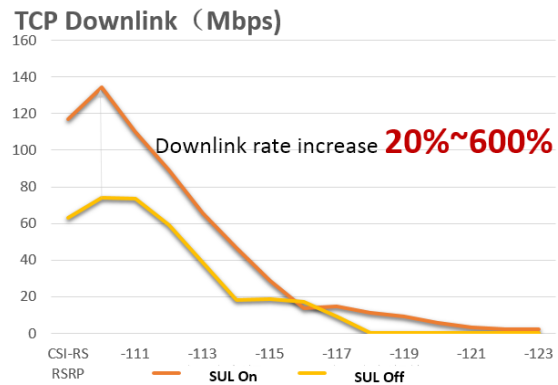
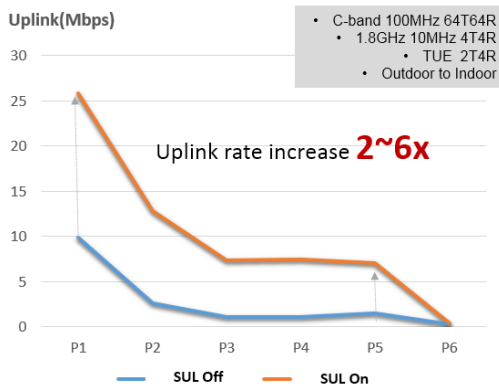

Figure 7-4 Coverage test with SUL On/Off

7.1.4 Validation of Easy Deployment

During the deployment, with its commercialization-oriented compact shape and engineering capability, Huawei Massive MIMO products suite and 1+1 Simplified Antenna Solution can adapt to a variety of installation scenarios (as shown in 错误!未找到引用源。), including poles on rooftops (~70% of the deployment scenarios), Poles on roadside (~10%), the Tube tower

(~20%), and the parapet wall.



Figure 7-5 Deployment scenarios of M-MIMO in Hangzhou

7.1.5 Trial Cases of 5G New Services

With the high capacity and high coverage of the network, various 5G-only services and applications can be carried out. China Mobile and Huawei demonstrated multiple application scenarios such as AR maintenance, VR live broadcast of West Lake Sceneries, wireless drones, remote media treatment and holography communication.



Figure 7-6 5G new Services in Hangzhou

7.2 5G Pre-commercial Trial in Guangzhou

7.2.1 Overview of Trial in Guangzhou

According to the trial timeline of GTI, in the phase of 5G pre-commercial trial, ZTE and China Mobile plan to construct 100 pre-commercial sites in February 2019 and conduct multi-vendor end-to-end performance verification from 2018 to 2019.

In 2018, ZTE and China Mobile planned introducing a comprehensive 5G key technology and end-to-end verification in Guangzhou. The verification needs to include CBD, commercial

complex, dense residential area, entrepreneurial park, college campus, urban expressway, etc. Due to the requirements of rich verification scenarios and being closer to real commercial networks, the scale of the trial network needs more than 100 sites.

To fulfill the 2018 5G verification target, ZTE and China Mobile finally selected the Wanbo Business District, Guangzhou Automobile Park, Zhujiang New City, Pazhou Convention and Exhibition Center, China Mobile Southern Base and Guangzhou University City. Among them, Zhujiang New City contains scenarios of CBD and commercial complex, which is a typical dense urban scenario and also the main verification area.

7.2.2 Network Deployment and Architecture

In November 2018, China Mobile obtains 2.6 GHz and 4.9 GHz frequency bands as the test frequency bands for 5G technology research and development. The Guangzhou 5G field test will mainly select 2.6 GHz for networking and testing, and also conduct 4.9 GHz testing in the University City.

The site deployment is BBU+AAU mode, IT BBU supports all six modes, 2U height, 19 inch wide, multiple installation modes, SA/NSA networking, large capacity, multiple transmission interfaces, and various synchronization methods, supports CU/DU integration or split.

The AAU meets the requirements of all mainstream 5G frequency bands: 2.6 GHz, 3.5 GHz, and 4.9 GHz. The AAU has high integration, small windward area, convenience for installation, 24-layer transmission, eCPRI interface, and one 25G optical fiber to meet transmission requirements.



Figure 7-7 5G BBU and AAU in Guangzhou

7.2.3 Trial Results of Performance

1. Real-Time Peak Rate & Latency Test

The 5G data rate test was carried out on the Pearl River, about 10 meters away from the 5G site. The test is mainly divided into two parts: peak rate and delay. The test CPE supports 2T4R and connects to 5G base station via 5G new air interface. Computer shows that the real-time peak rate can be achieved above 1.5Gbps@100 MHz 4 streams,

showing the large bandwidth of 5G NR. The delay is tested by ping packets and user plane delay is less than 8 ms, showing the ultra-low latency of 5G NR.

2. Mobility Test

In addition, ZTE also completed mobility test in Zhujiang New City field. Surrounding Huaxun Street, a vehicle equipped TUE keeps the connection with 5G base station during the test.



Figure 7-8 Mobility test

7.2.4 Trial Cases of 5G New Services

At the China Mobile Partner Conference held in Guangzhou in December 2018, China Mobile and ZTE Corporation displayed a large number of new 5G services. Partner with China Mobile, ZTE showed 5G 8K and 4K panoramic HD live broadcast, industrial AR robot arm, 5G experience car, etc. All test fields in Guangzhou's field were unveiled.

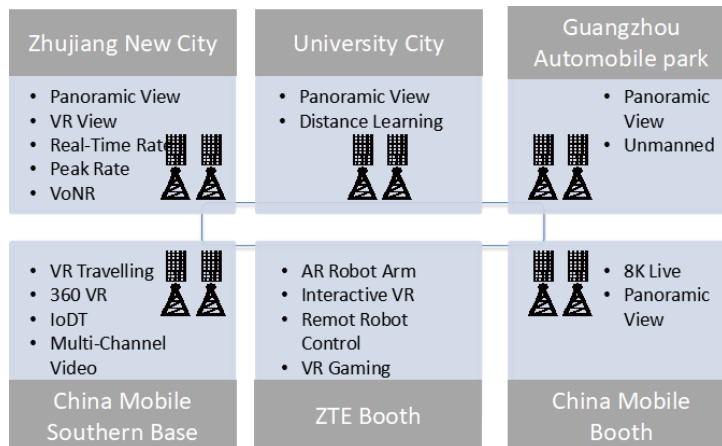

Figure 7-9 Major 5G Trial cases in Guangzhou

7.3 5G Pre-commercial Trial in Suzhou

7.3.1 Overview of Trial in Suzhou

Ericsson is selected to deploy 5G sites including SA and NSA mode in Suzhou. According to plan, about 100 sites will be deployed, covering about 21 km² in total. All required SA and NSA test cases will be tested according to CMCC arrangement. NSA mode test cases can be done before end of Nov 2018 and SA mode test cases can be done before the end of Dec 2018.

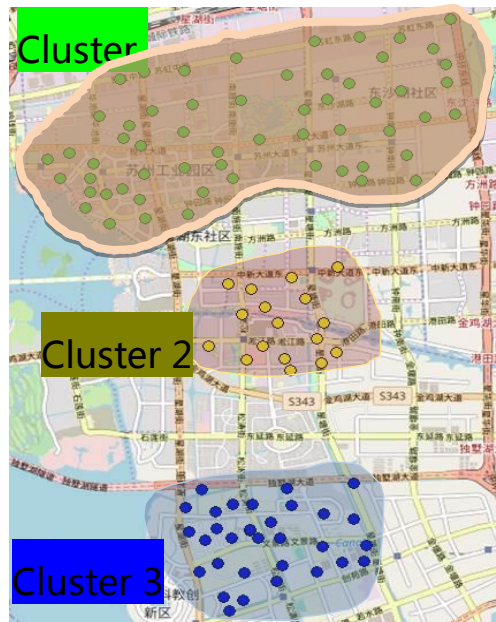

Figure 7-10 Trial Cluster in Suzhou

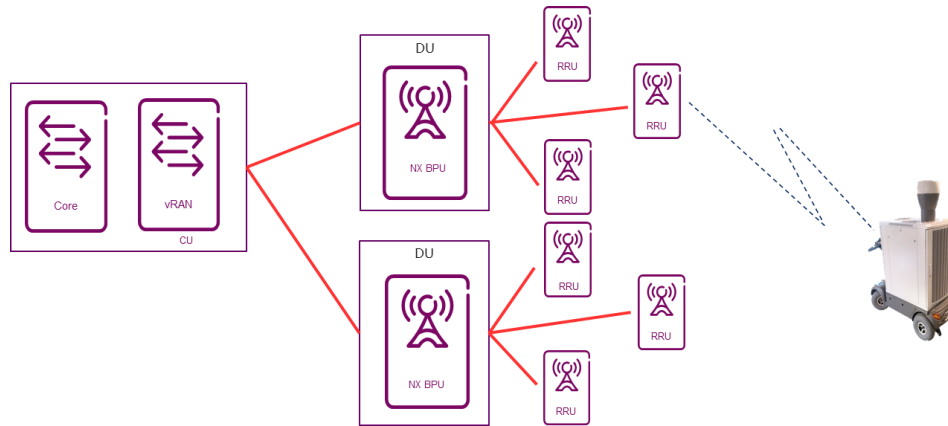

Figure 7-11 Architecture of Trial network in Suzhou

7.3.2 Multiband Propagation Capability

A frequency scanner is used to get the path loss for different frequencies. The basic trend is higher path loss with higher frequency.

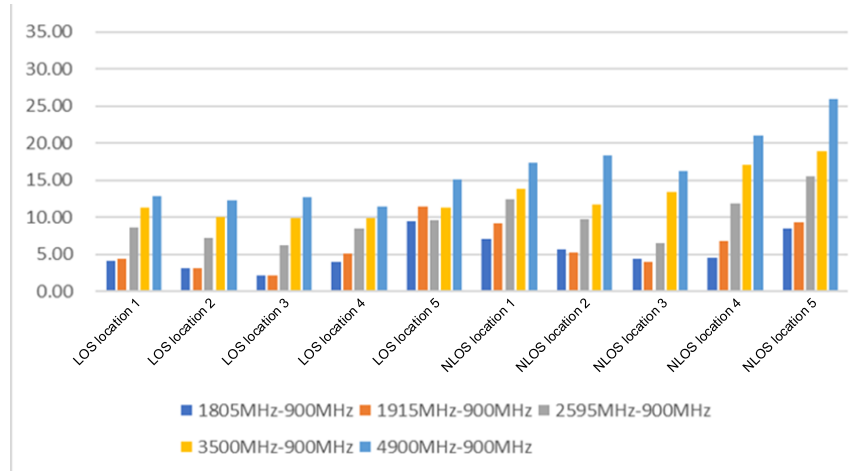

Figure 7-12 Path loss compared with 900 MHz

7.3.3 1/4 SSB Coverage Comparison

According to test result, 4 SSB has better coverage compared with 1 SSB.

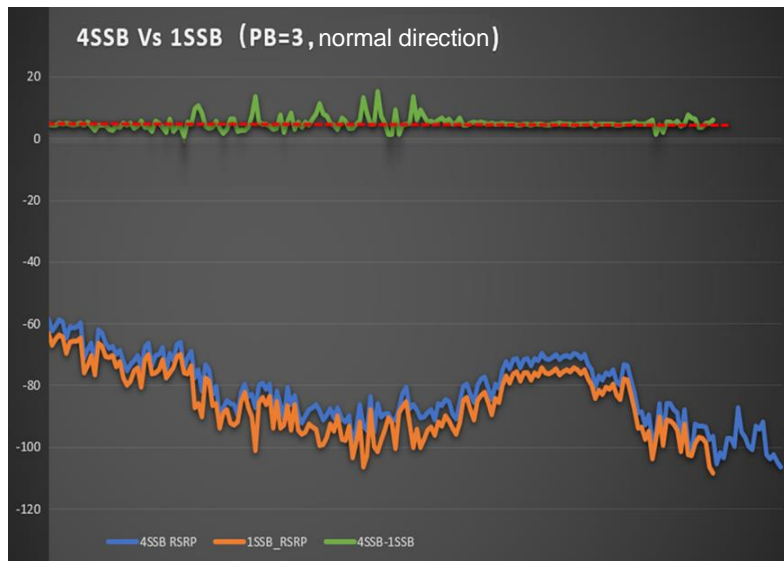

Figure 7-13 1 SSB vs 4 SSB for coverage

7.4 5G Pre-commercial Trial in Shanghai

7.4.1 Overview of Trial in Shanghai

In 2018, Nokia and China Mobile carried out a comprehensive 5G NSA trial in Shanghai. Two trial networks were built in urban areas in Shanghai. The largest one includes 25 NSA macro sites, and the NR site types used for the field trial include macro site, street site, micro site and indoor solutions. The key NR network technology such as capacity, coverage, mobility, and network architecture were verified. The average single-UE throughput of 1 Gbps was reached during the test. Nokia also trialled NR micro cells in the field. The field trial well supports NR commercial deployment in next step.

7.4.2 Network Deployment and Architecture

NR performance and typical 5G applications were tested based on NR cloud RAN and edge cloud deployment in CMCC Shanghai NR trial networks.

As shown in figure 1, the DU was deployed near to 5G RRU and the CU was deployed with the edge cloud platform in an aggregation transport equipment room, where is approximately 2 km from the DU equipment. Two application servers were deployed to test the 5G application. One is an edge app server which is deployed in the edge cloud platform and connects with the CU through a gateway, and the other is a remote app server, which is a server in Internet and connects with 5G system through the central cloud.

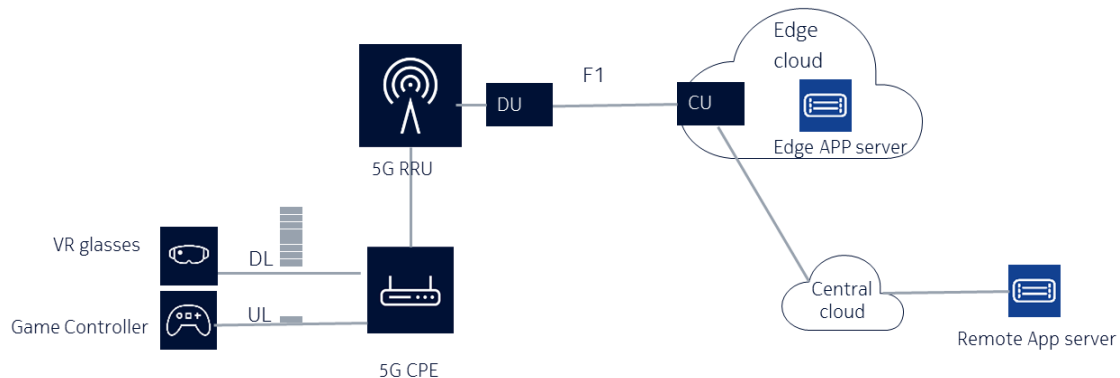

Figure 7-14 NR Cloud RAN and edge cloud test

The Nokia products and solution for the 5G Cloud RAN were used in the test. The solution includes products for the cloud and infrastructure management, and for the management of the radio network elements. Also, the data center (DC) hardware and virtualized infrastructure are offered for the actual radio network VNFs for 4G and 5G base stations.

The cloud management products implement the management of reference points defined in ETSI standards, while the AirFrame DC hardware and NCIR infrastructure layer are tailored

to ensure lowest total cost of ownership for the Cloud RAN Solution.

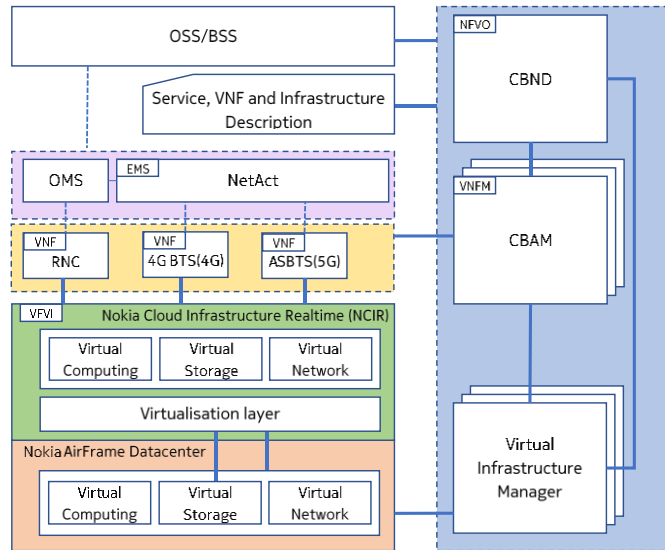

Figure 7-15 Cloud RAN platform in ETSI NFV

7.4.3 Trial Results of CU/DU Splitting and Edge Cloud

Cloud VR services are among the most demanding 5G native applications, where extreme low latency and high bandwidth are required. In the test, we use an example of VR cloud gaming where user-specific 3D game video is rendered in the Edge App server and Remote App server, respectively.

Cloud VR services are among the most demanding ones
 ...and flawless user experience is a must



Service requirements

- High, instant and constant video bandwidth
- Low round-trip time (<10ms)
- Tight synchronization (tolerate no jitter)

Figure 7-16 Cloud VR game in the test and QoE requirements

In the test, NR performance was compared between gNodeB with CU/DU splitting (cloud RAN) and reference case that gNodeB with CU/DU collocated. Round Trip delay of gNodeB

with CU/DU splitting is 7 ms which is almost same as gNodeB with CU/DU collocated. The reason is the distance between CU and DU is not far in the test. In practice, RTT between CU and DU can reach 10 ms at the maximum, which responds to the transport distance of about 500 km. With longer distance between CU and DU, the latency of gNodeB, which treat as UE PDCP to CU PDCP, should be increased. But from application point of view, such gNodeB latency increase has little impact on services, as end-to-end latency of services is dominated by application server location that is near/far from the terminals. For RTT between UE and App server, it is 11 ms and 36 ms for edge App server and remote App server, respectively. It means that application deployment in edge cloud can greatly reduce the application latency and be helpful for 5G to provide new services.

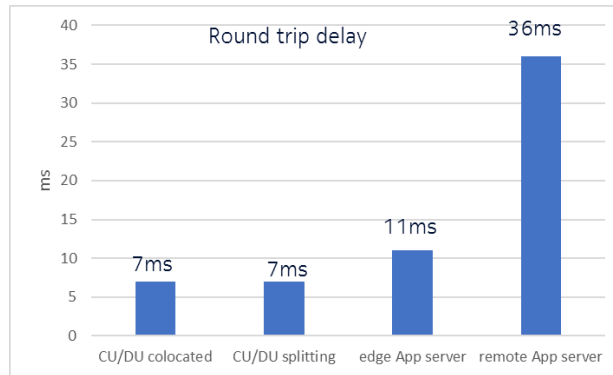

Figure 7-17 Round trip delay of gNodeB and App server

The QoE of Cloud VR game was evaluated according to VR game streaming quality, cybersickness, presence and jitter. High score means good user experience. When VR game is deployed in edge app server, the QoE score is 99% which means very good user experience. When VR game is deployed in remote app server, the QoE score is 32% which means poor user experience. As the VR game services are highly interactive, if content for the head-mounted display is not delivered fast enough, users may experience loss of synchronization between what they feel (with body motion, head orientation) and what they see. This will result in poor or negative user experience.

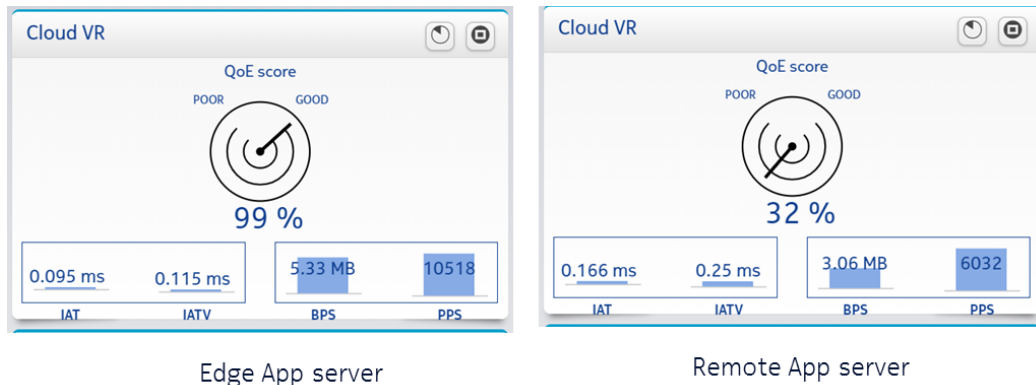

Figure 7-18 QoE of Cloud VR for edge cloud solution and Remote

App server solution

The test shows that 5G cloud RAN is ready for commercial rollouts. The benefits are as follows:

- Network functions on standard IT hardware
- Automated network function deployment
- Network function scalability and fast end-to-end service creation

Cloud RAN enables CSPs to reduce the network CAPEX and OPEX via integrating with functions/applications in the edge cloud platform, for example, UPF, edge application, and AI enabling new services in 5G.

Besides that, the network edge cloud will play a critical role to better manage the rich media applications.

First, if we just perform streaming services, caching content close to the network edge will save backhaul network resources. In some cases, for example, at the launch of a new episode of a popular series, this may have significant effect.

Then as we'd like to enable latency sensitive interaction-rich applications, such as 3D VR or AR experience, we will also place live visual content creation close to the end devices, to save the critical milliseconds on end-to-end delivery and drastically improve the response time.

Finally, to optimize service experience and radio resource usage in real time, we must access traffic streams in the edge for our real-time cognitive functions.

7.5 5G Pre-commercial Trial in Wuhan

7.5.1 Overview of Trial in Wuhan

In December 2017, CMCC and CICT launched the construction of 5G scale trial network in Wuhan. By 2019, more than 100 sets of 2.6GHz base stations have been built which cover an area of 20km² including dense urban areas, urban district, scenic spots. In the trial, end-to-end test with commercial terminals was executed, providing basic reference data for network planning, construction and operation.



Figure 7-19 Base station construction area

7.5.2 Network Deployment and Architecture

23 NSA base stations and 100 SA base stations were deployed with CICT's large-capacity compact BBU and AAU. The trial area was covered continuously, providing 1Gbits service experience at anytime and anywhere which is more than 20 times the 4G network throughout. The trial network supports NSA/SA dual mode configuration. In the early stage, it's suggested to install CU and DU at the same place to reuse the existing network architecture. CU and DU setting up separately is also supported, in order to fulfill the radio cloud.

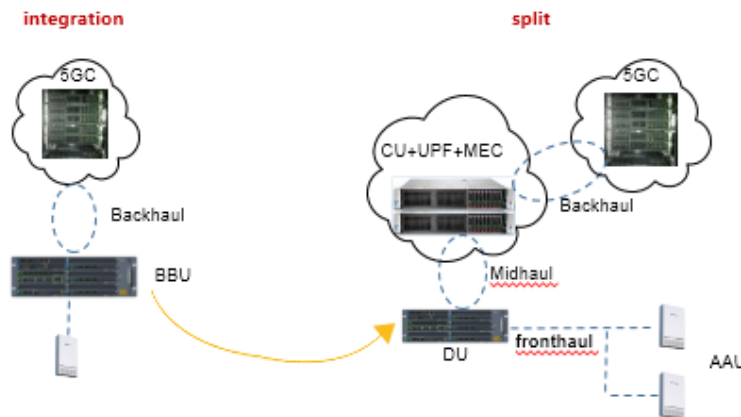

Figure 7-20 Network Deployment and Architecture

7.5.3 Trial Results of Performance

1、NSA with LTE TDD as an anchor

The trial constructed NSA network with LTE TDD as an anchor. TUE, terminal chips did test in the network. The test result shows the NR with LTE TDD as an anchor can provide a shallow coverage with outdoor base stations, providing the continuous network coverage.

With the signal decreasing, RI, MCS and PDCP throughput decreases gradually. When RSRP reaches -123.8dB, UE drops off. Uplink MCS and PDCP throughput decreases when the signal becomes weak. Throughput decreases to zero when RSRP is -126.5dB at the edge of the cell. The overall trend meets expectations.

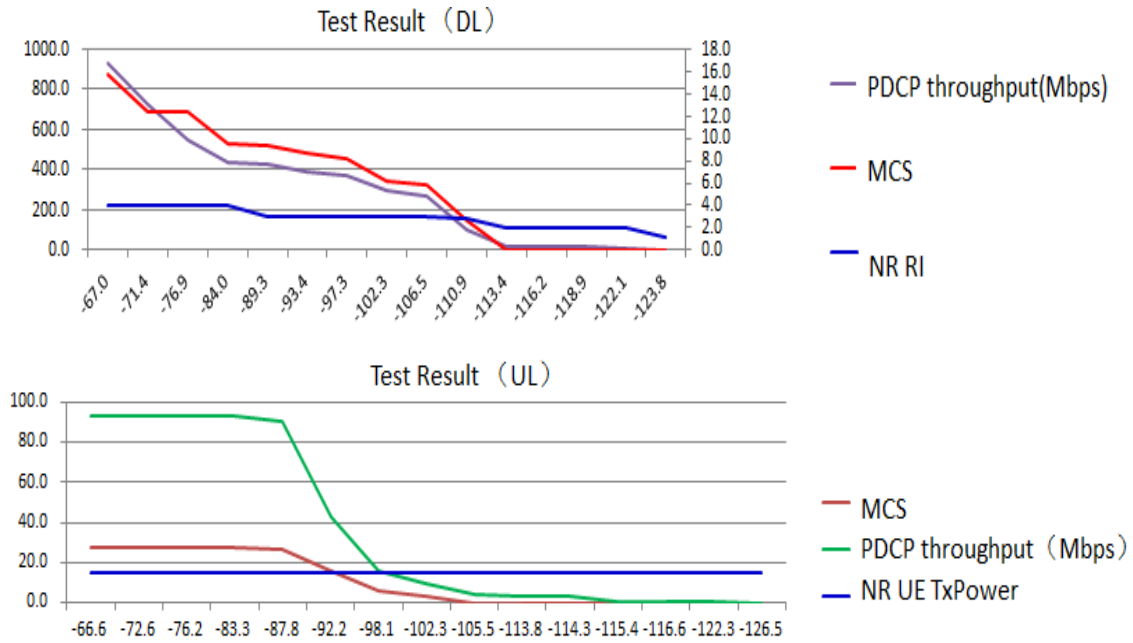

Figure 7-21 DL & UL Test Results in NSA with TDD LTE Anchor

2、DAS Indoor Test

DAS indoor test in CICT’s office buildings and factory scenes, which is around 7000m2. We re-use existing 4G DAS to deploy and verify 5G DAS. In this scenario, existing 4G DAS is a single-channel system. The total number of equipment used is 1 BBU, 2 RRUs, 370 meters cable, 2 combiners and 38 passive components.

We have adopted three deployment scheme.

On the left side of 1F, we use Dual-channel distribution system with single-polarized antenna. In same location, there is also another single-polarized antenna form Dual-channel system for test. On the right side of 1F, we test dual-channel system with dual-polarized antenna which is different form Dual-channel distribution system.

Single user peak data rate has been tested In this trial. Test Terminal is 2T4R device, 4 stream for downlink and 1 stream for uplink (when mode is NSA) can be reached when single UE are adopted. Peak Rate of DL can reach 700~750Mbps when using Dual – Channel DAS. And almost 350Mbps when using Single – Channel DAS. Theoretical peak data has been reached.

UE needs to keep a channel connected to 4G when using NSA mode. So single-user can only get single stream on UL path no matter what system deployment mode it is. As the results shows, it can be reached around 90Mbps.

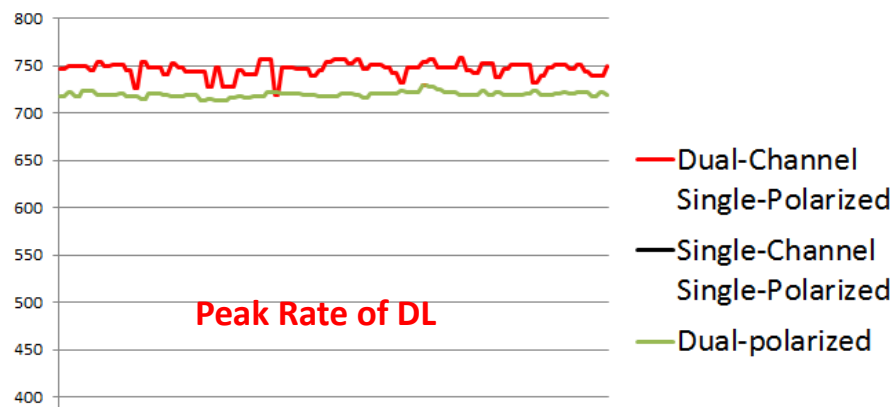

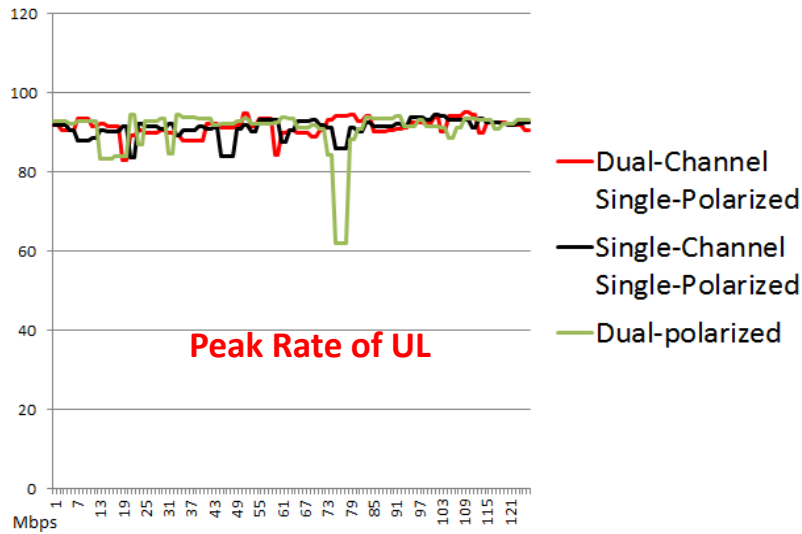

Figure 7-22 DAS Indoor Test Results

7.5.4 Trial Cases of 5G New Services

CMCC, CICT and the leading enterprises strive to promote the integration of vertical industry, such as smart navigation, smart grid and smart factory and so on.

Smart navigation is a typical use case of operator provided enterprise network. A 5G-based Yangtze River broadband mobile communication system was built. The use of 5G can provide more capabilities in maritime supervision and law enforcement, channel management and maintenance, navigation supervision, shipping information services and etc.

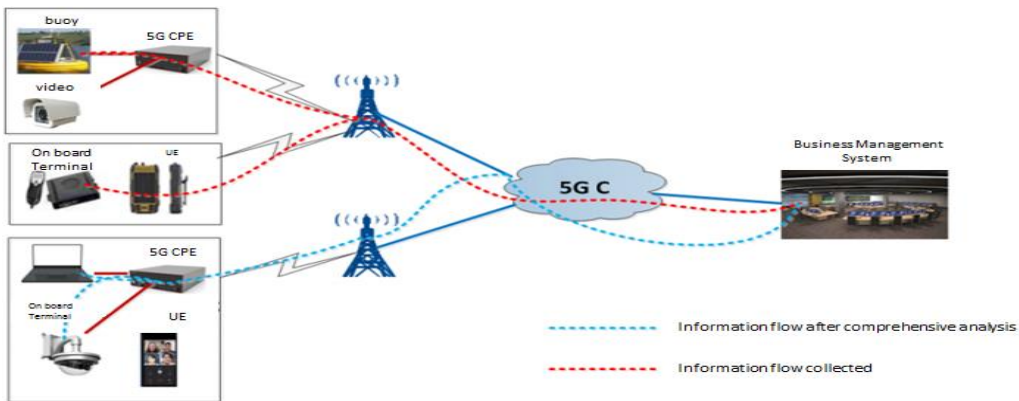

Figure 7-23 Smart navigation network scheme

Intelligent factory is a typical case of enterprise informatization. 5G intelligent factory based on 5G network, can make the overall production efficiency increase by 15%

8 Summary

GTI sub-6 GHz 5G Pre-commercial Trial Whitepaper targets eMBB scenarios for sub-6 GHz. This document is conducted to be the technical and solution references for 5G pre-commercial trial deployment. Addresses the key aspects of Architecture, Solutions and Deployment strategy for pre-commercial trial, and sharing the experience and key findings in the real trial cases.

According to the progress of 3GPP 5G NR standardization and the findings from the trials, there will be some issues that need to be discussed in the updated version of this whitepaper in the future.