

**GTI**

**5G MEC**

**White Paper**

**GTI**

<http://www.gtigroup.org>

# ***GTI 5G MEC***

## ***White Paper***



<b>Version:</b>	V1.0
<b>Deliverable Type</b>	<input type="checkbox"/> Procedural Document <input checked="" type="checkbox"/> Working Document
<b>Confidential Level</b>	<input checked="" type="checkbox"/> Open to GTI Operator Members <input checked="" type="checkbox"/> Open to GTI Partners <input type="checkbox"/> Open to Public
<b>Working Group</b>	Network Working Group
<b>Task</b>	5G eMBB Architecture - MEC
<b>Source members</b>	ZTE, Huawei, Nokia, CMCC
<b>Support members</b>	

<b>Editor</b>	ZTE, He Wentao; HUAWEI, Li Zhi; Nokia, Yang Peng; CMCC, Wu Tong
<b>Last Edit Date</b>	20-02-2019
<b>Approval Date</b>	DD-MM-2019

**Confidentiality:** This document may contain information that is confidential and access to this document is restricted to the persons listed in the Confidential Level. This document may not be used, disclosed or reproduced, in whole or in part, without the prior written authorization of GTI, and those so authorized may only use this document for the purpose consistent with the authorization. GTI disclaims any liability for the accuracy or completeness or timeliness of the information contained in this document. The information contained in this document may be subject to change without prior notice.

## Document History

Date	Meeting #	Version #	Revision Contents
DD-MM-2018		v0.1	Initial draft of GTI 5G MEC White Paper

## Table of Contents

1 Abbreviations .....	6
2 Overview .....	11
3 References.....	12
4 5G MEC Industry Progress.....	13
4.1 Introduction .....	13
4.2 Standard Progress .....	14
4.3 Business value and market demand.....	16
4.4 MEC industry chain .....	17
4.5 MEC business progress.....	19
5 MEC Target Network Architecture in 5G .....	21
5.1 5G Overall Network Architecture .....	21
5.2 5G MEC overall deployment recommendations .....	23
5.3 5G MEC development solution in 5GC.....	25
5.4 5G MEC management and orchestration solution .....	26
5.5 5G MEC Network Capability Openness .....	27
6 MEC Key Solution and Innovation .....	32
6.1 ETSI MEC reference architecture.....	32
6.2 MEC Virtualization Solution .....	37
6.3 5G MEC security solution .....	38
6.4 5G MEC hardware acceleration solution .....	40
6.5 Mobility management of edge services in 5G network .....	42

6.6 5G MEC charging solution .....	45
7 Use Case and Trial .....	47
7.1 VR Cloud Gaming.....	47
7.2 TCP Optimization base on MEC.....	48
7.3 Smart factory base on MEC.....	50
7.4 Smart hospital base on MEC .....	51
7.5 Smart port base on MEC .....	52
7.6 Smart Refinery base on MEC.....	53
8 Summary .....	54

---

## 1 Abbreviations

<b>Abbreviations</b>	<b>Description</b>
OT	Operation,Technology
IT	Information Technology
CT	Communication technology
ICT	Information and Communication Technology

MEC	Multi-access Edge Computing
MEP	Multi-access Edge Computing Platform
OTT	Over The Top
CDN	Content Delivery Network
DC	Data Center
eMBB	enhance Mobile Broadband
mMTC	massive Machine Type of Communication
uRLLC	ultra Reliable & Low Latency Communication
CAPEX	Capital Expenditure
OPEX	Operating Expense
CUPS	Control and User Plane Separation of EPC nodes
HGU	Home Gateway Unit
OLT	Optical Line Terminal
BRAS	Broadband Remote Access Server
SDN	Software Defined Network
CORD	Central Office Re-architected as a Data Center Architecture
NFV	Network Function Virtualization
NFVI	Network Functions Virtualization Infrastructure
NFVO	Network Functions Virtualization Orchestrator
VNF	Virtual network function

VNFM	VNF Manager
MANO	Management and Orchestration
DevOps	Development and Operations
UPF	User Plane Function
RNIS	Radio Network Information Service
CPE	Customer Premise Equipment
OSS	Operation support system
AMF	Access and Mobility Management Function
SMF	Session Management Function
MME	Mobility Management Entity
IoT	Internet of Things
IoV	Internet of Vehicles
NB-IoT	Narrow Band Internet of Things
CU	Central Unit
DU	Distributed Unit
SBC	Session Border Controller
BGN	Broadband Network Gateway
APP	Application
API	Application Programming Interface
IDC	Internet Data Center



COTS	Commercial Off The Shelf
BIOS	Basic Input Output System
FW	FirmWare
OS	Operating System
GPU	Graphics Processing Unit
FPGA	Field Programmable Gate Array
VIM	Virtualized Infrastructure Manager
PIM	Physical Infrastructure Manager
CMP	Cloud management platforms
MEC	Multi-access Edge Computing
MEPO	Multi-access Edge Platform Operation
MEPM	Multi-access Edge Platform Manager
RO	Resource Orchestrator
NS	Network Service
NSO	Network Service Orchestrator
LCM	Life Cycle Management
SRS	Sounding Reference Signal
RRU	Radio Remote Unit
GTP	GPRS Tunneling Protocol
AR	Augmented Reality

VR	Virtual Reality
CQI	Channel Quality Indicator
SINR	Signal to Interference plus Noise Ratio
BLER	Block Error Ratio
QoS	Quality of Service
MQTT	Message Queuing Telemetry Transport
COAP	Constrained Application Protocol
FTTP	Fiber To The Premise
FTTC	Fibre To The Cabinet
V2X	Vehicle to Everything
NAPT	Network Address Port Translation
AI	Artificial Intelligence
EVO	EDGE Video Orchestration
RSU	Road Side Unit
OBU	On Board Unit

## 2 Overview

More and more people believe that the arrival of the 5G era will have a profound impact on the evolution of the information society in the future. The in-depth integration of 5G networks with big data, artificial intelligence, virtualization and other technologies will become the key to digital transformation in various industries.

The new services under the 5G Internet of Things show the characteristics of lower latency, greater bandwidth and more intelligence. The traditional network architecture has obvious shortcomings in resource sharing, agile innovation, flexible expansion and simple operation and maintenance. In order to meet the needs of the future 5G business and enhance the competitiveness of operators in the vertical industry, the flexible deployment of multi-layer telecommunications cloud network will become the key to the transformation of 5G networks.

Multi-access edge computing technology is a key technology to support operators' 5G network transformation. By sinking applications to the edge of the network, the bandwidth pressure of network transmission is reduced, and the delay is effectively reduced to meet future HD video, VR/AR, and industrial Internet. At the same time, the operator's unique edge DC is its excellent advantage resource relative to OTT, which makes the edge computing have a wide application space.

Therefore, the GTI, as an industry consortium, hope to provide a platform for concerned parties to exchange their views and to develop the consensus for ecosystem guidance. This white paper will serve as a platform to initiate 5G MEC deployment strategy discussions within the GTI and be continuously updated based on the progress and consensus.

---

## 3 References

The following documents contain provisions which, through reference in this text, constitute provisions of the present document.

---

## 4 5G MEC Industry Progress

### 4.1 Introduction

The rapid growth of mobile services and the pressure of increasing operational costs will inevitably inspire the innovation and revolution in the telecommunications industry. New technologies and products are emerging, aimed at delivering better user experience, increasing profits, optimizing network operations, and improving resource utilization efficiency. Subscriber traffic increases constantly alongside the development of 4G. The fierce competition results in continuous increased size of user data package, and the roll out of unlimited data packages further causes the traffic on entire network to climb straightly. Massive traffic will pose challenges, these traffic flows transmit from the edge base station into the few central Data Centers, placing a heavy burden on the back-haul network. Operators have to expand the transmission network on a large scale. In addition, a large number of locally deployed OTT CDN and significant bench-marking tests like P3, Speed Test drive operators to deploy local gateways. Through the local gateways, the mobile service can use the local CDN to improve the mobile user experience and the benchmark score. There are also scenarios for data localization needs, such as campuses, enterprise campuses, venues etc, they also require locally deployed gateways. Then entire network and application local deployment solution to provide locally processed service, is called mobile edge computing (MEC) solution.

With the advent of 5G, the MEC application field further expands to enhanced mobile broadband (eMBB), massive machine-type communication (mMTC), and ultra-reliable and low-latency communication (uRLLC) scenarios, such as Internet of Vehicles (IoV), cloud AR/VR, cloud games, drones, HD live broadcasts and industrial controls etc. These new applications ask for higher demands on network capabilities, not only require lower service delays, but also require services to be optimized based on current user location, that means the edge network should know and manage the connection wherever the user moves. 5G networks need to provide edge mobility to new services, for example, cloud VR/AR, cloud games or ultra-high-definition live broadcasts, more and more video services in the future require high network bandwidth and low

latency, and the content sources used by the video are also getting larger and larger. This requires that 5G network provides edge computing to run services closely, and is able to position user location in real time, so that operators can achieve specific business optimization and data synchronization and enhance the user experience. In terms of edge mobility, taking the Internet of Vehicles as an example, as stated in 3GPP specifications, the Internet of Vehicles requires an end-to-end delay within 3ms, that means vehicles must maintain this ultra-low latency connection during movement, and the vehicle always choose the closest IoV controller(vehicle application server) to ensure service processing delay is within requirement. So when vehicles move out from old IoV controller coverage into a new one coverage, 5G network should perform a smooth handover from the old to the new without any service interruptions. Similar situations also occur in other new 5G scenarios, when bandwidth and latency requirements are combined with mobility requirement, it asks for the collaboration of applications and networks to meet those combined requirement. That's 5G MEC solution will do.

5G MEC is getting ready for commercial use to make mobile networks flexibly adapt to services, alongside the development of service requirements and maturity of standards and technical solutions. The 5G MEC era has gradually kicked off, enabling the network to flow as the business moves!

## 4.2 Standard Progress

The Multi-access Edge Computing (MEC) system consists of two parts, the first is the MEC application platform, and the second is the MEC edge network.

The ETSI MEC organization redefined MEC as Multi-access Edge Computing in early 2017, supporting 3GPP and non-3GPP multi-access. The ETSI MEC framework has now become a consensus of the edge computing framework in the telecommunications industry, those MEC standards focus on the deployment, management and orchestration of MEC platform and MEC applications. And the 3GPP standard focuses on edge network solutions including dynamic local breakout and edge mobility.

The basic framework of the MEC defined by ETSI is as follows:

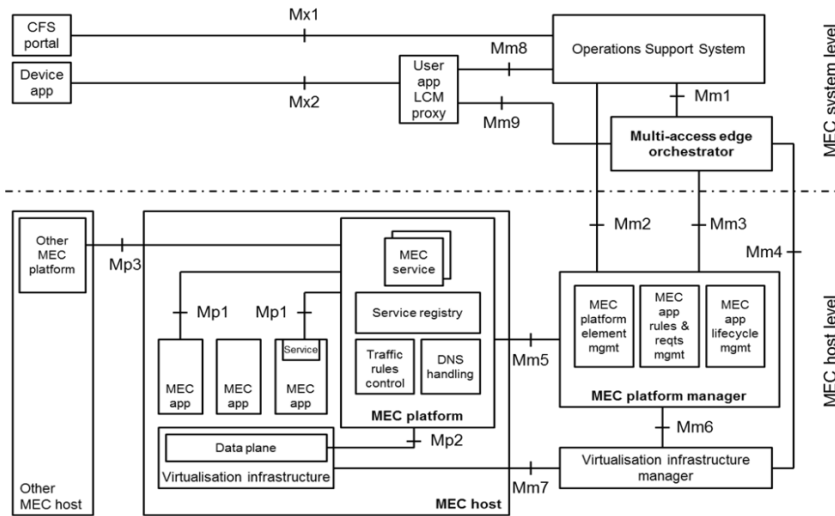

The MEC application platform includes Multi-access edge orchestrator, MEC platform manager and MEC Platform, ETSI is responsible for these three parts. Now is in the Phase 2 of the ETSI MEC standard progress, this phase enhances basic MEC architecture and functions, such as life-cycle management, service API principles, capability exposure and application enable, etc. 5G early application and interface definitions and emerging technologies such as container have been added in standard definition. At present, the MEC platform is able to initially support the MEC business pilot, but the standard details are still being improved, especially in MEC management and orchestration part. The Phase 2 is expected to freeze at the end of 2019. The early research of Phase 3 has been launched in September of 2018, and the goal of Phase 3 is the integration and promotion of 5G industry, including the research, interface design and test specification of new 5G services. MEC Standard time chart:

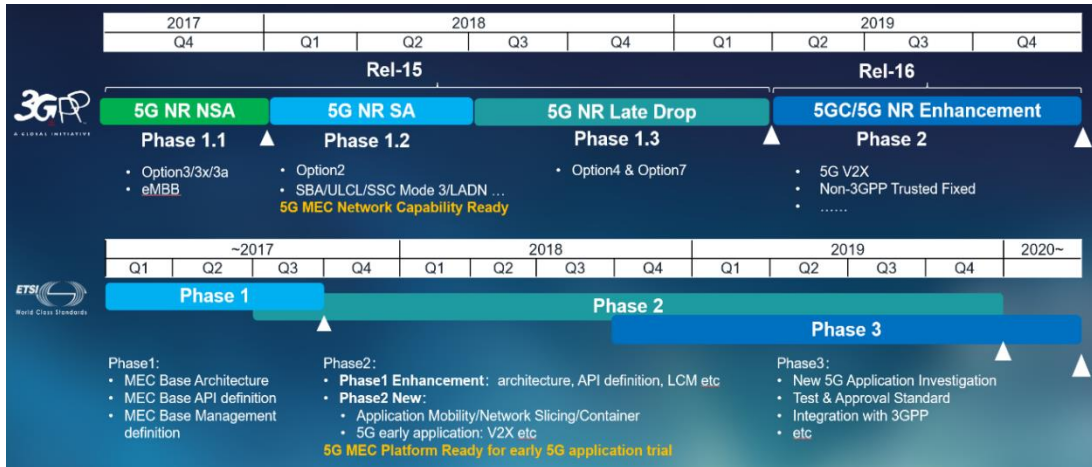

The MEC edge network includes Data Plane showed at bottom of figure1, which is a data gateway defined by the 3GPP standard, it provides network capabilities such as service local breakout, edge mobility etc in the MEC system, the gateway is called UPF in 5G. The Release 15 version of the 5G standard has been frozen in June 2018, and this version defines a complete UPF standard supporting technologies like ULCL, LADN, and SSC Mode 3 etc. The current UPF standard can fully support the MEC application requirement for the MEC edge network, so 3GPP standard is ready for MEC commercialization.

### 4.3 Business value and market demand

The fundamental purpose of Mobile Edge Computing (MEC) is to place computing and storage resources close to the end user's network to improve the latency of delivering content and applications to end users, increase the bandwidth of end-user access to services and content, and enhance users. Experience and enable ultra-low latency, ultra-high bandwidth network applications.

In the 4G era, the introduction of unlimited packages has led to rapid growth of traffic on the entire network. Massive data has created a challenge. These traffic imposes a heavy burden on the back-haul network. Operators need to expand the transmission network for this large scale. In addition, a large number of deployments of OTT CDN have led to differences in the experience of mobile networks and fixed networks. At the same time, services such as P3 and Speed Test have pushed the operators to split the previously deployed gateways and implement



distributed deployment of gateways. In this way, the mobile service can use the local CDN in the vicinity, which improves the service experience of the mobile user, saves the backbone network traffic, and saves the transmission cost. There are also some scenarios for data localization needs, such as campuses, enterprise campuses, venues, etc. They also need locally deployed gateways to ensure data and business localization.

In the 5G era, MEC will become the basic capability of 5G network services. For ultra-high bandwidth and ultra-low latency services of 5G, MEC is an essential basic network solution. MEC not only saves the value of transmission and enhances the experience, but also provides ultra-low latency communication capability for continuous coverage of services such as car networking, drone, cloud VR, etc., ensuring that users who use these services are outdoors. You can enjoy a business experience with ultra-low latency. In the 5G era, MEC will enable many new business scenarios for 5G.

## 4.4 MEC industry chain

The industry chain of mobile edge computing (MEC) includes telecommunications equipment vendors, operators, IT vendors, third-party applications and content providers, and industry cooperation is crucial. The position of each role in the industry chain:

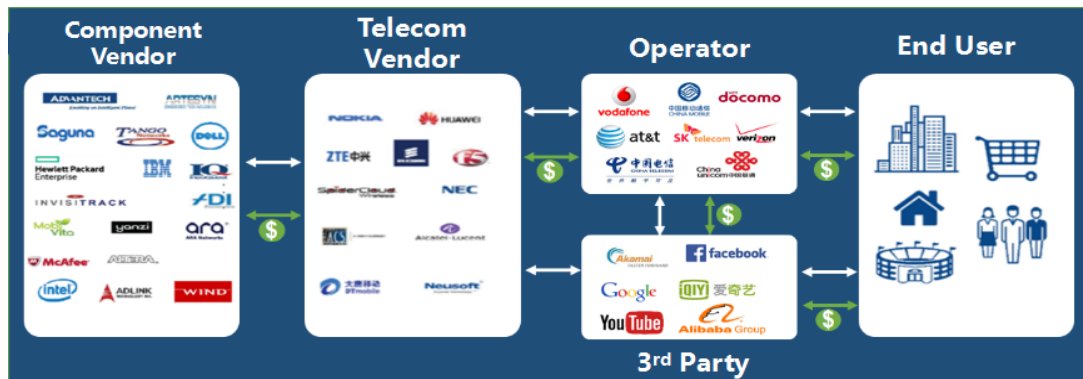

**Operator:** In the entire industry chain, the operator is a provider of MEC network services, deploying MEC networks for different application scenarios; operators have real estate space close to the end users for deploying MEC resources, so operators are MEC resources. owner. In the MEC industry chain, operators can provide services and content providers with a platform for

rapid deployment of applications and services through MEC solutions developed by telecommunications equipment vendors. The operator's MEC service platform allows service and content providers to schedule the required MEC resources (eg storage, computing) through the open interface and quickly deploy their own applications (eg monitoring video analysis, video and video streaming, IoT control) System operation);

Third-party applications and content providers: Third-party applications (including OTT vendors such as iQiyi, Google, YouTube, Facebook or video CDN applications such as Akamai) and content providers (such as HBO, Netflix, CNBC, BBC) are based on carrier offerings The MEC service platform loads personalized services to provide new value services or enhance service availability for end users.

telecommunications equipment vendors: telecommunications equipment vendors as operators of MEC equipment provide operators with core computing capabilities for edge computing.

Component suppliers: Telecommunications equipment vendors need Intel, telecommunications and other chip manufacturers to provide MEC business platform. In addition, due to the different needs of customers in various industries, telecommunications equipment vendors need ISVs (independent software developers) who understand the needs of the industry to provide customized software solutions to support and provide business integration capabilities. At the same time, telecommunications equipment vendors are also actively exploring cooperation with operators and third-party vendors. Therefore, in order to achieve rapid development, MEC must build a complete ecosystem, and its business model needs to be jointly developed by various manufacturers.

Focusing on the requirements and progress of MEC, technical characteristics and industrial cooperation requirements, the “MEC Technology Forum” will be carried out through joint operators, research institutes, equipment manufacturers and other industrial chain partners to jointly develop the MEC development plan. After several years of advancement, the industry generally believes that MEC will be a common model for building a 5G network edge cloud, and the industry chain has also accelerated MEC promotion, prompting the rapid development of this technology, which is applied to many practical projects of operators. Improve the business experience of online users. In 2019, the speed of mobile network evolution to 5G will be further

accelerated. MEC will play more value under the popularization of large-traffic services, thereby reducing the pressure on the core network and backbone transmission network, and improving the capability and value of the access network. Improve the user experience and promote the development of more business model applications.

## 4.5 MEC business progress

Mobile Edge Computing (MEC) provides a good platform and convergence node for future service providers, industry applications, and infrastructure providers, which will incubate more business and provide a better experience for customers. Bring new business value.

At present, the industry has reached two consensus on MEC. First, MEC is an important component of the future 5G network, and is an important business support point for the Internet of Everything. Second, the business is first, through the rapid development and evolution of the business-driven network.

As the fastest growing Internet and information technology country in the world, China provides a good foundation and first-mover advantage for the commercialization of new products and technology platforms. We have the responsibility and obligation to work together with the upstream and downstream of the industry chain to promote the maturity of the entire mobile edge computing industry and build a world-leading communications infrastructure.

Operators and vendors in GTI actively participates in international organizations such as 3GPP and ETSI, actively improves related technical solutions, and continues to share strength in standardization organizations. At present, it has taken the lead in the domestic CCSA to establish the 4G MEC standard project, and in 2018 led the 5G MEC platform technical specification requirements and test specification requirements, providing a unified standardization plan for the future MEC scale commercial use.

CMCC held the Edge Computing Summit on October 31, 2018, and jointly established the Open Computing Lab for Edge Computing in the industry. Together with the vertical industry partners in the 5G Lianchuang project, we will closely integrate edge computing technology with various vertical industry application scenarios. Edge computing applications for various industries are in the exploration phase.

Since 2015, The Operators has launched MEC application pilots in more than 20 local networks in 10 provinces across the country. For the mainstream new services such as HD video, AR/VR,LBS application, cross-layer traffic optimization, etc., joint industry partners to launch MEC business pilots to promote industry maturity.

## Leading the launch of 5G MEC pilot

**GTI has launched a variety of MEC pilots in more than 20 cities in 10 provinces, which has effectively promoted industrial maturity.**



### Wireless Cache/CDN

Hubei|Zhejiang|Shandong|Beijing

Zhejiang piloted the MEC-based CDN sinking, shortening the video buffer delay by about **20%**, increasing the download rate by about **30%**, and saving transmission bandwidth by **16%**.

### AR&VR/HD live video

Guangdong|Fujian|Zhejiang|Jiangxi

Guangzhou MEC-based VR cloud game at the end of 2017, local VR video rendering, business end-to-end delay reduced to **20ms**

### LBS Application

Beijing|Sichuan|Jiangsu|Guangdong

Beijing pilot smart shopping mall application, indoor positioning accuracy of **5m**, providing indoor navigation, passenger flow analysis and other location services

### Cross-layer Optimization

Zhejiang

Zhejiang is piloting a cross-layer optimization plan. The TCP slow start delay is expected to drop by **50%**; the throughput rate is increased by **30% to 45%**.



The User Plane Function (UPF) has a key role in an integrated MEC deployment in a 5G network. UPFs can be seen as a distributed and configurable data plane from the MEC system perspective. The control of that data plane, i.e. the traffic rules configuration, now follows the NEF-PCF-SMF route. Consequently, in some specific deployments the local UPF may even be part of the MEC implementation.

MEC is deployed on the N6 reference point, i.e. in a data network external to the 5G system. This is enabled by flexibility in locating the UPF. The distributed MEC host can accommodate, apart from MEC apps, a message broker as a MEC platform service, and another MEC platform service to steer traffic to local accelerators. The choice to run a service as a MEC app or as a platform service is likely to be an implementation choice and should factor in the level of sharing and authentication needed to access the service. A MEC service such as a message broker could be initially deployed as a MEC app to gain time-to-market advantage, and then become available as a MEC platform service as the technology and the business model matures.

Policies and rules in the 5G system are handled by the PCF. The PCF is also the function whose services an AF, such as a MEC platform, requests in order to impact the traffic steering rules. The PCF can be accessed either directly, or via the NEF, depending whether the AF is considered trusted or not, and in the case of traffic steering, whether the corresponding PDU session is known at the time of the request.

In the MEC system the MEC orchestrator is a MEC system level functional entity that, acting as an AF, can interact with the Network Exposure Function (NEF), or in some scenarios directly with the target 5G NFs. On the MEC host level it is the MEC platform that can interact with these 5G NFs, again in the role of an AF. The MEC host, i.e. the host level functional entities, are most often deployed in a data network in the 5G system. While the NEF as a Core Network function is a system level entity deployed centrally together with similar NFs, an instance of NEF can also be deployed in the edge to allow low latency, high throughput service access from a MEC host.

In MEC the services produced by the MEC applications are registered in the service registry of the MEC platform. To use the service, if authorized, a network function can directly interact with the network function that produces the service. The list of available services can be discovered from the NRF. Some of the services are accessible only via the NEF, which is also available to distrusted entities that are external to the domain, to access the service. In other

words, the NEF acts as a centralized point for service exposure and also has a key role in authorizing all access requests originating from outside of the system.

Finally another key concepts in 5G is Network Slicing that allows the allocation of the required features and resources from the available network functions to different services or to tenants that are using the services. The Network Slice Selection Function (NSSF) is the function that assists in the selection of suitable network slice instances for users, and in the allocation of the necessary Access Management Functions (AMF). A MEC application, i.e. an application hosted in the distributed cloud of a MEC system can belong to one or more network slices that have been configured in the 5G core network.

## 5.2 5G MEC overall deployment recommendations

In the future, 5G network evolution and network deployment will build a communication cloud infrastructure based on SDN/NFV/cloud computing. In order to cater to this trend and development, the future network architecture will adopt the communication cloud TIC layout, distribute and build the edge, the city, and the core TIC at different levels, and uniformly plan the communication cloud resource pool to achieve unified network architecture for multiple access such as solid network, mobile network and Internet of Things.

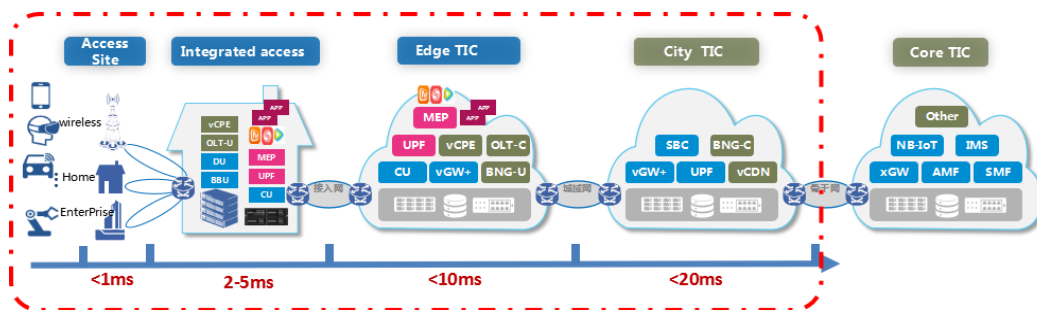

As shown in the figure, the communication network cloud architecture can be divided into four hierarchical units, including three layers of TIC and one layer of integrated access bureau. The specific features are as follows :

### 1) Core TIC

The core TIC is deployed in the regional or provincial core bureau, serving the regional or provincial business, deploying regional or provincial operational management centers, such as the group OSS/NFVO, provincial cloud management platform, NFVO, VNFM, etc.; The core network control planes in the inner or the provincial area include the AMF, SMF, MME, and NB-IoT core networks; the media plane centrally controls the network elements such as the network element IMS. The core TIC performs unified management of network elements, unified network management, and unified management of infrastructure. The core TIC also implements NFVO and OSS collaboration. NFVO is responsible for virtual network scheduling, resource management, fault alarm, etc. OSS is responsible for business and resource coordination, as well as traditional network management. NFVO and OSS work together to realize unified management of traditional networks and virtual networks.

## **2) City TIC**

The TIC deployment location of the city is located in the prefecture-level city and the key county-level cities in the province. It mainly carries the control network element of the metropolitan area network and the centralized media plane network element, and serves the service, control plane and part of the user plane network element of the local network, including CDN, SBC, BNG-C, UPF, GW-U, etc.

## **3) Edge TIC**

The edge TIC is mainly deployed in the transmission aggregation bureau. The edge TIC mainly terminates the media stream function and performs forwarding. The access layer and the edge computing network element are mainly deployed. The network elements of the 5G RAN-CU, MEC, BNG-U, OLT-U, and UPF can be flexibly deployed on the edge TIC according to the service features of low-latency and high-bandwidth. The deployment of the edge TIC can deploy resources such as the cloud service environment, computing, storage, network, and acceleration to the edge of the network, enabling closer integration of various applications and networks, and users will also obtain more abundant network resources and service services.

## **4) Integrated access bureau**

The integrated access bureau is mainly to enhance resource intensiveness and meet the user's extreme experience, and achieve unified access and unified bearer for users such as the



public/political enterprise, mobile/fixed network. The integrated access bureau is widely distributed, and the lowest deployment location can be located in the village. Therefore, service scenarios with high latency and bandwidth requirements, such as 5G CU, DU, MEC, and vCPE, can be deployed to the integrated access bureau as needed.

### 5.3 5G MEC development solution in 5GC

3GPP SA2 network architecture clear support for edge computing : Edge computing enables operator and 3rd party services to be hosted close to the UE's access point of attachment, so as to achieve an efficient service delivery through the reduced end-to-end latency and load on the transport network.

The 5G Core Network selects a UPF close to the UE and executes the traffic steering from the UPF to the local Data Network via a N6 interface. This may be based on the UE's subscription data, UE location, the information from Application Function (AF) .

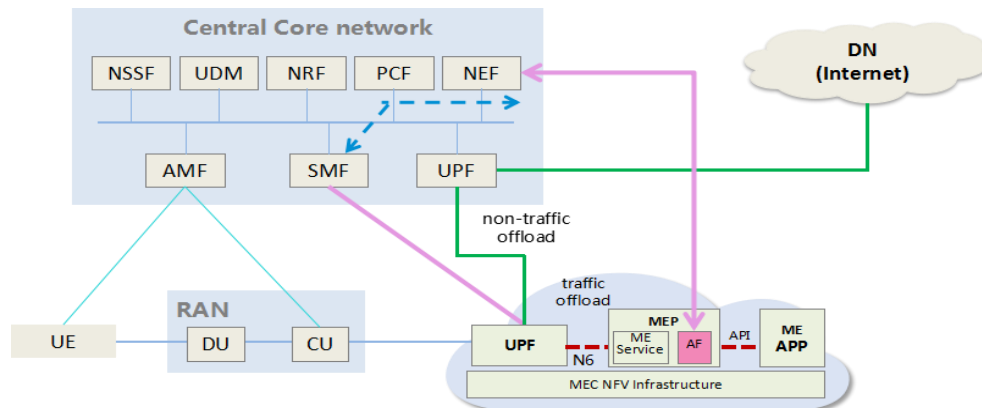

And 3GPP clear defined that Edge computing can be supported by one or a combination of the following enablers:

- **User plane (re)selection:** the 5G Core Network (re)selects UPF to route the user traffic to the local Data Network
- **Local Routing and Traffic Steering:** the 5G Core Network selects the traffic to be routed to the applications in the local Data Network
- **Session and service continuity:** to enable UE and application mobility

- **An Application Function may influence UPF (re)selection and traffic routing:** via PCF or NEF;
- **Network capability exposure:** 5G Core Network and Application Function to provide information to each other via NEF
- **QoS and Charging:** PCF provides rules for QoS Control and Charging for the traffic routed to the local Data Network;
- **Support of Local Area Data Network:** 5G Core Network provides support to connect to the LADN in a certain area where the applications are deployed

### 5.4 5G MEC management and orchestration solution

Management and orchestration provides operators with an automated, efficient deployment, management, and maintenance capabilities for future deployments of MEC. Since the MEC is an integrated network element that combines IT and CT, the management orchestration function of the MEC needs to comply with the security and standardization required by the operator for telecommunication network element management, and also consider the flexibility of the Internet for application deployment. The ETSI standard gives the MEC management orchestration reference architecture.

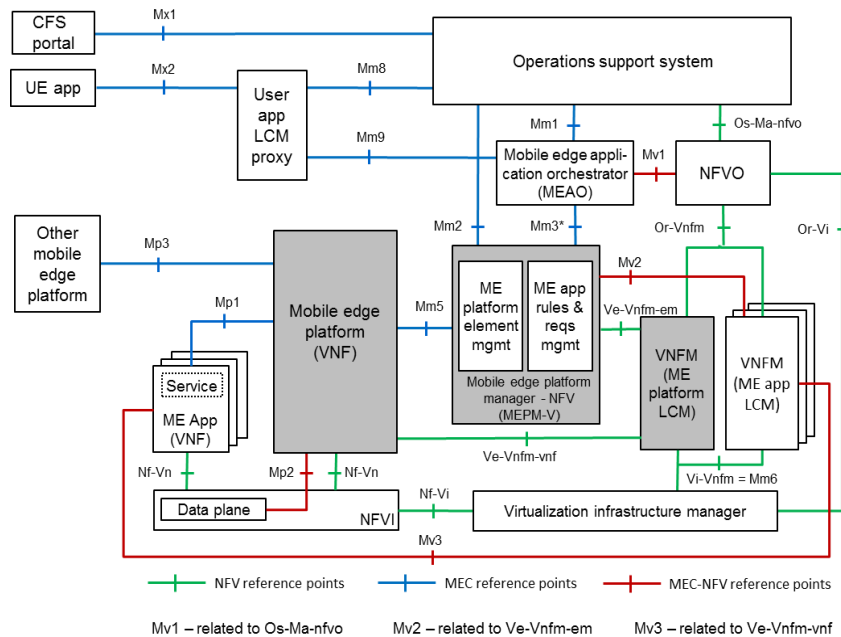

In This reference architecture, the management and orchestration of MEC is divided into two parts

- The management and orchestration of MEP: NFVO、VNFM(ME platform LCM)、MEPM(ME platform element management)
- The management and orchestration of 3rd APP: MEAO、VNFM(ME app LCM)、MEPM(ME app rules & requirements management)

The MEP orchestration comply with the operator's NFV standards, the NFVO is responsible for the MEP' s resource orchestration, the VNFM (ME platform LCM) is responsible for the MEP's life-cycle management, MEPM(ME platform element management) is responsible for the MEP's network element management.

In the reference architecture given by ETSI, the 3rd APP' s orchestration is responsible for MEAO, which is independent of NFVO. When the APP is deployed in the form of VNF, it will through NFVO to launch. and the 3rd APP is managed by VNF (ME app LCM), ME app rules & requirements management) Manage third-party apps accordingly.

## 5.5 5G MEC Network Capability Openness

As an edge service enabling platform, MEC provides a virtual platform for the deployment of edge services. On the other hand, it can provide capabilities and open these to serve third-party applications and manage them. It can provide basic network service capabilities to third-party application consumption safely and efficiently, and can also realize reliable sharing of service capabilities among third-party applications, and promote rich edge application ecology to meet various edge application scenarios. The following capabilities that MEC can provide as examples.

### **Multi-access network traffic offload capability:**

The traffic offloading service that supports multiple network access standards is the vision of MEC and also is the most basic function. By local traffic offload service the MEC terminate app

traffic at the edge of the network, the end-to-end delay of the service can be greatly reduced, the bandwidth cost of the network back-haul can be saved. In the 5G era, with the new services such as AR/VR, artificial intelligence, vehicle networking, and real-time industrial control, the demand for local unloading of services will become more urgent and common.

The diversity of the new services, determines the diversity of its network access standards. Currently, common wireless and fixed access systems such as 4G, 5G, NB-IOT, and fixed networks; Also non-operator networks such as Bluetooth, Wifi, and LoRa, the MEC platform needs to have the ability to support multi-network convergence to adapt to various application scenarios.

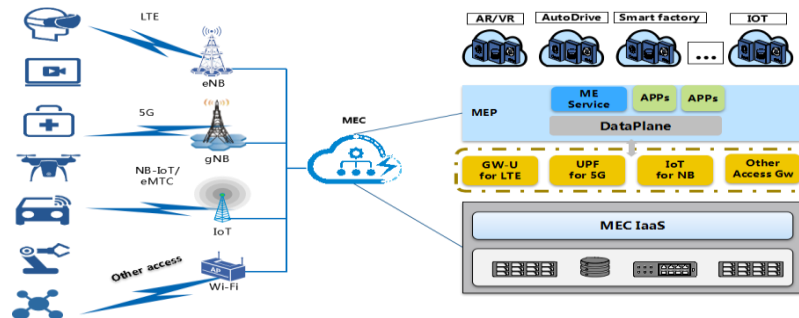

### Indoor Location Service:

MEC can combine with the indoor distributed base stations to create a smart indoor system, which enables operators to realize the commercial value of indoor high-value traffic scenarios by opening user location information. For large-scale commercial, railway stations, airports and other scenarios. Business precision marketing, online payment, and mobile advertising business are concentrated, and demand for indoor location services is strong, and business models and business innovation needs are urgent.

Through the operator standardized the south interface between the MEC and base station, and the north interface (API) of between the MEC and the 3rd APP, the operator can real-time collection the indoor user location and can provide to the 3rd APP through the API interface. The closed loop of functionality to commercial value realization.

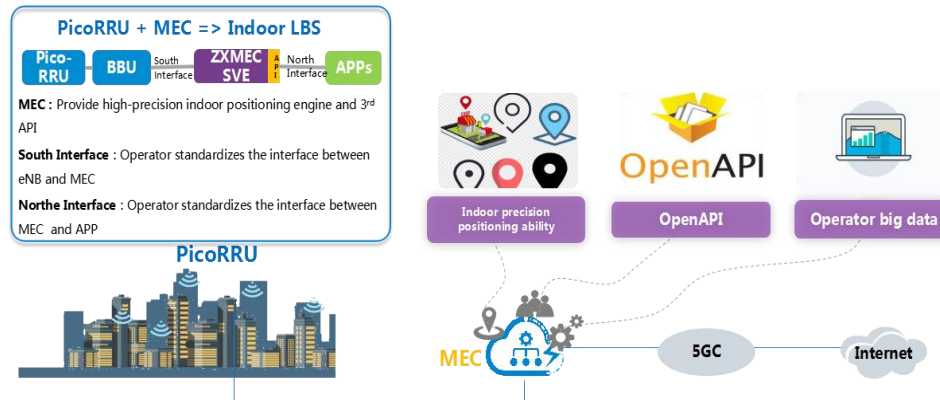

### Edge intelligent service capability:

Artificial intelligence has been deployed in more and more new business areas, and has greatly improved the efficiency of business operations and reduced the cost of application execution. However, in the practical application fields such as the Internet of Vehicles and smart cities, the demand for lower latency and higher execution efficiency is also proposed for AI training and prediction. These requirements drive the deployment and landing of AI deployment at the edge of the network.

On the one hand, edge AI is used for industry applications, such as real-time video recognition at the edge in smart cities, vehicle identification and obstacle recognition in the Internet of Vehicles. AI training is deployed in the cloud, and predictive deployment is at the

edge, which greatly increases the system response rate.

On the other hand, the edge AI serves the Operator's network, based on real-time measurement statistics (channel interference, signal strength, network load, etc.) on the network side, and the user's traffic model (such as user location, mobility, service type, real-time rate, data packet etc), predict the real-time judgment of the network and further behavior of the user, generate optimal parameter configuration suggestions and network resource configuration suggestions, and assist the network to make resource allocation decisions.

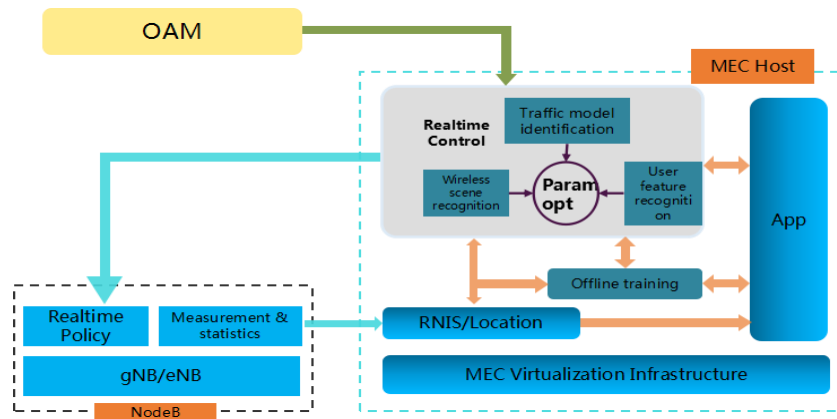

### Radio network information service(RNIS):

Operator can open the wireless network information service (RNIS) through the MEC. After obtaining the RNIS service authorization, the related application obtains the real-time information of the wireless network. The RNIS can flexibly distinguish the granularity of the openness of the wireless network information (cell level, user level, QCI level) to meet the needs of different levels of business optimization. RNIS includes the following information:

- 1) Real-time wireless network status information
- 2) UE's measurement and statistics (CQI、SINR、BLER)
- 3) UE wireless bear information

**Basic IT capabilities:**

As a edge infrastructure, MEC provides edge cloud infrastructure IT resources and capabilities. Including external resources such as basic computing, storage, networking, and acceleration, as well as remote operation and maintenance of these resources.

As the main resource of the edge cloud infrastructure, computing resources need to provide powerful virtualization and computing capabilities to meet the needs of MEC's many application deployments. Storage capacity is one of the basic capabilities of an edge cloud infrastructure. It can be a local disk method that is tightly coupled with computing resources, or it can be a separate storage module resource sharing method. For edge computing, supporting heterogeneous computing architectures, providing hardware acceleration resources is a necessary requirement for future edge AI and local video processing. Therefore, hardware acceleration capabilities such as FPGA, GPU, and ASIC are required.

The relative location of the equipment room deployed by the edge cloud hardware device is relatively low, the number is large, and the environment of some computer rooms is poor. There is an unattended scenario. Therefore, the hardware system architecture should support remote operation and maintenance and reduce labor costs. The hardware architecture supports a separate out-of-band management plane, providing a node-independent dedicated management network for managing the health of components on the node, such as CPU, fan, system temperature, voltage, etc., independent of the main processor. The state of the business software impact. And support remote operation and maintenance, adapt to the unattended scene of the edge cloud room.

## 6 MEC Key Solution and Innovation

### 6.1 ETSI MEC reference architecture

The MEC framework shows the general entities involved. These can be grouped into system level, host level and network level entities. The detail as below:

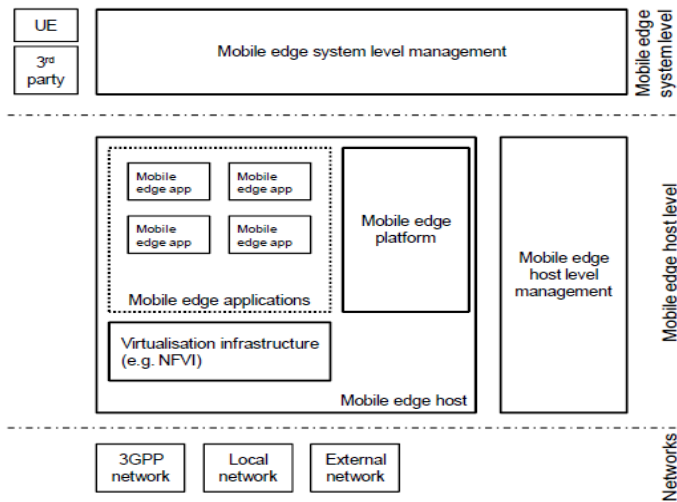

- mobile edge host, including the following:
  - mobile edge platform;
  - mobile edge applications;
  - virtualization infrastructure;
- mobile edge system level management;
- mobile edge host level management;
- external related entities, i.e. network level entities.

#### Reference architecture

The reference architecture shows the functional elements that comprise the MEC and the



reference points between them.

Below Figure depicts the MEC reference architecture. There are three groups of reference points defined between the system entities:

- reference points regarding the MEC functionality (Mp);
- management reference points (Mm); and
- reference points connecting to external entities (Mx).

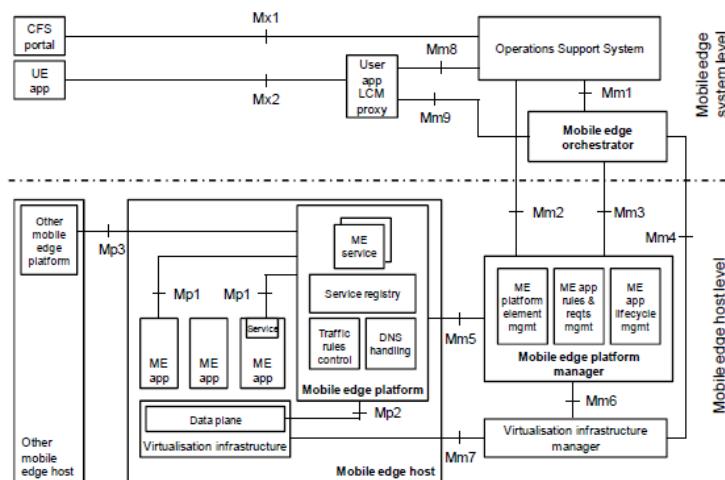

The mobile edge system consists of the mobile edge hosts and the mobile edge management necessary to run mobile edge applications within an operator network or a subset of an operator network.

The mobile edge host is an entity that contains a mobile edge platform and a virtualization infrastructure which provides compute, storage, and network resources, for the purpose of running mobile edge applications.

The mobile edge platform is the collection of essential functionality required to run mobile edge applications on a particular virtualization infrastructure and enable them to provide and consume mobile edge services. The mobile edge platform can also provide services.

Mobile edge applications are instantiated on the virtualization infrastructure of the mobile edge host based on configuration or requests validated by the mobile edge management.

The mobile edge management comprises the mobile edge system level management and the mobile edge host level management.

The mobile edge system level management includes the mobile edge orchestrator as its core component, which has an overview of the complete mobile edge system. The mobile edge host level management comprises the mobile edge platform manager and the virtualization infrastructure manager, and handles the management of the mobile edge specific functionality of a particular mobile edge host and the applications running on it.

### **MEC reference architecture in NFV environments**

A consolidated vision of the MEC system is about deploying it as part of an NFV environment where MEC applications would be deployed as Virtual Network Functions (VNFs).

It is assumed that the ME app VNFs will be managed like individual VNFs, allowing that a MEC in NFV deployment can delegate certain orchestration and Life Cycle Management (LCM) tasks to the NFVO and VNFM functional blocks, as defined by ETSI NFV MANO.

One goal of the present study is to describe that actual mapping, to elaborate on a high level how MEC orchestration procedures and ME application LCM procedures can be realized in such an environment.

The Mobile Edge Platform Manager (MEPM), as defined in the MEC reference architecture ETSI GS MEC 003 [i.5], is transformed into a "Mobile Edge Platform Manager - NFV" (MEPM-V) that delegates the LCM part to one or more VNFM(s). The Mobile Edge Orchestrator (MEO), as defined in the MEC reference architecture ETSI GS MEC 003 [i.5], is transformed into a "Mobile Edge Application Orchestrator" (MEAO) that uses the NFVO for resource orchestration, and for orchestration of the set of ME app VNFs as one or more NFV Network Services (NSs).

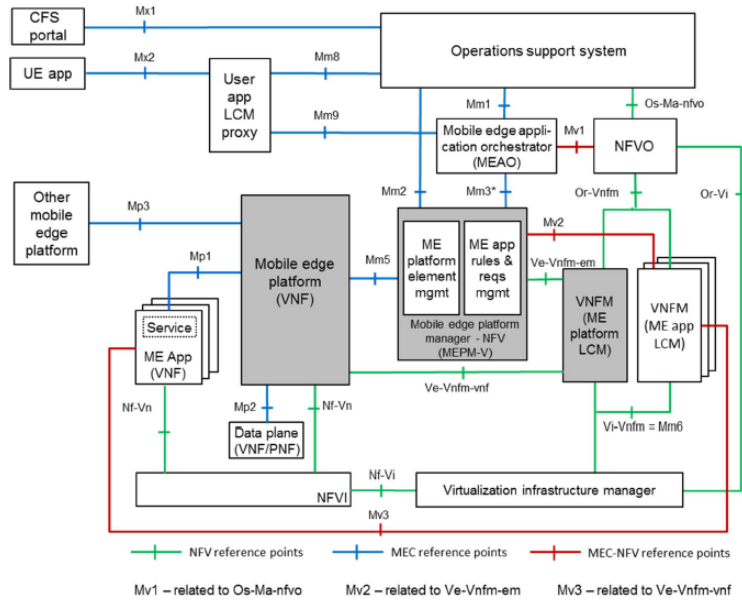

NOTE 1: It is assumed that the Mobile Edge Platform VNF, the MEPM-V and VNFM (ME platform LCM) will be deployed as a single package as per the ensemble concept in 3GPP TR 32.842 [i.8], or that the VNFM is a Generic VNFM as per ETSI GS NFV-IFA 009 [i.9] and the Mobile Edge Platform VNF and the MEPM-V are provided by a single vendor.

NOTE 2: The Mp1 reference point between an ME application and the ME platform is optional for the ME application, unless it is an application that provides and/or consumes a ME service (ETSI GS MEC 003 [i.5], Figure 6-1).

NOTE 3: The Mm3\* reference point between MEAO and MEPM-V is based on the Mm3 reference point, as defined by ETSI GS MEC 003 [i.5]. Changes will be needed to this reference point to cater for the split between MEPM-V and VNFM (ME applications LCM).

The following new reference points (Mv1, Mv2 and Mv3) are introduced between elements of the ETSI MEC architecture and the ETSI NFV architecture to support the management of ME app VNFs. These are related to existing NFV reference points, but it is expected that only a subset of the functionality will be used for ETSI MEC, and that extensions may be necessary:

- Mv1: This reference point connects the MEAO and the NFVO. It is related to the Os-Ma-nfvo reference point, as defined in ETSI NFV.

- Mv2: This reference point connects the VNF Manager that performs the LCM of the ME app VNFs with the MEPM-V to allow LCM related notifications to be exchanged between these entities. It is related to the Ve-Vnfm-em reference point as defined in ETSI NFV, but will possibly include additions, and might not use all functionality offered by Ve-Vnfm-em.

- Mv3: This reference point connects the VNF Manager with the ME app VNF instance, to allow the exchange of messages e.g. related to ME application LCM or initial deployment-specific configuration. It is related to the Ve-Vnfm-vnf reference point, as defined in ETSI NFV, but will possibly include additions, and might not use all functionality offered by Ve-Vnfm-vnf.

The following reference points are used as they are defined by ETSI NFV:

- Nf-Vn: This reference point connects each ME app VNF with the NFVI.
- Nf-Vi: This reference point connects the NFVI and the VIM.
- Os-Ma-nfvo: This reference point connects the OSS and the NFVO. It is primarily used to manage NSs, i.e. a number of VNFs connected and orchestrated to deliver a service.
- Or-Vnfm: This reference point connects the NFVO and the VNFM. It is primarily used for the NFVO to invoke VNF LCM operations.
- Vi-Vnfm: This reference point connects the VIM and the VNFM. It is primarily used by the VNFM to invoke resource management operations to manage the cloud resources that are needed by the VNF. It is assumed in a NFV-based MEC deployment that this reference point corresponds 1:1 to Mm6.
- Or-Vi: This reference point connects the NFVO and the VIM. It is primarily used by the NFVO to manage

The key to a successful management integration of MEC platforms, regardless of their deployment site, is to support standard modes of management, be it IPMI-based management at a very low level, SNMP, modern REST-based protocols or DMTF's Redfish, all of which connect into the operators' network management solutions. Whether Open Source MANO, ONAP or other open- or closed-source solutions, they all offer interfaces into these standard technologies.

As MEC moves closer to standard data centre practices, wherever there is a non-standard management approach, typically the integration will become tedious, and, in some cases, even fail.

## 6.2 MEC Virtualization Solution

There is a growing consensus that in the long term, 5G deployments will increasingly integrate fixed-mobile networks infrastructures with cloud computing and MEC. In these future scenarios, the borders between cloud and MEC virtual resources will blur, paving the way towards a sort of “continuum” of logical resources and functions, offering flexibility and program-ability through global automated operations.

On the other hand, in 5G future service infrastructures, IaaS will assume a new meaning, as the CPU, storage, and network resources are not only provided by a collection of data centers, but also by the CPU, storage, and network resources deployed into the Points of Presence (PoPs) of the telecommunications network (in its core, edge and access segments). The PaaS layer will feature a pool of software appliances that facilitate the end-to-end life-cycle of developing, testing, deploying, and hosting services and applications. Some examples of these appliances are databases, web servers, application servers, Apache Hadoop, Apache Storm, and load balance, each of which will be integrated with other network appliances (e.g., telecommunications/internet middle-boxes) to design complex service chains, functions and applications. SaaS will integrate multiple, interoperable PaaS and IaaS resources to deliver services and applications to the end users.

MEC enables the implementation of mobile edge applications as software-only entities that run on top of a virtualization infrastructure, which is located in or close to the network edge.

Distributed edge clouds bear various applications, resulting in a quite heterogeneous architecture

- Common server & customized server
- VM & container & Bare metal

- VNF & PNF

## 6.3 5G MEC security solution

The MEC server is a brand new type entity in the mobile network. While connecting to several mobile network entities including OAM system, UPF, Lawful Interception etc., it also connects to the 3rd party application server, and even accommodates the 3rd party application. It is noted that current security techniques including IP sec, TLS, firewall etc. could secure these connections to block the attack to the MEC server, mobile system and the 3rd party server. However, these solutions are not enough with the new security issues with the introduction of MEC. For example, a malicious app running in the MEC server could intentionally occupy the resource in the sever, which may disable the application in the same server; the app can also use the API to freely change the configuration of the mobile network, which may harm the whole network performance. Although the resource isolation, configuration parameter range limitation and other solutions may relieve the impacts of the attacks, they can't neutralize the attacks fundamentally.

It is necessary to setup a unified, credible security evaluation system to evaluate the security of the applications running in the MEC system, which will guarantee only the trusted 3rd party application in the server. In the meantime, the security aspects of the interface between the application and the network shall also be considered to safe the communication, e.g. the unauthorized invocation.

The mobile operator could provide the service to shield the application in the MEC server from the malicious attack, and also check the security bugs of the 3rd party apps.

The specific security requirements of MEC are described in detail below:

1) Physical facility protection: while providing users with high-quality services, MEC's on-demand adjacent deployment also objectively shortens the distance between attackers and MEC's physical facilities, making attackers more vulnerable. More likely to come into contact with MEC physical facilities, resulting in the destruction of MEC physical equipment, service interruption, user privacy and data leakage and other serious consequences. On the other hand,

widely deployed MEC edge computing nodes also face the threat of various natural disasters (such as typhoons, hail) and industrial disasters. All of the above factors may directly damage the MEC hardware infrastructure, causing sudden service interruption and unexpected loss of data. Therefore, it is necessary to equip MEC nodes with corresponding physical facility protection measures on the basis of performance and cost considerations.

2) Security protection of MEC nodes with limited security capability: the security protection ability of a single MEC node (such as the type of attack that can be resisted and the strength to resist a single attack, etc.) is limited due to a variety of factors such as performance, cost and deployment flexibility requirements. Therefore, it is necessary to deploy corresponding security protection measures targeted at the application characteristics and terminal characteristics of MEC nodes (IoT terminal/mobile intelligent terminal). By making full use of the highly cooperative characteristics of MEC nodes, the upper limit of attack strength that a single node can resist can be increased by using the idle security protection resources of surrounding nodes through technologies such as security protection based on intelligent collaboration.

(3) Extended trust model construction: the deployment mode of symbiotic integration of MEC system and mobile communication system expands the previous binary trust relationship construction model of "users respectively authenticate with the network and services". It is necessary to build the trust relationship among users, MEC system, MEC application, mobile communication network and MEC system. To be specific, it is necessary to build the trust relationship between the MEC system and 5G network so as to legally use 5G open network services (such as local triage) to provide services to users. It is necessary to build the trust relationship between MEC system and MEC applications to prevent malicious applications from taking over user services. The trust relationship between MEC system and users needs to be built to confirm the legitimacy of MEC system and users. Within the MEC system, it is necessary to build the trust relationship between MEC nodes and MEC controllers to prevent "false MEC nodes" from malicious access to steal user and service information. Trust relationships between MEC nodes need to be built to support collaboration between nodes.

4) Privacy and data protection: the characteristics of MEC" high-quality and personalized service based on user information perception "not only provide convenience, but also make MEC

applications inevitably have access to a large number of privacy and data information of mobile users and devices, such as user identity, location and mobile trajectory. After further mining these information, we can also get a lot of information about users' sleep patterns, living habits, health conditions and so on. Therefore, in MEC privacy and data protection, it is necessary to equip with corresponding privacy leakage protection measures to strictly control the behavior of third-party MEC applications and prevent them from leaking and abusing users' privacy and data information. It is necessary to weaken the mapping relationship between MEC computing node identity and geographical location through technologies such as dynamic identity identification and anonymity, so as to prevent the third party from inferring the user's geographical location based on the location of MEC node. Need to ensure the safe storage of data in the edge; Privacy and data management services need to be provided to users to ensure that privacy policies are adaptable to users.

## 6.4 5G MEC hardware acceleration solution

With the emergence of 5G, lots of new service with specific requirement for low latency, high bandwidth and huge multi-case packet load comes into being, making the extension of cloud to edge quite important so as to meet latency requirement and save transport resources.

Service for Edge:

- User plane services: SAE-GW, UPF
- Low Latency Services: VR, automatic driving
- High Throughput services: AR, Video surveillance
- Services with huge requirement for multicast: IPTV
- High Speed Mobile Services: UAV



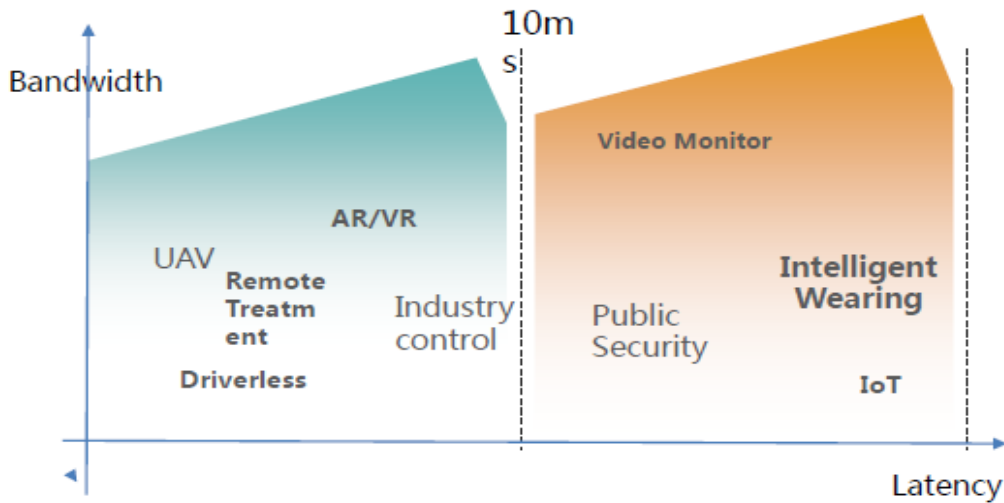

Different applications require more hardware acceleration on the edge platform, Based all of these request, SR-IOV, Smart NIC and GPU will be the most important acceleration solution for MEC hardware.

SR-IOV technology standard allows efficient sharing of PCIe (Peripheral Component Interconnect Express) devices among virtual machines, and it is implemented in hardware to achieve I/O performance comparable to that of this machine. The SR-IOV specification defines a new standard based on which new devices can be created to allow virtual machines to be connected directly to I/O devices.

Smart NIC can improve application and virtualization performance, realize many advantages of software-defined network (SDN) and network function virtualization (NFV), remove network virtualization, load balancing and other low-level functions from server CPU, and ensure maximum processing capacity for application. At the same time, Smart NIC can also provide distributed computing resources, allowing users to develop their own software or provide access services, thus accelerating specific applications.

GPU (graphics processor unit) mainly carries on the floating point arithmetic and parallel computing, the floating point arithmetic and parallel computing speed can be one hundred times more than the CPU, using the GPU virtualization technology, can let run the virtual machine in a data center server instance Shared using the same or more blocks of GPU

processors for graphics operations, MEC platform a large number of video to accelerate business applications, such as VR/AR/cloud game, both to the edge of the platform of GPU ability put forward higher requirements.

## 6.5 Mobility management of edge services in 5G network

Edge computing enables operator and 3rd party services to be hosted close to the UE's access point of attachment, so as to achieve an efficient service delivery through the reduced end-to-end latency and load on the transport network. Edge Computing typically applies to non-roaming and LBO roaming scenarios.

The 5G Core Network selects a UPF close to the UE and executes the traffic steering from the UPF to the local Data Network via a N6 interface. This may be based on the UE's subscription data, UE location, the information from Application Function (AF), policy or other related traffic rules.

Due to user or Application Function mobility, the service or session continuity may be required based on the requirements of the service or the 5G network.

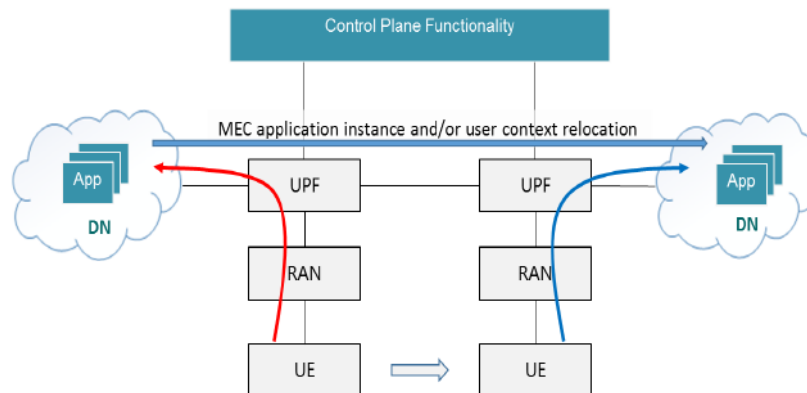

The 5G Core Network may expose network information and capabilities to an Edge Computing Application Function. Depending on the operator deployment, certain Application Functions can be allowed to interact directly with the Control Plane Network Functions with

which they need to interact, while the other Application Functions need to use the external exposure framework via the NEF.

Edge computing can be supported by one or a combination of the following enablers:

- User plane (re)selection: the 5G Core Network (re)selects UPF to route the user traffic to the local Data Network ;
- Local Routing and Traffic Steering: the 5G Core Network selects the traffic to be routed to the applications in the local Data Network;
- This includes the use of a single PDU Session with multiple PDU Session Anchor(s) (UL CL / IP v6 multi-homing) .
- Session and service continuity to enable UE and application mobility ;
- An Application Function may influence UPF (re)selection and traffic routing via PCF or NEF;
- Network capability exposure: 5G Core Network and Application Function to provide information to each other via NEF;
- QoS and Charging: PCF provides rules for QoS Control and Charging for the traffic routed to the local Data Network;
- Support of Local Area Data Network: 5G Core Network provides support to connect to the LADN in a certain area where the applications are deployed .

Application mobility is a unique feature of the MEC system. It is necessary to be able to relocate a user's context and/or application instance from one MEC host to another to continue offering an optimized service experience for the user. Application mobility is a part of service continuity support, in which the service to the UE will resume once the user's context and/or application instance has been relocated to another MEC host. The following figure illustrates the basic scenario for application mobility in an integrated MEC deployment in a 5G network.

The MEC application mobility feature is a work in progress in ETSI ISG MEC. The current definitions of the feature are grouped into procedures that may or may not apply depending on the characteristics of the application, environment and capabilities of the MEC host, MEC orchestrator and also of the MEC application itself. The procedures that are currently being

developed are application mobility enabled, detection of UE movement, validation of application mobility, user context transfer and/or application instance relocation, and post-processing of application relocation. Ways in which a mobile UE application client may contribute to the enabled of the application mobility service to achieve the service continuity of the application are also being considered.

In the MEC environment, an MEC AF (Application Function) may send request for a PDU session to influence SMF traffic routing decision and UPF (User Plane Function) selection. According to the 3GPP definition, AF request can be sent to PCF via N5 interface or NEF (network exposure function), if multiple UEs are involved, the request can be forwarded to multiple PCFs via NEF or directly delivered to the PCFs. The AF request may contain following information affecting UPF selection:

- Potential locations of applications towards which the traffic routing should apply, the potential locations can be indicated by a list of DNAI, where the DNAI is used by SMF to select UPF. If the AF interacts with the PCF via the NEF, the NEF may map the AF-Service-Identifier to a list of DNAI.
- Information of UEs whose traffic are to be routed, including External Identifier, a MSISDN, an IP address/Prefix, or External Group Identifier.
- Information on when the traffic routing is to apply.
- UE location information when the traffic routing applies.

Based on the AF request, the PCF can provide SMF with PCC rules that may contain information about the DNAI(s).

The DNAI can be used by the SMF to select PDU session anchor or update the user plane path. While performing UPF selection, the SMF needs also take UE location information, e.g. cell ID/TAI, into account to select an appropriate user plane anchor.

For a UE that is obtaining MEC service, the network should apply distributed mobility management mechanism, in which the SSC (session or service continuity) mode of the PDU session for MEC service is set to SSC mode 2 or 3 (the definition of SSC mode can be found in

3GPP TS 23.501), then when the relocation of PDU session anchor is required due to UE mobility, the SMF can notify the UE to establish another PDU session toward same DN (data network). When the SMF receives PDU session establishment request, the SMF can select a new UPF as the PDU session anchor, which allow the UE to continue visit MEC service. The previously established PDU session for MEC service can be release (based on different SSC mode, the release operation may be before or after the new PDU session establishment).

## 6.6 5G MEC charging solution

The 5GC charging supports collection and reporting of charging information for network resource usage, The SMF supports the interactions towards the charging system, The UPF supports functionality to collect and report usage data to SMF. The N4 reference point supports the SMF control of the UPF collection and reporting of usage data.

The traffic between mobile edge application and UE is routed by UPF. UPF implements the traffic charging for terminal consumer and compliance with the 3GPP standard. MEC platform implements the application related charging.

Chargeable events are those events that provide Charging and Billing functions with information for billing purposes. Information can be related to usage of resources or management tasks, such as instantiation, scaling, and termination of applications. Based on these chargeable events, MEC generates data records and reports to the billing center. The chargeable events can be classified into three categories:

- Resource usage events. These are events which provide the information of virtualization resources usage in volume/duration or combination of both.
- Management and orchestration events. These are events which provide the information of management API calls, such as instantiation, migration, and termination of applications.
- Capability exposure API calling events. These are events which provide the information of application calls the APIs provided by MEC platform or network.

MEC needs to support the off-line charging and on-line charging:

- Off-line charging: MEC periodically collects and reports the resource usage records, management and orchestrator data records and capability exposure API call data records to the offline charging function to aggregate and correlation. Billing uses the aggregated/correlated event records to charge the consumer at the end of the billing cycle.
- On-line charging: Upon first chargeable event of a consumer, MEC triggers an online charging request towards online charging function to get a granted quota. When the allocated quota is almost fully used, MEC reports the usage of the resource and requests for additional quota from the online charging function. The charging function may allocate a new quota or deny it. In case of denial, MEC will reject the resource usage request or API calling request.

The integrated deployment of MEC in a 5G system relies on the UPF as the PDU session anchor and gateway to data networks where the MEC environment is deployed. Consequently, the same charging mechanisms and capabilities apply as apply to non-MEC applications.

The transformation of the telco networks into 3rd party service hosting environments where the application cloud becomes an integral part of the telco network calls for new approaches in charging principles and capabilities. Along with the tight integration between 5G NFs such as UPF and SMF and MEC, it is expected that the support of both online charging and offline charging will be relatively straightforward, which would allow 3GPP compliant MEC deployments with charging natively supported for MEC applications.

## 7 Use Case and Trial

### 7.1 VR Cloud Gaming

VR is a typical 5G eMBB service. The VR service requirements for the network are as follows:

Typical VR head resolution	Bandwidth(Mbps)	TimeDelay (ms)
4K (2K*2)	25~100	20ms
8K (4K*2)	100~400	20ms

Deploy VR services on the MEC platform of the 5G network, deploy VR video rendering, video acceleration, video encoding and decoding, etc. to the network edge. On the one hand, it will bring ultra-low latency to meet VR service requirements, and at the same time make VR head display only collect user location information without processing, effectively reducing head-up cost, reducing size, and power consumption, making VR services easier to promote and bringing better experience.

Joint Tencent game, successfully carried out 5G+MEC+VR cloud game pilot, VR game real-time media processing in edge computing unit, GPU image rendering, reducing end-to-end service delay to 10ms, single-channel VR rate up to 440Mbps, game Clear and smooth picture.

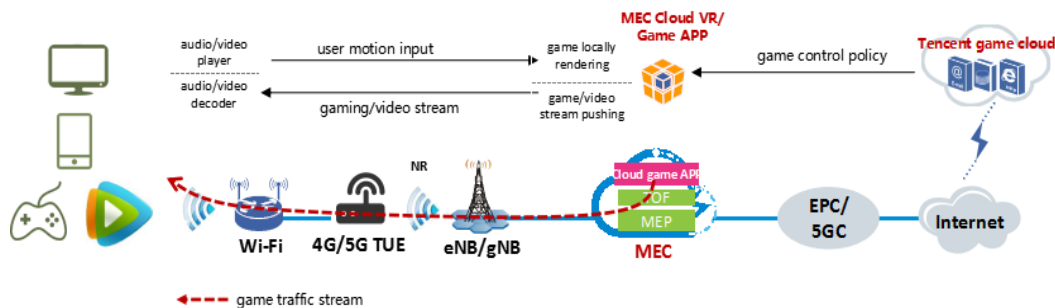



## 7.2 TCP Optimization base on MEC

The goal of TCP (and a TCP optimizer) is to make sure the sender's and the server's in-flight data rate matches the bandwidth delay product (BDP) of the network. The BDP is the mathematical product of the instantaneously available network bandwidth and the network latency.

In many situations, TCP is too conservative and the speed up is too slow, in this case the network might have capacity available right now, but a new TCP flow takes a little while to speed up. This problem arises on all access networks, with varying impact to subscribers. For instance, consider a few packets dropped in the radio network, which causes a TCP server to dramatically slow its transmission; a subscriber on a 3G network might get frustrated that her download drops from 15 Mbps to 7.5 Mbps to less than 4 Mbps to less than 2 Mbps and then slowly climbs back up; a subscriber on an LTE network might be furious that his 60 Mbps drops to 7.5 Mbps... when all-the-while the radio access network (RAN) has capacity to spare.

There are also situations when TCP sends data too fast, and by doing so it inadvertently overwhelms network resources (in particular, the buffers/queues in access network resources). When this situation—called buffer bloat—occurs, it results in a huge spike in latency and has a major negative impact on subscriber quality of experience, particularly for interactive applications that rely on real-time feedback mechanisms.



The TCP optimization functions “TCP acceleration” reduce the above problems (Speed up too slow and Huge spike in latency) improving the custom experience.

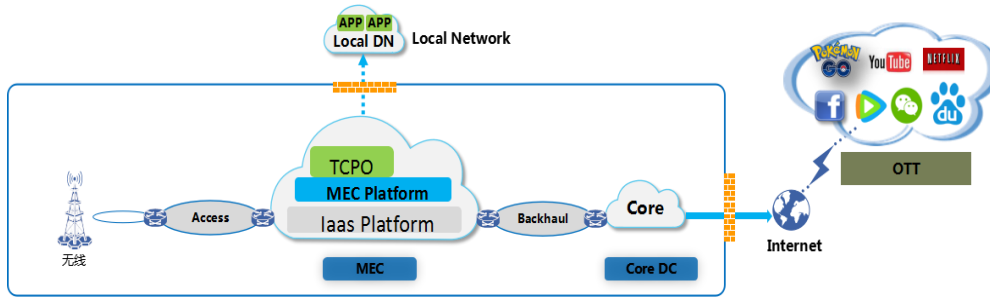

TCP optimization is meant to ensure that TCP isn't a bottleneck in the network, thereby allowing TCP to utilize available bandwidth. Measuring the average TCP transfer speeds with and without TCP acceleration in place is possible to appreciate a significant improvement. See in the figure below result obtained in W3 LAB:

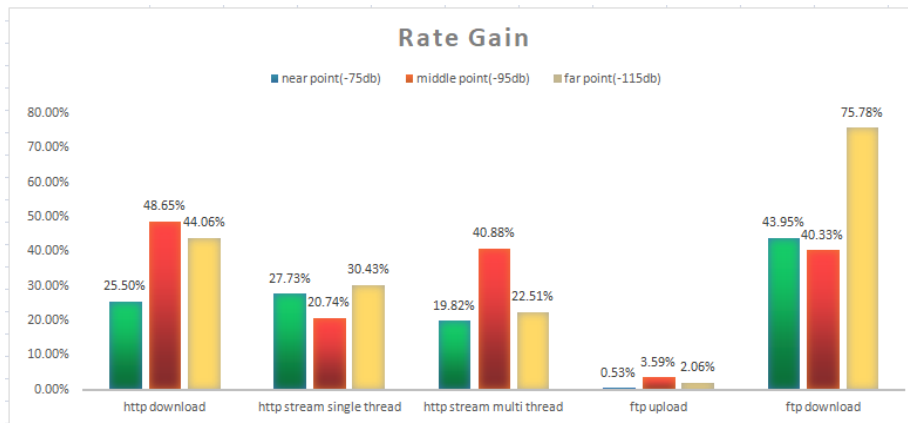

Circumstances in which TCP sends data too fast, overwhelms buffers/queues, and increases effective latency. The high latency is correlated with poor subscriber quality of experience; With the right TCP acceleration solution in place, the effective latency can be reduced to a level approximating the base access network latency.

The Figure below shows the positive impact of TCP acceleration on the latency in a 4G network with TCP acceleration enabled:

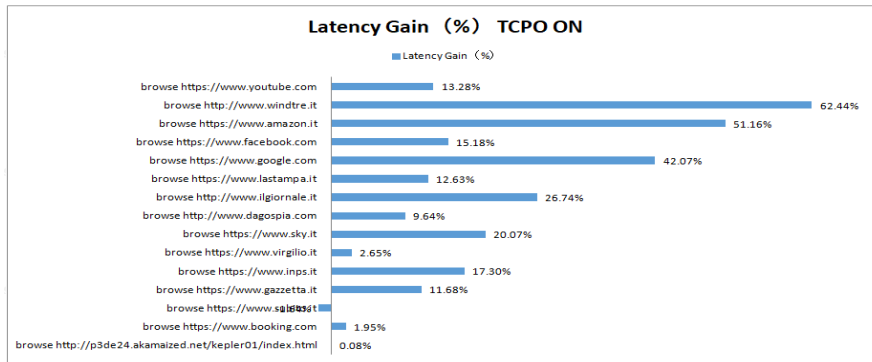

### 7.3 Smart factory base on MEC

In October 2018, based on the nokia vMEC solution, it was successfully deployed and put into trial operation in BMW brilliance factory. In the early stage, it provided mobile office access service, and in the later stage, it will provide BMW plant with wireless video monitoring, production line operation and maintenance inspection, intelligent intercom, indoor navigation, VR live broadcast, intelligent production of industrial robots and other businesses.

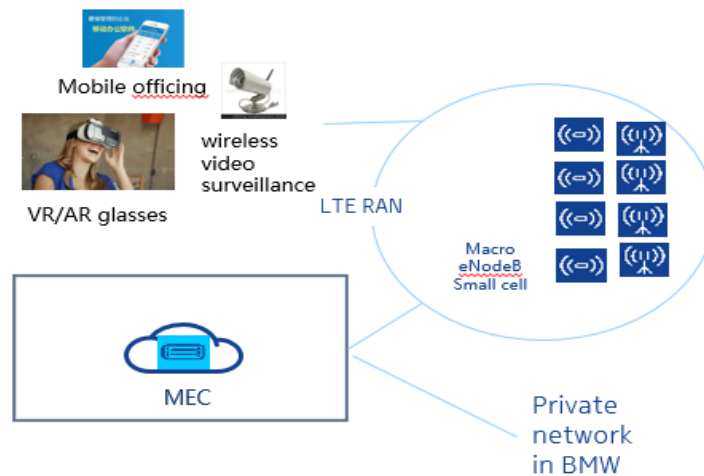



## 7.4 Smart hospital base on MEC

4G + MEC in LTE network based enterprise private network, hospital HIS system as data source, for medical custom terminal hardware carrier, to mobile software for the business to show care and provides a high speed, safe, reliable solutions, fill the ihs and in digital hospital ward "20 meters" information gap between, can make the nurses in the ward hospital information system support anytime and anywhere, to carry out the effective nursing data checking, data collection and transmission, and improve nursing efficiency and quality.

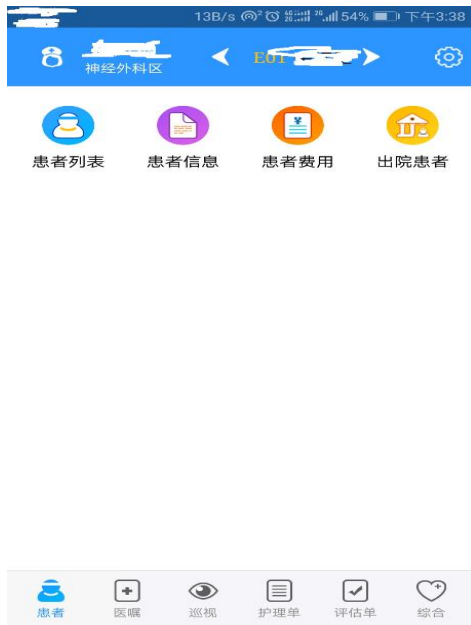

## 7.5 Smart port base on MEC

Ports play a pivotal role in the development of the global economy, and the construction of intelligent ports has become an inevitable choice for all major ports to bear increasingly heavy burdens. The high-definition video surveillance, the AGV automatically guided transport vehicle and the abutment, and other operations have extremely high requirements for delay and stability.



Huawei MEC solution solves the problem of high cost and poor stability of traditional wired and WiFi network solutions by locally deployed GWs, data local offloading, local control, and local operation, to provide a low-latency, high-reliability mobile infrastructure networks in the port. At the same time, as a business integration platform, Huawei MEC solution provides powerful computing capabilities, and can integrate intelligent production management and control system, intelligent image analysis and recognition system, AGV intelligent control system, port office system and so on. To create an efficient, stable and secure network environment for smart ports.

## 7.6 Smart Refinery base on MEC

Zhenhai Refining and Chemical Co., Ltd. is a large holding subsidiary and key enterprise directly under China Petroleum and Chemical Corporation. The smart factory project is a major step in the enterprise information development, it fully uses wireless resources on live networks and applies the Huawei MEC solution to perform local management and local operation of services, including local traffic break out (LBO), local traffic charging and control. This implementation meets real-time and high-bandwidth service requirements for video surveillance, mobile office, and on-site data collection and transmission.

After the project construction is completed, a registered user of the enterprise private

network can access various networks based on customized requirements. The MEC network enables access to both the enterprise private network and public network services, as well as network isolation within the enterprise park.

---

## 8 Summary

In the face of the upcoming 5G era and the convergence of ICT integration, we need to embrace the future with a changing attitude and win the future. Different from the role of the pipeline provider in the 4G era, operators will have more opportunities to expand value-added services in the 5G era and become a comprehensive end-to-end service provider. As a new technology for ICT convergence, edge computing will sink high-bandwidth, low-latency, and localized services to the edge of the network, providing unified telecommunications infrastructure support for solid-mobile convergence, which is critical for operators' digital transformation and industrial structure upgrade.

At present, although standard organizations to industry alliances are actively investing in the development of edge computing technology, how to build a marginal industry ecology requires more open collaborative research and bold industry practices.

Based on the Edge Computing Lab, GTI will work with 5G to create a number of vertical industry partners, starting from vertical industry needs, and deepening cooperation on demand scenarios, solution design, and business models to fully promote the edge. Calculate the prosperity of the industry.

The birth of an emerging technology and ecology requires strong support from the business model behind it. Looking forward to the future, the industry has unlimited expectations and expectations for various application scenarios of the edge business platform. But good wishes must become a reality and require the joint efforts of the entire industry chain. GTI is willing to join hands with more industry partners in the next MEC scale pilot and commercial promotion process to jointly explore the cooperation model of the edge business platform, jointly build a 5G network edge ecosystem, and

comprehensively promote the flourishing of the edge business.