

**GTI**

**Sub-6GHz 5G Device**

**White Paper**

**GTI**

<http://www.gtigroup.org>

# *GTI Sub-6GHz 5G Device*

## *White Paper*



<b>Version:</b>	V3.0
<b>Deliverable Type</b>	<input type="checkbox"/> Procedural Document <input checked="" type="checkbox"/> Working Document
<b>Confidential Level</b>	<input checked="" type="checkbox"/> Open to GTI Operator Members <input checked="" type="checkbox"/> Open to GTI Partners <input type="checkbox"/> Open to Public
<b>Working Group</b>	Terminal WG
<b>Task</b>	
<b>Source members</b>	CMCC, Sprint, Anritsu, Intel, Mediatek, OPPO, Qualcomm, R&S, Samsung, UNISOC, vivo
<b>Support members</b>	
<b>Editor</b>	CMCC, Sprint
<b>Last Edit Date</b>	07-06-2018
<b>Approval Date</b>	

**Confidentiality:** This document may contain information that is confidential and access to this document is restricted to the persons listed in the Confidential Level. This document may not be used, disclosed or reproduced, in whole or in part, without the prior written authorization of GTI, and those so authorized may only use this document for the purpose consistent with the authorization. GTI disclaims any liability for the accuracy or completeness or timeliness of the information contained in this document. The information contained in this document may be subject to change without prior notice.

## Document History

Date	Meeting #	Version #	Revision Contents
10-11-2017	20 <sup>th</sup> GTI Workshop	V1.0	The first version of GTI sub-6GHz 5G Device Whitepaper. The communication functions and performance requirements and key research points of 5G devices are described.
30-01-2018	21 <sup>st</sup> GTI Workshop	V2.0	GTI sub-6GHz 5G Device Whitepaper Update: Align with NSA specs have been completed in 3GPP. Add simulation results and analysis in Demodulation Performance and Power Consumption section.
07-06-2018	22 <sup>nd</sup> GTI Workshop	V3.0	GTI sub-6GHz 5G Device Whitepaper Update: Align with NSA/SA specs have been completed in 3GPP. Add UE Modem Challenges and Solutions for supporting SA/NSA. Update the latest plan and progress of Conformance Test.

## Table of Contents

1	Executive Summary.....	7
2	Abbreviations.....	8
3	Introduction.....	10
4	References.....	10
5	Form Factor of 5G Device.....	12
6	General Description.....	15
6.1	System Description.....	15
6.1.1	Key System Requirements.....	15
6.1.2	Performance requirements.....	16
6.2	Physical Layer Requirements.....	16
6.2.1	Multiple numerologies.....	17
6.2.2	Flexible frame structure.....	18
6.2.3	Bandwidth part configuration and adaptation.....	19
6.2.4	Initial access.....	20
6.2.5	Mobility.....	21
6.2.6	Waveform.....	22
6.2.7	Modulation.....	22
6.2.8	Multiple antenna techniques.....	22
6.2.9	Scheduling and HARQ timing.....	23
6.2.10	Channel coding.....	25
6.3	Upper Layer Requirements.....	25
6.3.1	Control Plane.....	25
6.3.2	User Plane.....	27
6.4	Summary.....	28
7	Multi-Mode Multi-Band.....	29
8	Network Access Capability.....	32
8.1	Connectivity Options in 3GPP.....	32
8.1.1	Standalone NR.....	32
8.1.2	Non-Standalone NR.....	34
8.2	Uplink Strategies for NR deployment.....	37
8.2.1	Uplink strategies for Standalone Operation.....	37
8.2.2	Uplink strategies for Non-Standalone Operation.....	38
8.3	UE Modem Challenges and Solutions for Supporting Standalone and Non-Standalone NR.....	38
8.3.1	UE modem architecture for NR + LTE dual connectivity.....	38
8.3.2	UE modem challenges and solutions for SA.....	41
9	Inter-RAT Interworking.....	42
9.1	NR mobility state transition.....	42
9.2	Inter-System Procedure.....	44
9.2.1	Interworking Procedures with N26 interface.....	45
9.2.2	Interworking Procedures without N26 interface.....	45
10	Voice Solution.....	46

10.1	Potential solutions.....	46
10.2	Summary .....	48
11	RF Performance.....	49
11.1	High Power UE.....	49
11.1.1	Motivation .....	49
11.1.2	3GPP Status .....	49
11.1.3	TX Front-end Status and Architecture for HPUE.....	49
11.1.4	Consideration on Thermal for HPUE.....	50
11.1.5	Consideration on SAR for HPUE.....	51
11.2	In-Device Interference.....	52
11.3	SUL.....	56
11.4	LTE and 5G NR RF path co-banding .....	57
11.4.1	Concept and Architecture of RF Path Co-banding .....	57
11.4.2	System-level Challenges .....	58
11.4.3	Way Forward on standalone support .....	60
11.4.4	Co-banding with simultaneous operation .....	60
12	Demodulation Performance.....	61
12.1	High Speed Train Scenarios.....	61
12.2	UE Speed and DMRS Density.....	63
13	Power Consumption.....	66
13.1	Introduction .....	66
13.2	Key scenarios and performance metrics.....	66
13.2.1	Maximum throughput .....	67
13.2.2	The power vs latency trade-off .....	67
13.2.3	Achieving power efficient VoNR and ViNR .....	67
13.2.4	TDD spectrum and NR UE power consumption .....	68
13.2.5	Scheduling implications.....	68
13.3	Power scaling from LTE to NR .....	68
13.3.1	Example power breakdown for an LTE UE .....	69
13.3.2	A simple power model for the NR UE.....	71
13.3.3	RF front end power.....	71
13.3.4	Transceiver subsystem power .....	73
13.3.5	Baseband processing power.....	75
13.3.6	Standalone NR UE power consumption .....	76
13.4	Managing UE power efficiently.....	77
13.4.1	Bandwidth part adaptation .....	78
13.4.2	Cross-slot scheduling.....	79
13.4.3	Power vs data rate.....	80
13.4.4	Overttemperature protection.....	81
13.4.5	Periodic PDCCH monitoring.....	81
13.5	Implications for NR UEs.....	81
13.5.1	Better efficiency, but higher peak power.....	81
13.5.2	Standalone vs Non-standalone.....	82
13.5.3	Downlink processing may use more power than uplink transmit.....	82

---

13.5.4	Maintaining efficiency at low data rates .....	82
14	Test Requirements .....	83
14.1	Test areas for 5G sub-6G and challenges .....	83
14.1.1	Test challenges.....	83
14.1.2	Requirement for test equipment.....	84
14.2	Device test cycle and test solutions .....	84
14.3	3GPP RAN5 Conformance Test .....	86
14.3.1	Target dates .....	86
14.3.2	Progress to-date .....	87
14.4	Risks.....	87
15	Other Aspect .....	88

# 1 Executive Summary

In recent years, 4G has profoundly changed our daily life, and stimulate people's desire for higher performance and better user experience for more innovative services and applications. Towards 2020, the mobile communication will rapidly penetrate to more and more elements of the human's daily life and the society's operation, which will create the opportunities for the mobile industry and other vertical industries. With the new capabilities, e.g. extremely high data rate, extremely low latency and extremely high reliability, massive connection and traffic density, the 5th generation mobile communication technology (5G) will shine a light on the great change on both our daily life and the whole society's operation.

Targeting for commercial launch of 5G in 2020, the global telecommunication operators, network, chipset and device vendors, test instrument manufacturers and solution providers are deeply involved to promote end-to-end maturity of standard and industry. 5G technology development and trial activities comprise some main phases, such as Key technology feasibility validation, Prototype development and trials, Pre-commercial product development, Lab tests and Field trials for pre-commercial and commercial product, Commercial Launch and so on.

In the face of 5G services and market trends, there are many key capabilities and performance indicators for 5G network, base station and device. And there are also many challenges for 5G Device Design and Implementation, so 5G Device Whitepaper is necessary to define the technical requirements for 5G Device and direct the research and analysis on key points. GTI encourages the industry partners to participate the 5G activities and work together to make contributions to the 5G Device White Paper.

## 2 Abbreviations

Abbreviation	Explanation
2/3G	The 2/3rd Generation Telecommunication
3GPP	The 3rd Generation Partnership Project
4G	The 4th Generation Telecommunication
5G	The 5th Generation Telecommunication Technology
AR	Augmented Reality
CC	Component Carrier
CP	Control Plane
CPE	Customer Premise Equipment
DC	Dual Connectivity
eMBB	Enhanced Mobile Broadband
gNB	NR node
GP	Guard Period
IPv4	Internet Protocol version 4
IPv6	Internet Protocol version 6
LDPC	Low Density Parity Check
MAC	Medium Access Control
MCG	Master Cell Group
ME	Mobile Equipment
MIMO	Multiple-Input Multiple-Output
mMTC	Massive Machine Type Communication
mmWave	Millimeter Wave
MN	Master Node
MR	Mixed Reality
MU-MIMO	Multi-User MIMO
NAS	Non Access Stratum
NG Core	Next Generation Core Network
NR	New Radio
NSA	Non-Standalone
OFDM	Orthogonal Frequency Division Multiplexing
PDCP	Packet Data Convergence Protocol
PDN	Packet Data Network
PLMN	Public Land Mobile Network



PoC	Proof of Concept
RLC	Radio Link Control
RRC	Radio Resource Control
SA	Standalone
SCG	Secondary Cell Group
SN	Secondary Node
SU-MIMO	Single-User MIMO
UE	User Equipment
UP	User Plane
URLLC	Ultra-Reliable and Low Latency Communications
VR	Virtual Reality

### 3 Introduction

Targeting for the 5G industrialization, this White Paper is necessary to facilitate the development of 5G chipset/ device and the corresponding test instruments. This document targets enhanced Mobile Broadband (eMBB) scenario for Sub-6GHz 5G pre-commercial and commercial products, which is conducted to be the technical references for the development of chipset/ device and the basis for the 5G pre-commercial and commercial products specs.

Form Factor of 5G Device, the communication functions and performance requirements of 5G devices are described in this White Paper. And it focus on discussion about the key research points of 5G Device, including Multi-Mode Multi-Band, Network Access Capability, Inter-working and Voice Solutions, RF Requirements, Demodulation Performance, Power Consumption and Device Testing Requirements.

5G device will follow 3GPP 5G NR Release 15 and later releases. This document will be updated according to the progress of 3GPP 5G NR standardization and the findings from the development and trials.

---

### 4 References

The following documents contain provisions which, through reference in this text, constitute provisions of the present document.

- [1] 3GPP, TS 38.211, NR; Physical channels and modulation, v15.0.0
- [2] 3GPP, TS 38.212, NR; Multiplexing and channel coding, v15.0.0
- [3] 3GPP, TS 38.213, NR; Physical layer procedures for control, v15.0.0
- [4] 3GPP, TS 38.214, NR; Physical layer procedures for data, v15.0.0
- [5] 3GPP, TS 37.340, NR; Multi-connectivity Stage 2, v15.0.0
- [6] 3GPP, TS 38.300, NR; Overall description; Stage-2, v15.0.0
- [7] 3GPP, TS 23.501, NR; System Architecture for the 5G System Stage-2, v15.0.0
- [8] 3GPP, TR 36.824, V11.0.0
- [9] 3GPP, R4-1700977, Discussion on High power UE for 3.5GHz 5G NR, CMCC
- [10] 3GPP, R4-1706068, WF on high power UE for 3.5GHz, CMCC, Skyworks, Qorvo, Broadcom, MediaTek, Vodafone, CATT, Huawei, HiSilicon, ZTE
- [11] 3GPP, RP-142307, New SI proposal: Performance enhancements for high speed scenario, NTT DOCOMO, INC., Huawei, HiSilicon, Dec. 2014
- [12] 3GPP, R4-150554, High speed train scenarios, CMCC, Feb. 2015
- [13] 3GPP, R4-166805, Way forward on UE performance enhancement under SFN scenario, Huawei, HiSilicon, NTT DOCOMO, Qualcomm Incorporated, MediaTek Inc. , CMCC, CATT, ZTE, Ericsson

- [14] 3GPP, TS36.101, Annex B, Propagation Conditions, v14.4
- [15] 3GPP, R4-157700, Enhance UE performance under SFN scenario, Huawei
- [16] 3GPP, R4-165823, View on the reference receiver for high speed train enhancement, MediaTek
- [17] 3GPP, TS38.211, Section 7.4.1, Reference Signals, v2.00
- [18] 3GPP, R2-1708011 Thermal mitigation in NR UEs, Mediatek
- [19] 3GPP, R1-1710838 Cross-slot scheduling for UE power saving, Mediatek
- [20] M. Lauridsen, P. Mogensen, and L. Noël. Empirical LTE Smartphone Power Model with DRX Operation for System Level Simulations, IEEE 78th Vehicular Technology Conference, Sep 2013.
- [21] B. Murmann, ADC Performance Survey 1997-2017, [Online]. Available: <http://web.stanford.edu/~murmman/adcsurvey.html>.
- [22] 3GPP, R1-167531 Area, power and latency comparison for NR high throughput decoder, Qualcomm
- [23] A.Stillmaker and B.Baas, Scaling equations for the accurate prediction of CMOS device performance from 180nm to 7nm Integration, the VLSI Journal June 2017
- [24] 3GPP, R1-1612067 Evaluation of frame structure design for UE Power Consumption, Qualcomm
- [25] 3GPP, R5-176537 WP UE Conformance Test Aspects - 5G system with NR and LTE, Ericsson

## 5 Form Factor of 5G Device

There are three main classes of new 5G applications: Extreme Mobile Broadband (eMBB), Ultra-Reliable Low Latency Communications (URLLC) and Massive Machine Type Communication (mMTC). mMTC can mostly be fulfilled by modification and optimization of existing cellular technologies (e.g. NB-IoT), however URLLC and eMBB require new technologies to break new bandwidth and latency boundaries. These will unlock new, potential applications and services that require 5G infrastructure. In this white paper we are focused on potential use cases and applications of eMBB devices, potential use of URLLC is also discussed.

5G infrastructure has significant benefits for a number of applications that are already limited in some capacity by existing 4G services. However this is only the beginning, as every generational shift that grants more capacity and speed always grants unforeseen and unpredictable applications that will only be realized later.

Known applications that will benefit demand high bandwidth and/ or ultra-low latency include

1. Virtual, mixed and augmented reality
2. Autonomous driving
3. Infotainment services for public and private transportation
4. 360-degree, 4K/ 8K resolution live entertainment and sports
5. Alternative to landline fiber services
6. Game-streaming services
7. Thin/ zero client for mobile devices

Brief introduction on these applications are provided below, for further details the analysis of innovative services can be refer to the “GTI Research Report of 5G New Device Type”:

### **1. Augmented Reality (AR), Mixed Reality (MR) and Virtual Reality (VR) devices**

One of the biggest upcoming technological revolutions is AR, MR or VR devices. Each has its own unique applications and opportunities, but all are still in their infancy and currently range from proof-of-concept devices to immature platforms. 5G eMMB can help unlock further advancements to yield new opportunities.

As smartphone performance increases, they are transforming into devices that can be used with VR/ AR headsets. Currently, Google’s Tango technology uses a Visual Positioning Service<sup>1</sup> (VPS) for in-door navigation, but it relies heavily on local Wi-Fi networks to define its location and the spaces it maps out. Using 5G technologies will enable more consistent signal coverage allowing VPS to be mapped via a combination of camera(s), cellular location and GPS.

Generally speaking, AR/ MR/ VR are all data rate hungry, which translates to power and battery limitations in smartphones and wearable devices (for example: Samsung Gear VR or Microsoft Hololens). A revolutionary 5G use-case could instead offload the AR/ MR/ VR sensor inputs and graphics rendering to a Cloud server, which would require only a much simpler, low power user-device that acts only as sensor recorder, 5G cellular transmitter and video decoder. This design would significantly lower the cost of ownership, enabling a much greater market potential and service-style models based on Cloud-server use time. However to enable Cloud-based processing without upsetting user experience, 5G eMMB with lower latency will be required as they provide the necessary streaming bandwidth and low reaction time.

## **2. Autonomous driving**

Autonomous driving will greatly depend on wireless connectivity. Enabling vehicles to communicate with each others could result in considerably more efficient and safer use of existing road infrastructure. If all the vehicles on a road were connected to a reliable network incorporating a traffic management system, they could potentially travel at much higher speeds and within greater proximity of each other without risk of accident. Potential dangers spotted by the increasing number of vehicular sensors could immediately be relayed to other vehicles in the vicinity.

While such systems would not require very high data bandwidth, providing a reliable infrastructure with a low response time would be crucial for their safe operation. Such applications require the millisecond-level response addressed in the 5G specification.

## **3. Infotainment services for public and private transport**

While current personal media needs are mostly being serviced by smartphones and tablets, private vehicles increasingly have infotainment functions built in as natural extension to the legacy of radio, CD and DVD. While air travel has embraced in-seat infotainment for many years and subscription based services for private vehicles is gaining traction, public ground transportation services could also provide in-seat infotainment as a source of additional revenue. Streaming data in both these scenarios would require the multi-Gigabit bandwidth addressed in the 5G specification. Bandwidth requirements are dictated not only by the number of people serviced (5 people per car, 50 per coach or 500 per train for example) but also the quality of streaming media: Full HD, UltraHD 4K and future 8K (with respective quality increments in digital audio as well).

## **4. 360-degree, or 4K/ 8K resolution live entertainment and sports**

Major sporting and entertainment events are both big value investments and have historic precedent. The potential market is very significant, with regular events in the hundreds of millions of viewers: the 2017 American Super Bowl had 111.3 million people watching, F1 motorsport has 425 million fans globally, and Manchester United soccer club alone has over 650 million global fans.

They are also frequently the perfect opportunity by the host to showcase the latest technologies. For example, the Tokyo Olympics is already set to become the first sporting

event to broadcast in 8K, and one of the first to have 5G network coverage.

Smartphones displays are moving towards ever higher resolutions with HDR quality (for example: Sony Xperia XZ Premium, LG G6, Samsung Galaxy S8), with video streaming services such as Netflix following as sufficient devices reach the hands of consumers. Some operator has already committed to the 2020 Olympics streamed over 5G to VR devices, which will let users feel like they are actually in the stadium with the athletes.

4K/ 8K broadcasting and 360-degree drone-enabled live video streaming requires extreme levels of bandwidth only 5G technologies can service, with multi-Gigabit throughput sufficient to make such systems a reality.

## **5. Alternative to landline fiber services**

eMMB wireless can be an attractive alternative to fiber roll-out. Fiber roll-out can incur a significant cost, with a long roll-out time, or is simply unviable due to environmental, regulatory or other economic factors such as small subscriber numbers (small/ remote towns and villages) or factors such as fixed infrastructure where it's too difficult to retrofit, such as tall, inner-city apartment blocks or commercial buildings.

Since there is already ongoing investment in worldwide cellular services to increase coverage and reliability, the use 5G eMMB could provide an alternative backbone to fiber, giving these locations fast connectivity for home and office use; enabled by low-cost, fixed antenna to the apartment or as a service for the whole building.

High-bandwidth and reliable internet services can allow for more efficient remote-working and inter-office collaboration tools; which is an attractive investment for local or national governments looking to stimulate business and job opportunities outside of cities.

## **6. Gaming as a Service (GAAS)**

For consumer devices, video games are a rare use case of high power computing. The video game industry has consistently pushed of performance for premium PCs, games consoles and premium mobile products.

Game streaming services (GAAS), however, moves the core processing onus from the user device into the Cloud. The user input/ action is recorded and sent to the remote Cloud-server, where the game environment is rendered and only the display and audio output – essentially a livestream video feed – is sent to the user device. This means the user device requires only state of the art connectivity and simple AV decoding.

This type of service model is very attractive to many game publishers, infrastructure operators and users as it greatly lowers the ownership cost to a regular service fee, but previous attempts of services such as Sony PSNow and Nvidia GeForce GRID have only achieved limited success. A user experience that mirrors a local gaming device has not yet been met, often due to latency and bandwidth limitations even when using fixed line connections.

5G eMMB with low latency will meet the requirements of these services, finally unlocking

their market potential.

### **7. Thin/ zero client for mobile devices**

Thin or zero clients have specific advantages in device cost and data security. With little to no locally stored user files, corporate devices can be very efficiently managed and monitored. 5G eMMB could potentially provide users their apps and data, or even an entire OS state, every-time they turned on their device with little delay.

This is attractive if data-security and corporate device control is an essential consideration, as lost or stolen devices are simply locked out of the network with no local data risk.

Based on the envision of potential 5G eMBB scenario described above, the main form factor of 5G device will be similar as smart handheld device today because consumers have been used to such kind of device and establish their daily behavior. For other scenarios, there will be more different devices such as module used to provide communication access service for vertical industry and consumer electronics terminal.

---

## **6 General Description**

3GPP has been working on an accelerated path of developing 5G NR specifications. The Initial work is concentrated on NSA (Non-standalone) mode, followed by Standalone (SA) mode soon after. NSA is expected to be an intermediate step for smooth transition of existing networks to 5G. It is also expected that LTE Advanced pro deployments are going to be around for many coming years and hence could benefit from NSA. However, some operators may also choose to directly deploy a dedicated network for 5G services using Standalone mode. It is an end state to reap full potential of 5G network.

With this in mind, GTI sub-6GHz device is expected to support both NSA and SA mode of operation. NSA mode relies on Dual connectivity for its operation while SA may involve Inter-RAT mobility management. This section will provide high level guidelines for supporting NR in SA mode as well as NR-LTE in NSA mode.

### **6.1 System Description**

This subsection will focus on high level NR system requirements to be supported in initial 5G UE for eMBB use case.

#### **6.1.1 Key System Requirements**

This subsection will provide key system requirements for 5G NR device support which may be common among GTI operators.

- Frequency bands and System bandwidth:

Table 6-1 5G NR Band list

RAT	Band	Max BW for 15kHz	Max BW for 30kHz	Max BW for 60kHz
NR	Band n77 (3.3 GHz ~4.2GHz)	50MHz	100MHz	100MHz
	Band n78 (3.3 GHz ~3.8GHz)	50MHz	100MHz	100MHz
	Band n79 (4.4GHz~5GHz)	50MHz	100MHz	100MHz
	Band n1	20MHz	20MHz	20MHz
	Band n3	30MHz	30MHz	30MHz
	Band n8	20MHz	20MHz	NA
	Band n41	50MHz	100MHz	100MHz

NOTE 1: Table 6-1 will be updated according to NR bands and Bandwidths defined in 3GPP and operators' deployment.

NOTE 2: The actual system bandwidth for one operator depends on how much 5G frequency is allocated for this operator.

- MIMO configurations:
  - UL: 2 layers required, 4 layers recommended
  - DL: 4 layers required, 8 layers recommended

## 6.1.2 Performance requirements

- Latency requirements
  - Control plane:  $\leq 10$ ms
  - User plane:  $\leq 4$ ms for one way
- Single user peak data rate

The recommended UL and DL single user peak data rates for different MIMO layers are given below.

- DL peak data rate for 4 layers:  $\geq 1.3$ Gbps
- DL peak data rate for 8 layers:  $\geq 2$ Gbps
- UL peak data rate for 2 layers:  $\geq 175$ Mbps
- UL peak data rate for 4 layers:  $\geq 350$ Mbps

Configurations: 100MHz BW: 70% DL; Uplink 64QAM; DL 256QAM for 4 layers and 64QAM for 8 layers.

## 6.2 Physical Layer Requirements

For 5G Devices in eMBB usage scenario, key physical layer characteristics have been well



studied in the NR study item in 3GPP Release 14 and are now being standardized in NR work item in Release 15. In this subsection, we briefly illustrate the key requirements on the agreed design, from the UE perspective.

## 6.2.1 Multiple numerologies

- A numerology is defined by sub-carrier spacing and CP overhead and multiple numerologies should be supported in NR. For sub-6GHz, the UE should support the following features:
  - Available subcarrier spacing values include 15 KHz, 30 KHz and 60 KHz. The values are configured by gNB and notified to the devices. 30 KHz subcarrier spacing is important to support large channel BW of 100MHz (e.g. 3.5 GHz). In the band lower than 3.5 GHz such as n41, 15 KHz should be supported. 60 KHz for data channel may be also required in supporting some high speed and low latency scenarios.
  - All numerologies with 15 kHz and larger subcarrier spacing, regardless of CP overhead, align on symbol boundaries every 0.5ms in NR carrier.

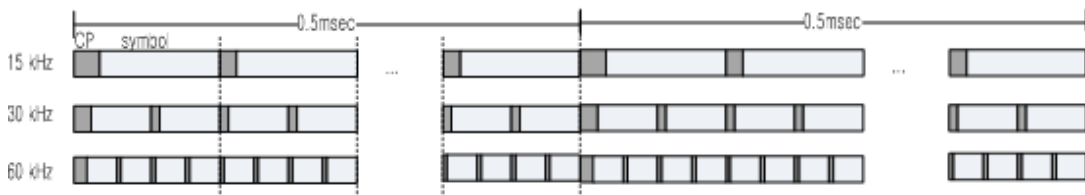

Figure 6-1 Illustration of the symbol alignment

More specifically, for the normal CP family, the following is adopted.

- For subcarrier spacing of  $15 \text{ kHz} * 2^\mu$  ( $\mu=0,1,2$ ),
  - Each symbol length (including CP) of 15 kHz subcarrier spacing equals the sum of the corresponding  $2^\mu$  symbols of the scaled subcarrier spacing.
  - Other than the first OFDM symbol in every 0.5ms, all OFDM symbols within 0.5ms have the same size.
  - The first OFDM symbol in 0.5ms is longer by 16Ts (where Ts is the time unit assuming 15 kHz and FFT size of 2048) compared to other OFDM symbols.

Normal CP can be used with any numerology and the extended CP value will be only one in given subcarrier spacing. LTE scaled extended CP is supported at least for 60 kHz subcarrier spacing in Rel-15. The CP type can be semi-statically configured with UE-specific signaling. UE supporting the extended CP may depend on UE type/ capability.

- In addition to the aforementioned time-domain characteristics, the following frequency domain characteristics are further adopted.

- Assuming the subcarriers in a PRB are numbered from 0 to 11, for a given subcarrier spacing  $F_0$ , subcarrier 0 always coincide with a subcarrier 0 of all subcarrier spacing of order less than  $F_0$ .

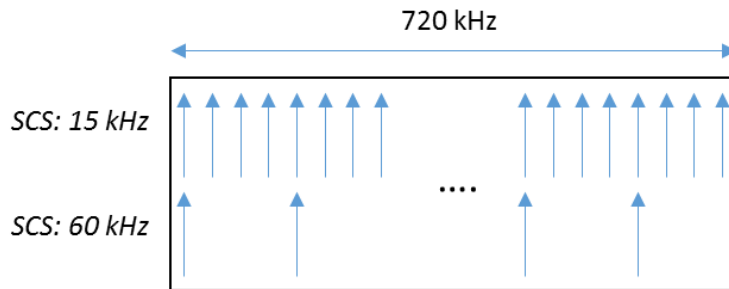

Figure 6-2 Illustration of the subcarrier alignment within one RB of 60kHz numerology

### 6.2.2 Flexible frame structure

In NR, a frame consists of 10 subframe with length of 10ms and each subframe duration is fixed to 1ms.

A slot is defined as 14 OFDM symbols for the same subcarrier spacing of up to 60kHz with normal CP and 12 OFDM symbols for at least 60kHz with extended CP. Table 6-2 and Table 6-3 illustrate the values of number of OFDM symbols per slot, the number of slot per frame and the number of slots per subframe for normal CP and extended CP, respectively. NR UE should support all the slot configurations in Table 6-2 and Table 6-3.

Table 6-2 Number of OFDM symbols per slot,  $N_{\text{slot}}^{\text{slot}}$ , for normal cyclic prefix.

$\mu$	$N_{\text{slot}}^{\text{slot}}$	$N_{\text{slot}}^{\text{frame}, \mu}$	$N_{\text{slot}}^{\text{subframe}, \mu}$
0	14	10	1
1	14	20	2
2	14	40	4

Table 6-3 Number of OFDM symbols per slot,  $N_{\text{slot}}^{\text{slot}}$ , for extended cyclic prefix.

$\mu$	$N_{\text{slot}}^{\text{slot}}$	$N_{\text{slot}}^{\text{frame}, \mu}$	$N_{\text{slot}}^{\text{subframe}, \mu}$
2	12	40	4

NR UE should support the slot format that a slot can contain all downlink, all uplink, or at least one downlink part and at least one uplink part. Slot aggregation should also be supported, i.e., data transmission can be scheduled to span one or multiple slots.

In NR, the aforementioned flexible slot format can be configured to a UE by cell-specific and/or UE-specific higher layer signaling in a semi-static DL/ UL assignment manner, or by

dynamically signaling via DCI in group-common PDCCH (GC-PDCCH). When the dynamic signaling is configured, a UE should monitor GC-PDCCH which carries dynamic slot format indication (SFI).

### 6.2.3 Bandwidth part configuration and adaptation

- Bandwidth part properties include numerology (SCS, CP type), frequency location (e.g. the starting PRB), and bandwidth (e.g. number of PRBs), etc.
- An initial active DL BWP is defined by a location and number of contiguous PRBs, a subcarrier spacing, and a cyclic prefix, for the control resource set for Type0-PDCCH common search space. For operation on the primary cell, a UE is provided by higher layer parameter *initialUplinkBWP* an initial UL BWP for a random access procedure.
- A UE can be configured with up to 4 carrier bandwidth parts in the downlink with a single downlink carrier bandwidth part being active at a given time. The UE is not expected to receive PDSCH, PDCCH, or CSI-RS (except for RRM) outside the active bandwidth part.
- A UE can be configured with up to 4 carrier bandwidth parts in the uplink with a single uplink carrier bandwidth part being active at a given time. If a UE is configured with a supplementary uplink, the UE can in addition be configured with up to 4 carrier bandwidth parts in the supplementary uplink with a single bandwidth part being active at a given time. The UE shall not transmit PUSCH, PUCCH or SRS outside the active bandwidth part.
- For unpaired spectrum, The UE may assume that two bandwidth parts with the same index *i* are paired.
- A UE can be provided by higher layer parameter *defaultDownlinkBWP-Id* a default DL BWP among the configured DL BWPs. If a UE is not provided a default DL BWP by higher layer parameter *defaultDownlinkBWP-Id*, the default BWP is the initial active DL BWP.
- An active BWP among configured ones can be dynamically switched. For example, a UE may receive DCI which indicates switching of active BWP starting from the corresponding PDSCH/ PUSCH. In addition to this, timer-based active BWP switching is also supported in which a UE is required to fallback to default BWP when certain amount of time is passed with continuous inactivity on a current active BWP.
  - This type of active BWP switching can be particularly useful for UE power saving. For example, a UE may be configured in narrow BWP for PDCCH monitoring while being indicated by DCI for PDSCH reception/ PUSCH transmission to switch to wide BWP.

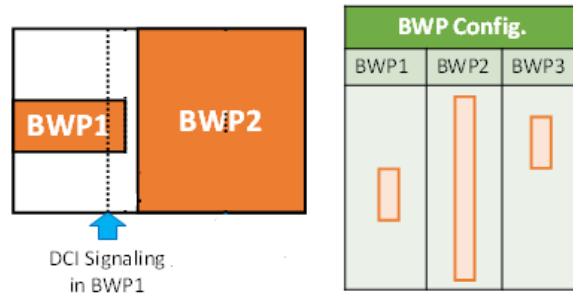

Figure 6-3 Illustration of DCI-based active BWP switching

### 6.2.4 Initial access

- NR UE should support synchronization on time and frequency and the detection of the physical cell IDs from 1008 candidates. Besides, NR UE should support the detection of the SS/ PBCH block under different numerologies and time locations in various frequency carriers and bandwidth configurations. For Sub-6GHz, 15kHz and 30kHz are allowed for SCS of SS/ PBCH block. There are several challenging aspects in detecting SS/ PBCH block as mentioned below, and NR UE should be able to handle these challenges.
  - In LTE, SS/ PBCH is periodic whose period is known to a UE. In NR, while SS burst set is periodic whose period is assumed to be 20ms by a UE during initial access, there can be multiple SS/ PBCH blocks (4 or 8 in sub-6GHz) within each burst set which are not necessarily periodic. As seen in the figure below for 14 (28, respectively) OFDM symbols for 15kHz (30kHz, respectively) SCS, SS/ PBCH block which comprises 4 OFDM symbols is not periodic especially for 30kHz case. In addition to this, not all SS/ PBCH block candidate locations are guaranteed to transmit valid signal.

15kHz SCS	0	1	2	3	4	5	6	7	8	9	10	11	12	13
30kHz SCS (1 <sup>st</sup> mapping pattern)	0	1	2	3	4	5	6	7	8	9	10	11	12	13
30kHz SCS (2 <sup>nd</sup> mapping pattern)	0	1	2	3	4	5	6	7	8	9	10	11	12	13

Figure 6- 4 Illustration of SS/PBCH block allocation in time-domain

- 3 or 2 LSB's of SS/ PBCH block within each burst set which a UE needs to identify during initial access is carried by PBCH DMRS scrambling sequence, and this requires the corresponding blind detection.
- For some bands, dual SCS for SSB are supported. Thus there would be uncertainty on SS/PBCH SCS between 15kHz and 30kHz.
- Mapping of SS/ PBCH block is described in the figure below. It can be seen that PSS is mapped in the first OFDM symbol, and this creates challenge on AGC operation for PSS detection since there may not be useful signal before PSS which can be used to set proper gain level.

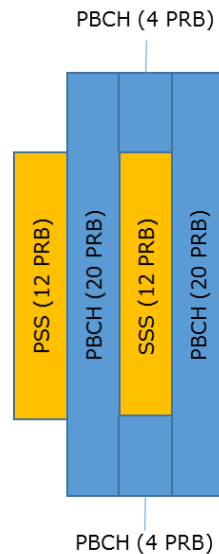

Figure 6-5 Illustration of SS/PBCH block mapping

- In frequency-domain, unlike LTE whose SS/PBCH is located at the center of system bandwidth, SS/ PBCH block in NR can be flexibly located on sync-rasters that are not necessarily on the center of the system bandwidth. Hence, NR UE would need to be careful if it makes any assumption on spectral shape around SS/ PBCH block.
- NR UE should support obtaining the essential minimum system information, including at least SFN, SS block time index and configuration information of PDCCH for RMSI (Remaining minimum System Information) from PBCH.
  - In NR, detected SS/ PBCH block may not have an associated RMSI, i.e., the SS/PBCH block is not the cell-defining one, and NR UE should be prepared to continue SS/ PBCH block detection at different frequency location with the corresponding indication on PBCH.
- NR UE should support the RMSI with flexible numerology. Numerology as well as frequency location for RMSI can be different from those for SS/ PBCH block.

## 6.2.5 Mobility

- NR UE should support various DL-signal measurements at least based on RSRP or RSRQ for mobility purpose for intra-frequency, inter-frequency etc. For IDLE/inactive mode, SS/ PBCH block is used for measurement while CSI-RS can also be used for Connected mode. For measurement based on SS/PBCH block, a UE can be configured SS block based RRM measurement timing configuration (SMTC) during which a UE attempts measurement.
- SS/PBCH block as well as CSI-RS may only have sporadic availability, and NR UE should be able to handle potential challenge in scheduling intra-frequency measurement.

- A similar measurement scheduling challenge happens for inter-frequency measurement when SMTC and GAP are not aligned for multiple frequencies.
- NR UE can be configured to report SS/ PBCH block index during measurement which is carried by PBCH DMRS scrambling sequence in sub-6GHz. Hence, NR UE should attempt the corresponding blind identification during measurement regardless of utilization of PBCH DMRS for measurement.

## 6.2.6 Waveform

- NR UE should support CP-OFDM-based waveform in both DL and UL. With CP-OFDM based waveform, spectral utilization should be equal or greater than that of LTE (90% for LTE) which is defined as transmission bandwidth configuration/ channel bandwidth \* 100%. Transparent spectral confinement technique(s) (e.g. filtering, windowing, etc.) for a waveform can be used at the UE side in either UL transmission or DL reception. CP-OFDM waveform can be used for single-stream and multi-stream transmissions.
  - In NR, there is no dedicated DC subcarrier for CP-OFDM, and all subcarriers within channel can be utilized for valid transmission.
- NR UE should also support DFT-S-OFDM based waveform for uplink transmission. DFT-S-OFDM is limited to a single stream transmissions.
- NR UE should support the switching between CP-OFDM and DFT-S-OFDM in UL, following the network configuration.

## 6.2.7 Modulation

- For NR DL, UE should have the capability to demodulate the symbols with constellation mapping of QPSK, 16QAM, 64QAM and 256QAM.
- For NR UL, UE should have the capability of modulate the information bits with  $\pi/2$  BPSK (only applicable to DFT-s-OFDM), QPSK, 16QAM, 64QAM and 256QAM mapping.

## 6.2.8 Multiple antenna techniques

- UE should support 4 layer DL transmission and 2 layer UL transmission, and consider to support up to 8 layer DL transmission and up to 4 layer UL transmission.
- NR UE should support DL DMRS based spatial multiplexing (SU-MIMO/ MU-MIMO).
- NR UE should support the channel estimation for demodulation for at least 8 orthogonal DL DMRS ports. There are several major challenges arising from NR DMRS design, and NR UE should be able to handle these challenges.

- Regarding PDCSH PRB-bundling in frequency domain, NR allows flexible configuration which can also be dynamically indicated by DCI. The configuration includes PRB bundling size of the whole scheduled resources.
- The number of front-loaded DMRS symbols in each slot can also be dynamically indicated by DCI. A UE should be able to handle such dynamic indication in channel estimation.
- In NR, FD-OCC is introduced to multiplex multiple DMRS ports as seen in figure below (config type 2). In addition to this, CS (cyclic shift)-type mapping is additionally introduced (config type 1).

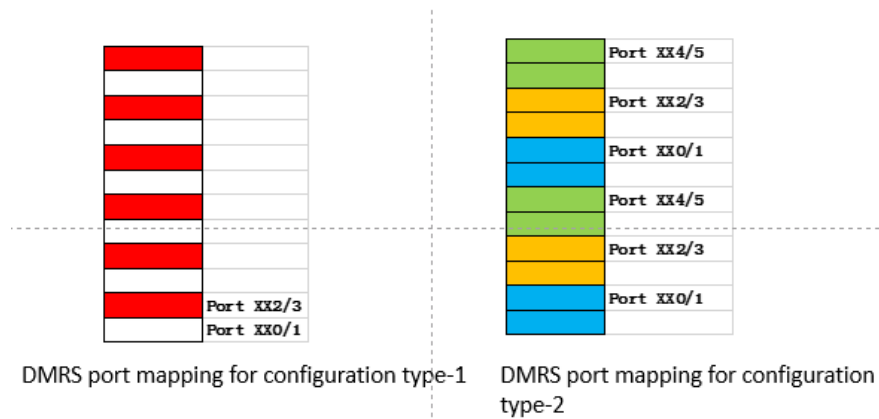

Figure 6-6 Illustration of DMRS port mapping

- In NR, there is no broadcast reference signal which is present in every DL slot, and a UE needs to maintain frequency/ time/ gain tracking loop as well as estimation of channel statistics (delay and Doppler spread etc.) without such consistent signal. To overcome the opportunistic nature of DMRS, CSI-RS for tracking can be configured while CSI-RS and SS may additionally be utilized.
- NR UE should support aperiodic/semi-persistent/periodic CSI-RS/IMR and CSI reporting with up to 32 CSI-RS ports.
  - While NR CSI reporting design closely resembles LTE (e)FD-MIMO framework, NZP-CSI-RS-based IMR is newly introduced in NR. A UE with supporting NZP-CSI-RS-based IMR can acknowledge interference layer at each configured port if reporting such UE capability as well as other interference signal on RE's for IMR.
- NR UE should support SRS transmission with antenna switching over multiple Tx antennas and the UE can report its switching capability to the gNB.

### 6.2.9 Scheduling and HARQ timing

- NR UE should support symbol-level PDCCH monitoring, i.e. starting symbol of a PDCCH search space set within a slot can be configured.

- NR UE should support symbol-level scheduling, i.e. starting symbol and duration of a PDSCH, a PUSCH or a PUCCH can be dynamically indicated.
- NR UE should support PDSCH processing time described in the table below for slot-based scheduling including CA without cross-carrier scheduling and with single numerology for PDCCH and PDSCH. PDSCH processing time is defined as the number of OFDM symbols between the end of PDSCH transmission and the start of HARQ-ACK transmission.

Table 6-4 NR baseline HARQ processing time

SCS	PDSCH processing time [symbols]	
	No additional PDSCH DM-RS configured	Additional PDSCH DM-RS configured
15kHz	8	13
30kHz	10	13
60kHz	17	20

- NR UE should support DL assignment and the scheduled DL data in the same slot.
- NR UE should support PUSCH preparation time described in the table below for slot-based scheduling including CA with
  - no cross-carrier scheduling and
  - with single numerology for PDCCH and PUSCH and
  - for no UCI multiplexing
- PUSCH preparation time is defined as the number of OFDM symbols between the end of UL grant transmission and the start of PUSCH transmission.

Table 6-5 NR baseline PUSCH preparation time

SCS	PUSCH preparation time [symbols]
15kHz	10
30kHz	12
60kHz	23

- NR UE should support asynchronous and adaptive HARQ in DL/ UL.
- NR UE should support code block group based transmission with single/ multi-bit HARQ-ACK feedback and transport block (TB) based transmission.
- NR UE can be configured to monitor group-common PDCCH which carries preemption indication (PI) related to multiplexing with different transmission durations in downlink. Upon reception of PI, a UE should apply appropriate HARQ combining operation.



## 6.2.10 Channel coding

- In NR, LDPC is adopted for eMBB data, and Polar code is adopted for control channel.
  - NR UE should support flexible QC-LDPC as the single channel coding scheme for all block sizes in DL and UL data channels. The supported coding rate ranges from 1/5 to 8/9. The UE channel decoder should have the capability of decoding up to two codewords transmission in DL and one codeword transmission in UL.
  - Both Incremental Redundancy and Chase Combining HARQ for data channel should be supported at UE side.
  - NR UE should support Polar Coding for PBCH and DL/ UL control channel except for very small block lengths where repetition/ simplex/ LTE RM code is preferred. Maximum mother code size of Polar code is  $N_{max,DCI} = 512$  for downlink control information while maximum mother code size of Polar code,  $N_{max,UCI} = 1024$  for uplink control information. Specifically, DCRC-Polar is used for DL and PBCH will reuse DCRC-Polar in DL. While for UL, both CRC-Polar and PC-CA-Polar will be used.
- NR UE should support info block size flexibility and codeword size flexibility where basic code design with rate matching supports 1-bit granularity in codeword size.

## 6.3 Upper Layer Requirements

UE shall support 3GPP Release 15 NR non-standalone mode and NR standalone mode. For the impact of SA and NSA to UE and the device implementation consideration, refer to chapter 8. In this chapter, general upper layer requirements are discussed.

### 6.3.1 Control Plane

- UE shall support three states in RRC: NR\_RRC\_IDLE, NR\_RRC\_INACTIVE, NR\_RRC\_CONNECTED, and the transition between each other except from NR\_RRC\_IDLE to NR\_RRC\_INACTIVE.
- UE shall support 5GC-initiated paging. When UE is inactive state, UE shall support RAN-based notification area update and RAN-initiated paging.
- UE shall support cell specific SIB and area specific SIB. UE shall support on-demand SI. In NR\_RRC\_IDLE and NR\_RRC\_INACTIVE, the request is through a random access procedure via either MSG1 or MSG3.
- UE shall support unified access barring mechanism for all RRC states in NR (NR\_RRC\_IDLE, NR\_RRC\_CONNECTED and NR\_RRC\_INACTIVE).
- UE shall support the following characteristics for cell reselection: Intra-frequency reselection based on ranking, Inter-frequency reselection based on absolute priorities

and inter-RAT cell reselection between NR and E-UTRAN.

- UE shall support to measure multiple beams (at least one) of one NR cell and derive cell quality from these multiple beams (above one threshold). Cell quality from beam measurements is derived in the same way for the serving cell(s) and for the non-serving cell(s). UE shall support to report beam information (beam ID and measurement results) in addition to cell quality results. UE shall support measurement based on SS block and CSI-RS.
- UE shall support beam switch within serving cell and cell level mobility.
- UE shall support inter RAT handover between NR and E-UTRAN.
- Ciphering and integrity protection of RRC and NAS-signaling shall be supported.
- UE shall support cipher algorithm NEA0/ NEA1/ NEA2 and may support NEA3, which algorithms are all defined in TS 33.501.
- UE shall support integrity algorithm NIA0/ NIA1/ NIA2 and may support NIA3, which algorithms are all defined in TS 33.501.
- Carrier Aggregation (CA) is optional to be supported.
- UE shall support radio link failure detection and recovery.
- UE can support Automatic Neighbor Relation (ANR) function.
- UE shall support bandwidth adaptation. For each serving cell, UE can be configured with at most one active bandwidth part at one time.
- Supplemental Uplink is optional to be supported.
- Single Uplink Operation is optional to be supported.
- UE shall support NR E-UTRAN (NE) dual connectivity and UE may support NR dual connectivity.
- UE shall support single registration mode.
- UE shall support network sharing up to 12 PLMNs.
- UE shall support emergency service, voice and video service over IMS in 5G system via NR.
- UE shall support SMS over NAS and SMS over IMS.
- UE shall support IMS Voice Service via EPS Fallback or RAT fallback in 5GS.
- UE shall support Emergency Services via EPS Fallback or RAT fallback in 5GS.
- UE shall support one or more Network Slices simultaneously. UE shall support three Session and Service Continuity modes, i.e. SSC 1, SSC 2 and SSC3.

- UE shall support MM layer and SM layer congestion control.
- UE shall support IPv4, IPv6 and IPv4v6 PDU session types. UE is optional to support IPv6 Multi-homed PDU Session.
- UE is optional to support PS Data Off.
- UE shall support secondary authorization/ authentication by a DN-AAA server.
- Positioning: reserved

### 6.3.2 User Plane

- UE can support ROHC as Header compression and decompression in PDCP.
- UE can support PDCP Data PDU duplication in PDCP layer.
- UE can support different RLC mode, i.e., RLC AM, RLC UM and RLC TM.
- UDC may be a further enhancement for NR UL.
- UE shall support different TTI duration length as different numerology corresponds to different TTI duration length.
- UE shall support scheduling information report such as multiple scheduling request report associated to multiple scheduling request configurations, buffer status report, power headroom report.
- UE shall support DL Semi-Persistent Scheduling (SPS) (i.e. Configured Scheduling). UE shall support UL Type 1 and Type 2 Configured Scheduling (CS).
- UE shall support DRX in NR\_RRC\_CONNECTED for power saving.
- UE shall support contention-based random access procedure and contention-free random access procedure. UE shall support prioritized random access procedure except normal random access procedure.
- UE shall support Logical Channel Prioritization procedure. UE is optional to support logical channel restriction.
- UE may support beam failure recovery procedure.
- UE should support error correction through HARQ.
- UE may support NR MIMO operation through MAC CE, such as SP CSI-RS / CSI-IM Resource Set Activation/Deactivation MAC CE and Aperiodic CSI Trigger State Subselection MAC CE etc.
- UE shall support 5G QoS.
- UE shall support ciphering and integrity protection of CP and UP data between the UE and gNB. UP integrity is mandatory to support and optional to use by 5G UEs and 5G

networks, with the exception of 5G UEs that can only access the EPC.

- UE shall support cipher algorithm NEA0/ NEA1/ NEA2 and may support NEA3, which algorithms are all defined in TS 33.501.
- UE shall support integrity algorithm NIA0/ NIA1/ NIA2 and may support NIA3, which algorithms are all defined in TS 33.501.

## 6.4 Summary

This section provides a high level summary of the key requirements for a sub-6GHz 5G device.

- (1) The device is required support for HPUE (26dBm) on TDD bands.
- (2) To take full advantage of MIMO, the device shall support SRS with Tx antenna switching across multiple Tx antennas.
- (3) In NSA mode, device shall be capable of simultaneous transmission (and reception) across LTE and NR.
- (4) LTE and NR may be deployed in same band and hence in-device co-existence is critical for its operation.
- (5) Initial NSA deployments are expected to use dual connectivity architecture option 3/ 3a/ 3x.
- (6) For LTE in dual connectivity, it is expected support of at least LTE 3CA DL (contiguous and non-contiguous) and LTE 2CA UL (contiguous).
- (7) 1Tx LTE and 1Tx NR would be a default dual connectivity configuration. However, reusing the Tx chains, 2Tx (UL MIMO) can be used in "LTE only" coverage area or in "NR only" coverage area. 2Tx can also be used in TDM mode between LTE and NR. Please note that 2Tx is anyways a key requirement for standalone NR operation.
- (8) The device shall support 15 KHz and 30 KHz subcarrier spacing for NR. 60 KHz is optional.
- (9) Channel coding requires support for LDPC (eMBB data) and Polar coding (Control channel).
- (10) The device shall support UL RoHC as defined in 3GPP.
- (11) In NSA mode, the device is recommended support peak data rate of LTE and NR in dual connectivity same as each in standalone mode.
- (12) The device is recommended support for 2Tx 26dBm + 26dBm on TDD bands.

## 7 Multi-Mode Multi-Band

Telecommunication industry, in general, is moving towards 5G rapidly. At the same time, existing LTE Advanced pro deployments continues to grow and is expected to last for another decade or more. Initial 5G deployments are expected to start from 2018-2019. Depending on operator's network architecture, there would be different mainstream approaches for 5G deployments, such as Standalone (SA) and Non-Standalone (NSA) 5G networks. A 5G UE should support both standalone and non-standalone 5G operations. For the Non-standalone 5G operations, LTE carrier(s) is mandatory to be the anchor carrier for 5G UEs. Besides LTE and 5G, there may be operators around the globe which relies on 3G and other 2G services (though 2G services may be obsolete or reformed to LTE in near future). All these diverse RATs are potentially also using different bands/ channels globally.

To summarize, 5G UE should support some of the following networks:

- 5G/ NR (standalone and non-standalone)
- LTE FDD
- TD-LTE
- WCDMA/ HSPA
- TD-SCDMA/ HSPA
- GSM/EDGE/ GPRS
- CDMA1X/ EVDO

In order to support global roaming as well as local services, 5G UE should support the core bands of 4G/ 3G/ 2G being used worldwide. For 5G bands, it should focus on potential core bands which will be deployed within 3-5 years.

Based on last GTI MMMB requirements, a set of seven core LTE bands were identified which included four key TD-LTE band (Bands 38, 39, 40 and 41) as well as three FDD LTE bands (Bands 3, 7 and 20). Additional bands were identified as core roaming bands (Bands 1, 2, 4, 5, 8, 12, 13, 17, 25, 26, 27, 28, 42 and 43). Support for 2G and 3G may still be required, however, some operators may have re-farmed their legacy 2G networks to LTE. Table 7-1 is below is some GTI operators' recommended bands/ RAT list. It is important to understand other GTI operator's requirements to build a global MMMB device.

Table 7- 1 MMMB device Band list

RAT	Band
NR	Band n77 (3.3 GHz~4.2GHz)
	Band n78 (3.3 GHz~3.8GHz)
	Band n79 (4.4GHz~5GHz)
	Band n1

	Band n3
	Band n8
	Band n41
TD-LTE	Band 40
	Band 38
	Band 39
	Band 41
	Band 34
TD-SCDMA/ TD-HSPA	Band 34
	Band 39
GSM/ GPRS/ EDGE	Band 8
	Band 3
	Band 2
	Band 5
LTE FDD	Band 7
	Band 1
	Band 3
	Band 17
	Band 4
	Band 20
	Band 8
	Band 25
	Band 26
	Band 12
WCDMA/ HSPA	Band 1
	Band 2
	Band 5
	Band 8

The above-listed bands for 5G are only Sub-6GHz. The millimeter wave (mmWave) bands provide plentiful spectrum for 5G, which will rise the requirement of supporting mmWave for 5G UEs. The specified requirements for mmWave will be updated according to the progress of spectrum allocation and operators' deployment.

RF front end architecture to support these various RAT and bands in a discrete manner may provide good RF performance but at the same time pose huge challenges in terms of cost, space and parts availabilities. Multi-mode Multi-band integrated RF architecture could help overcome many of the challenges posed by discrete design. Such architecture would combine several bands into a single chain, independent of RAT.

RF front-end subsystem consists of a combination of power amplifiers (i.e P.A), filters, duplexers, RF switches, resistors, capacitors, and inductors that helps with device conformance to 3GPP and national regulatory emission specifications. Figure below represents a logical partition of bands required in a multi-mode multi-band global

smartphone device. It is understandable that various OEMs may combine RF front-end components in different grouping depending on component selection and functionality provided by those components for CA and connectivity purposes. Various architectures currently also combines mid bands (1.7-2.1 GHz) and the mid-high bands (2.3-2.7 GHz) into a single module to simplify CA. Similarly, high bands could be combined with Wi-Fi or even with mid-high bands and hence share antennas. It should be mentioned that the architecture below may not support multi-RAT simultaneous transmission/ dual connectivity but may be suitable for Standalone architecture.

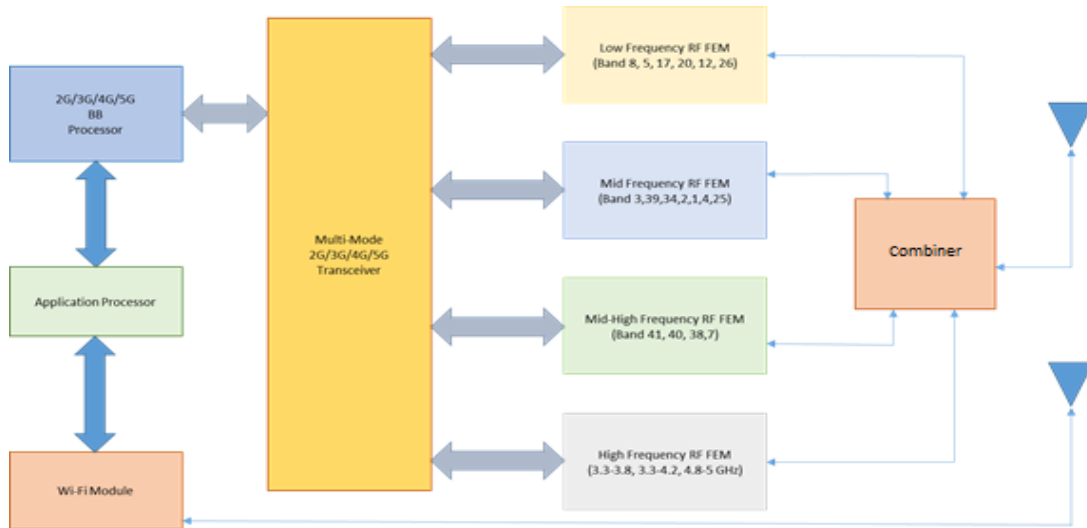

Figure 7-1 MMMB architecture 1

Figure below illustrates a variant of MMMB architecture. The main difference between this architecture (below) and the one described above is the simultaneous handling of multi-mode 2/ 3/ 4/ 5G technologies through single/ multiple baseband chipset. While this architecture provides simultaneous transmission support for 2/ 3G or 5G and LTE, it may require analysis on power consumption and space. Non-standalone/ Dual connectivity architecture may benefit from such architecture. It should be noted that this complexity and extra cost is well understood in the industry and smartphones using such designs have progressed significantly in the last years.

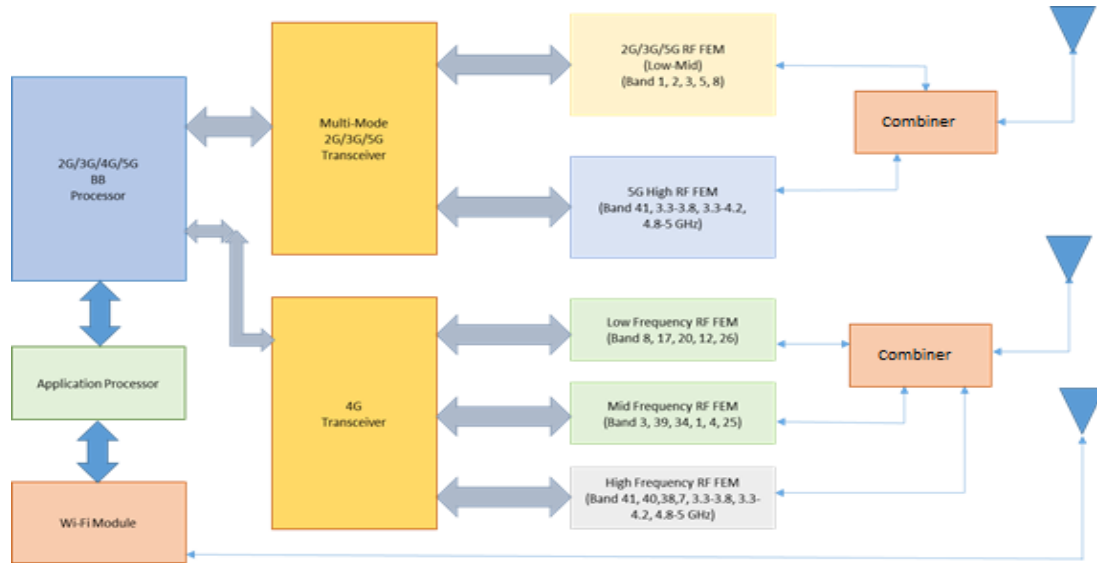

Figure 7-2 MMMB architecture 2

In this example, same baseband processor and multiple transceivers are required to simultaneously support 4G and 5G as well as 2/ 3G technologies. It should be mentioned that other functionality partition on baseband processors is possible. For instance, 5G and LTE could be part of a single processor while 2G/ 3G is addressed by a separate processor. Also, the application processor may well be integrated as part of baseband processor. Also, in some cases, the transceiver and the baseband processor could be integrated in a single chipset.

Besides Band and RAT support, it is also important to account for Channel BW, number of Rx/ Tx antennas, UL Tx power, MCS, CA configurations per RAT, other connectivity and co-existence requirements when designing a multi-mode multi-band device supporting NR and LTE.

## 8 Network Access Capability

This section looks at 5G Network Architecture options supporting standalone and non-standalone mode of operation.

### 8.1 Connectivity Options in 3GPP

3GPP defines both Standalone (SA) and Non-Standalone (NSA) deployment configurations for NR.

#### 8.1.1 Standalone NR

A standalone NR deployment configuration would not require an associated LTE network. The NR-capable UE could use random access to directly establish a radio link with a gNB, and attach to the 5GC to establish service. This would be the simplest configuration



architecture, and would allow the simplest UE implementation.

Standalone NR requires a complete set of specification from 3GPP for all interfaces in the network. 3GPP plans to complete specifications for basic standalone NR in Rel-15, to be approved in June 2018.

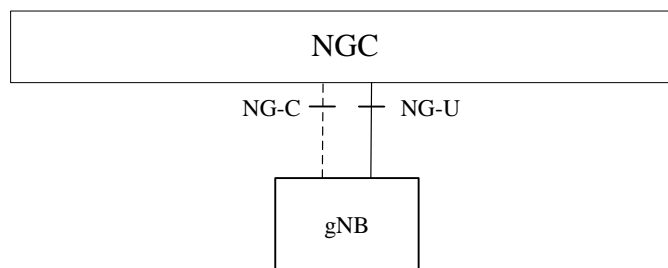

Figure 8-1 Standalone NR – 3GPP Option 2

For Standalone operation, the basic network access principles/ procedures follow LTE counterparts. The additional requirements mainly include:

1. System information (SI) broadcasting: NR system Information is divided into Minimum SI and Other SI.
  - Minimum SI: periodically broadcast and comprises of basic information required for initial access and the scheduling information for other SI.
  - Other SI: encompasses everything not broadcasted in the Minimum SI, which may either be broadcasted, or provisioned in a dedicated manner. Both manners can be either triggered by the network configuration or upon request from the UE (i.e., on-demand)

Compared to LTE SI broadcasting method, on-demand SI broadcasting is a new mechanism introduced in NR to deliver “other SI” by UE request. For UEs in RRC\_CONNECTED, dedicated RRC signaling is used for the request and delivery of the Other SI. For UEs in RRC\_IDLE and RRC\_INACTIVE, making the request will trigger a random access procedure.

2. Access control: Unlike LTE, one unified access barring mechanism will be introduced in NR to address all the use cases and scenarios that E-UTRA addressed with different specialized mechanisms. And, the unified access barring mechanism should be applicable for all RRC states in NR (RRC\_IDLE, RRC\_CONNECTED and RRC\_INACTIVE).
3. RRC\_Inactive: This is a new RRC state in NR, in addition to RRC\_Idle and RRC\_Connected. It is a state where a UE remains in CM-CONNECTED and able to move within an area configured by NG-RAN (i.e., RAN-based notification area, RNA) without notifying NG-RAN. In RRC\_INACTIVE, the last serving NG-RAN node keeps the UE context and the UE-associated NG connection with the serving AMF and UPF. The UE notifies the network via “RAN-based notification area update (RNAU)” procedure if it moves out of the configured RNA.

4. Inter-RAT mobility: for NR, the main inter-RAT scenario is handover-to-LTE. For the more detail, please refer to Chapter 9.

### 8.1.2 Non-Standalone NR

As an interim step for NR deployments, 3GPP has defined non-standalone deployment configurations, using Dual Connectivity (DC) between the UE and both an NR gNB and LTE eNB.

Because initial NR networks may not have complete coverage, DC can be used to combine the coverage advantage of existing LTE networks with the throughput and latency advantages of NR. However, it requires more complex UE implementations to allow simultaneous connections with both LTE and NR networks, potentially increasing the cost of UEs. This will require more complex UE radio capabilities, including the ability to simultaneously receive DL from NR and LTE on separate bands.

NSA networks use architectures where NR gNBs are associated with LTE eNBs and do not require a two separate signalling connection to the 5GC. These architectures are enumerated based on the control plane and user plane connections used between eNB, gNB, EPC, and 5GC, as shown in Table 8-1 below.

Table 8-1 C-Plane/ U-Plane Connections

Dual Connectivity RAN-CN Architecture Options		Core Network	
		4G EPC	5G 5GC
RAN BS with C-Plane and U-Plane connection to Core	LTE eNB	Option 3	Option 7
	NR gNB	N/A	Option 4
"A" suffix means User Plane direct connection with Core exists for both eNB and gNB			
"X" suffix means User Plane direct connection with Core exists for both eNB and gNB with split bearer used for gNB SCG.			

Option 3 architectures use the 4G EPC as the Core Network, with the S1-C control plane connection for the UE between the LTE eNB and the EPC. The gNB acts as Secondary Cell Group (SCG) connected to the Master Cell Group (MCG) at the eNB. Control plane information is exchanged between the eNB and the NR gNB, and no direct control plane interface exists between the gNB and EPC. User Plane bearers are supported between eNB and EPC over S1-U. In option 3A, the gNB also terminates User Plane bearers with the EPC directly. In Option 3X, those gNB terminated S1-U bearers may be split, and carried over the Xx interface to the eNB and over the LTE air interface.

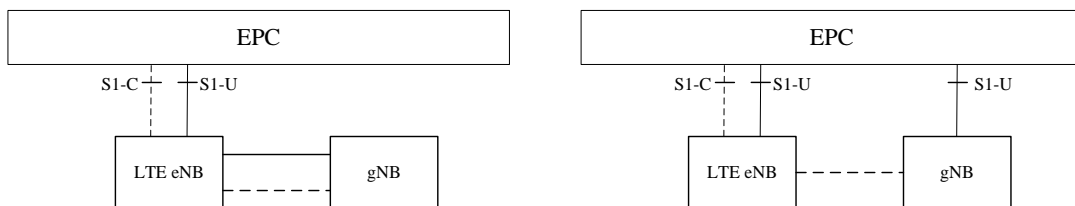

Figure 8-2 Non-Standalone NR – 3GPP Option 3 and 3A

Option 4 is essentially the inverse of Option 3, with the gNB representing the MCG and the eNB representing the SCG. The Control Plane connection is between the gNB and the 5GC over the NG-C, and the eNB gets its control plane information over Xx with gNB. In Option 4A, direct User Plane bearers with the 5GC are terminated at the eNB.

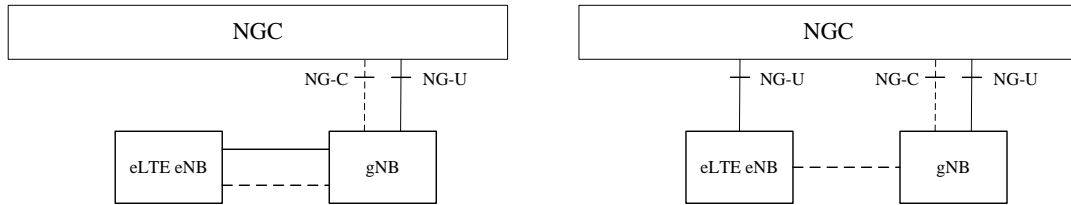

Figure 8-3 Non-Standalone NR – 3GPP Options 4 and 4A

Option 7 uses the same topology as Option 3, with the eNB acting as MCG and the gNB acting as SCG. The difference is that the 5GC Core is used instead of the EPC, requiring the eNB to support eLTE interfaces with the 5GC.

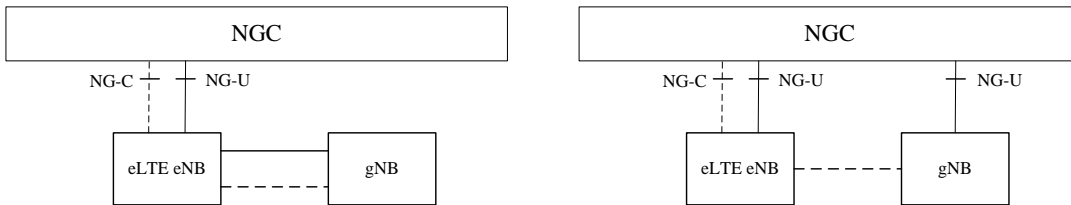

Figure 8-4 Non-Standalone NR – 3GPP Options 7 and 7A

Option 3 does not require interfaces with the 5GC, and allows service over the NR air interface with only the Uu (between UE and gNB) and the Xx (between gNB and LTE eNB) interfaces fully defined. Other network interfaces needed for SA deployment are not needed. As such, it is seen as a likely common architecture for early NR deployments.

From C-plane viewpoint (option 3), there is only one RRC state in UE, which is based on the LTE RRC. And, there is only one C-plane connection towards the Core Network (i.e., EPC for Option-3). Figure 8-4 illustrates the relevant architecture. Each radio node has its own RRC entity which can generate RRC PDUs to be sent to the UE. Note that, RRC PDUs generated by the gNB (SN) can be transported via the LTE Uu interface or NR Uu interface to the UE if configured.

The eNB (MN) always sends the initial SN RRC configuration via MCG SRB (SRB1), but subsequent reconfigurations may be transported via MN or SN. Additionally, the UE can be configured to establish a SRB with the SN (i.e., SRB3) to enable RRC PDUs for the SN to be sent directly between the UE and the SN.

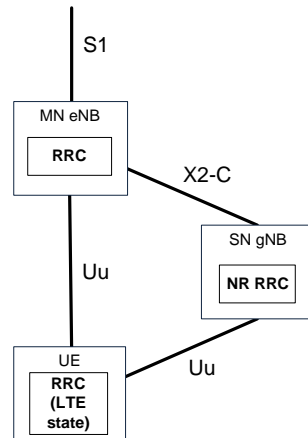

Figure 8-5 Control-plane viewpoint of non-standalone mode

Impacts to RRC procedures for non-standalone operations support include <sup>[5]</sup>:

1. **Secondary Node Addition:** The procedure is initiated by the MN eNB (MeNB) and is used to establish a UE context at the SN gNB (SgNB) to provide radio resources from the SgNB to the UE. This is the first procedure to enable non-standalone operation. After a SN is added, it can be modified or released later.
2. **Secondary Node Modification:** The procedure may be initiated either by the MeNB or by the SgNB and be used to modify, establish or release bearer contexts, to transfer bearer contexts to and from the SgNB or to modify other properties of the UE context within the same SgNB.
3. **Change of Secondary Node:** The procedure is initiated either by MeNB or SgNB and used to transfer a UE context from a source SgNB to a target SgNB and to change the SCG configuration in UE from one SgNB to another. Note that, it always involves signalling over MCG SRB towards the UE.
4. **Inter-Master Node handover without Secondary Node change:** The procedure is used to transfer context data from a source MeNB to a target MeNB while the context at SgNB is kept.

More noticeable requirements in RRC layer to support non-standalone operation are listed below <sup>[6]</sup>:

1. **System information:** For non-standalone operation, UE mainly gets the system information via LTE, except for radio frame timing and SFN from the NR-PSS/ NR-SSS and PBCH of NR cell. After LTE RRC connection is established, system information for initial SN configuration is provided to the UE by dedicated RRC signalling via the MN. Additionally, in non-standalone operation, upon change of the relevant system information of a configured SN, the network releases and subsequently adds the concerned SN cell (with updated U system information).
2. **SRB3 via SN:** SRB3 can be used to send SN RRC Reconfiguration, SN RRC Reconfiguration Complete and SN Measurement Report messages. The objective is

to provide a direct signaling link between NR Uu interface. Similar to one of the SRBs defined in TS 38.331, SRB3 uses NR-DCCH logical channel type, and the RRC PDUs on SRB3 are ciphered and integrity protected using NR PDCP, with security keys derived from S-KgNB. The SgNB selects ciphering and integrity protection algorithms for the SRB3 and indicates them to the MeNB within the SCG Configuration. There is no requirement on the UE to perform any reordering of RRC messages between SRB1 and SRB3.

3. Combined message handling: When both MN and SN reconfigurations are required, the SN RRC reconfiguration message is encapsulated in an MN RRC message that also carries the corresponding MCG reconfiguration that ensures the combined configuration can be jointly processed by the UE. The UE uses a joint success/ failure procedure for messages in an encapsulating MN RRC message. A failure of the MN RRC messages, including one encapsulated SN RRC message with or without any MCG reconfiguration fields, triggers a re-establishment procedure. Each SN RRC reconfiguration message should have its own RRC response message even when the SN RRC message is encapsulated in an MN RRC message. And also, if a SN RRC reconfiguration message is contained in a MN RRC message, the UE sends a MN RRC response message that encapsulates the SN RRC response message.

Measurement: It can be configured independently by the MN (for inter-RAT measurement) and by the SN (intra-RAT measurements on serving and non-serving frequencies). As for the total number of measured carriers across E-UTRA and NR, it is assumed that MN and SN shall coordinate based on UE capabilities. Moreover, if MN and SN both configure measurements on the same carrier frequency, then the configurations need to be consistent. Measurement report can be delivered via SRB1 or SRB3 if configured.

3GPP is prioritizing the specifications for Option 3 NSA networks, scheduled for approval by December 2017 as part of Rel-15.

## 8.2 Uplink Strategies for NR deployment

As part of the Study Item for NR, 3GPP defined multiple scenarios for uplink connectivity between LTE and NR. This subsection will focus on Uplink strategies for NR deployment.

### 8.2.1 Uplink strategies for Standalone Operation

It is known that there is a coverage gap issue between DL and UL. For NR, the gap could be up to 7dB. Two possible uplink strategies can be considered in NR standalone deployments:

- High-band/ low-band carrier aggregation: It follows LTE CA concept by aggregating high-band/ low-band downlink carriers but only transmitting uplink via a low-band carrier. Since low-band carrier has better penetration characteristic, better uplink coverage can be achieved.
- Supplementary uplink (SUL): In SUL, one downlink is paired with two possible uplink

carrier candidates (one is in low-band and the other is in high-band). Similar to CA concept, better uplink coverage can be achieved by selecting low-band carrier for uplink transmission. However, unlike CA concept, there is no direct reference from downlink carrier. Relevant PHY/ protocol enhancements are needed, and the details are FFS. Regarding to SUL detail, please refer to Chapter 11.

## 8.2.2 Uplink strategies for Non-Standalone Operation

Since non-standalone operation is based on EN-DC model, two uplink Tx is the basic assumption. Regarding to the uplink power analysis and possible power reduction solution is discussed in Chapter 13.

For Non-standalone operation, there is inter-modulation (IMD) issue for some specific band combination. For example, if LTE UL is @1.8GHz and NR UL is @3.5GHz, there could be a severe IMD interference to LTE DL @1.8GHz. Currently 3GPP prefer to consider the fall back to single uplink transmission for the problematic band combination, the details will be further specified later. Some further optimization may be considered, but may not be included within 3GPP Rel-15 NR specification:

1. Uplink transmission is alternating between two uplink carriers by semi-static TDM pattern.
2. LTE uplink and NR uplink both transmit onto the same LTE UL carrier, and uplink resource is shared in in TDM manner. In order to achieve this, sub-carrier alignment (shift 7.5kHz) to align the sub-carrier locations for LTE and NR will be necessary. Further details are still under 3GPP standardization process.

## 8.3 UE Modem Challenges and Solutions for Supporting Standalone and Non-Standalone NR

In this section, we discuss the 5G NR UE modem challenges and solutions supporting SA and NSA NR. 3GPP 5G NR Release 15 work plan has the phased release schedule where NSA Option 3 is to be completed first followed by SA Option 2. As some of RAN specification details are still under progress at this point, from UE modem perspective, it is desirable for the 5G modem chip to have an architecture that can support NSA and SA in a unified fashion such that various 5G devices under NSA and SA scenarios can be supported with the same/similar platform. In Section 8.3.1, we discuss the modem architecture for LTE+NR dual connectivity and show the benefits of single-chip modem architecture for NSA. In Section 8.3.2, we discuss the additional challenges and solutions for SA support.

### 8.3.1 UE modem architecture for NR + LTE dual connectivity

In NSA Option 3 EUTRA + NR Dual Connectivity (EN-DC), an LTE component carrier serves a mobility anchor as a master node while NR component carrier provides enhanced data

service as a secondary node.

Two possible approaches for UE baseband modem solutions for NSA are single chip (LTE+NR multi-mode modem) and two-chip (LTE modem + NR modem) architectures<sup>1</sup>. In addition to the obvious area reduction by sharing common blocks such as digital front-end processing within modem SoC, the single-chip solution has inherent advantage for NSA NR operation.

First, unlike LTE and other legacy RAT (e.g. 2G/3G), LTE and NR have inherent commonality in the air-interface due to their nature of OFDM-based signal processing. Single chip architecture can fully share the common HW resources such as FFT engine and reference signal processing. Furthermore, sub-6GHz RF chains (front-end module and RFIC) can be shared between LTE and NR in a similar way of extending carrier aggregation and LTE dual-connectivity capability in LTE Pro Advanced modem. Figure 8-6 shows a potential single-chip modem architecture for NSA.

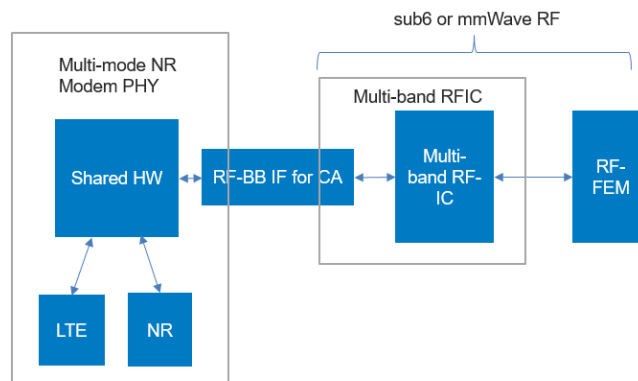

Figure 8-6 Single-chip UE modem architecture for NSA

Figure 8.7 shows another example of efficient uplink transmission with a single chip modem. In NSA at least 2-Tx is required for each LTE and NR uplink transmission. With a single-chip architecture, it is straightforward to support a dynamic power sharing feature in 3GPP standard for LTE+NR dual-connectivity where the total UE transmit power is split dynamically between LTE and NR carriers rather than imposing each carrier with individual (and possibly smaller) transmit power. Such dynamic power sharing can provide enhanced coverage in the scenario of unbalanced link condition between LTE and NR carriers. For SA, the 2-Tx HW capability can be used for NR UL-MIMO transmission as well.

<sup>1</sup> In this section, the term “two-chip architecture” is used in a broad/logical context that refers to the chipset consisting of two independent LTE and NR modem IPs. The final package can be a single (e.g. SiP) or two separate packages. The single-chip architecture refers to a single modem IP that perform both LTE and NR baseband radio processing.

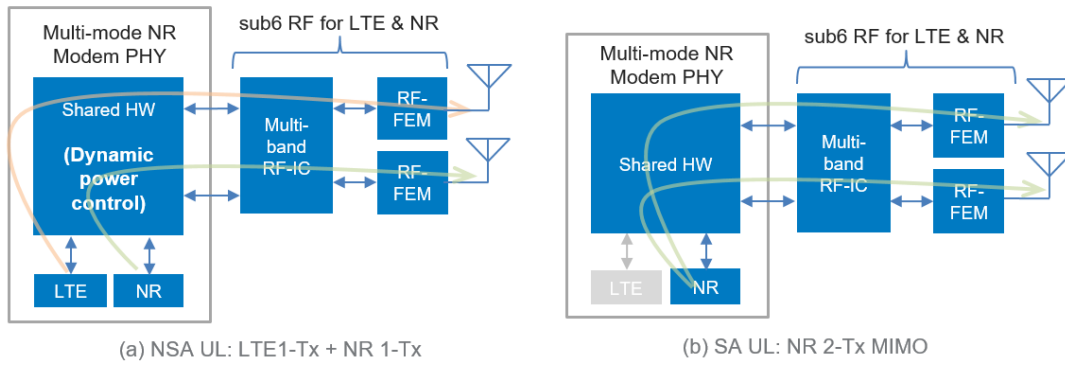

Figure 8-7 LTE+NR Uplink power sharing in NSA and 2-Tx UL-MIMO in SA

In addition to the efficient HW resource sharing and dynamic transmit power sharing, there is also a platform-level simplification in a single chip NSA modem architecture. As shown in Section 8.1.2 and also illustrated in Figure 8-8, in Option 3 and Option 3x, MCG or SCG radio bearer split support is required. Table 8-1 summarizes the comparison of two-chip vs single-chip architecture for radio bearer split support.

From UE perspective, LTE and NR packets should be aggregated at NR PDCP layer in DL traffic and the traffic split need to be performed in UL traffic. The two-chip architecture requires an external high-speed data transfer interface such as PCIe from NR to LTE (Option3) and vice-versa (Option 3x). In the single chip architecture, LTE and NR stack share the common internal memory thereby avoiding the external data loading operation and the need for the external interface. This will provide both power consumption and chip area benefits.

Likewise in UL traffic, PDCP split between LTE and NR Tx should be done. In addition to the external interface for LTE and NR UL data transfer from the host (e.g. application processor), a smart UL split policy entity should reside in both LTE or NR modem side to support MCG and SCG split bearers respectively and this policy entity should have all necessary information of each RAT traffic/radio conditions in order to have intelligent decisions. With a single chip architecture, not only data transfer interface is unified (e.g. the interface from the application processor to the modem can be RAT-agnostic), a unified protocol stack has access to all the required information to make UL split bearer decision. This could be advantageous in sudden change in radio condition that may result in imbalanced uplink coverage between LTE and NR.

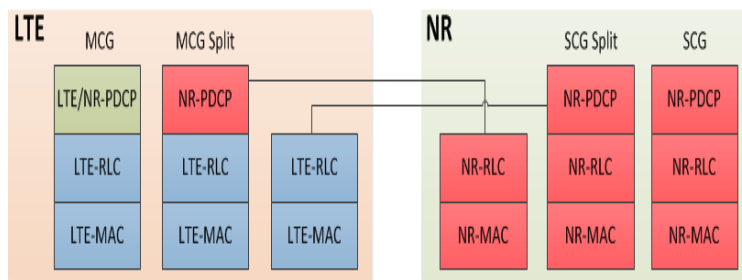

Figure 8-8 NR PDCP aggregation/split for MCG and SCG radio bearer split support in NSA Option3/3x



Table 8-1 Single-chip vs Two-chip architecture for NSA radio bearer split support

	Two-chip	Single-chip
DL PDCP aggregation	Requires external high-speed data transfer interface (e.g. PCIe) from NR to LTE (Option 3) and vice-versa (Option 3x)	LTE and NR stack can share the common internal memory. No extra data loading operation and external transfer interface required.
UL PDCP split policy entity	Both LTE and NR chips have to be involved to support Option 3/3x	Smart decision in a single entity

### 8.3.2 UE modem challenges and solutions for SA

In NSA deployment, most of NR UE modem operation would be focused on the RRC\_CONNECTED scenario. For SA operation, the NR UE modem would need to support full NR-based mobility management and the major features that are only possible with the 5GC core-network in SA NR compared to EPC-based NSA NR. Some of major challenges expected in the pre-commercial and field verification phases for SA NR operations are as follows.

- Physical layer: Optimization of UE power-vs-performance trade-off vs NW efficiency are expected to be carried out in the large-scale pre-commercial trials.
  - System information (SI) processing for idle/in-active state: In NSA, all system information is obtained through LTE master node except the MIB and timing information obtained via SSB (Synchronization Signal Block) of NR carrier. With SA, UE is expected to obtain all the relevant SI in NR carrier to maintain the connectivity. With the efficient resource utilization mechanism in NR, multiple CORESET and BWP operations are expected for RMSI (Remaining SI)/OSI (On-demand SI), newly introduced SI classes in NR SA scenario. Finalization of the spec. details are in the progress. This includes an efficient way of OFDM waveform generation that are agnostic to the actual RF carrier frequency for dynamic BWP operation.
  - Mobility management for connected/idle/in-active state: In connected mode, while the most of mobility management procedures remain the same as NSA, the KPI requirement (e.g. signaling, IMS registration) would be more stringent for seamless user experience and higher user expectation on the initial 5G service. In idle mode, cell-selection and DRX processing are required in NR carrier as well. This may include fast beam management. With removal of always-on RS (e.g. cell-specific RS in LTE), UE control-loop and measurement processing would need to be optimized across different NW deployment scenarios.

- Upper-layer protocol: Major additional requirements in UE modem for SA NR deployments are as follows.
  - RRC\_INACTIVE: Support of new RRC\_INACTIVE state is required for SA operation, which is expected to improve battery life under infrequent background application's keep-alive packet without incurring RRC signaling and long C-DRX penalty. RANU (RAN-area notification update) procedure support is required.
  - New SDAP (Service Data Adaptation Protocol): Support of new sub-layer in NR L2 to enable 5GC features such as reflective QoS and flow-based QoS managements are required.
  - Network slicing: UE assistance information via RRC signaling for RAN-level slice awareness is expected. Beyond the UE-assistance information signaling, further specification/application scenario identification under multiple network slices would be required to obtain meaningful improvements in end-user/network benefits.

In summary, major physical layer challenge in SA deployment is the optimization for power and performance in early NW deployment while benefiting from 5GC features and services. Even though most upper layer protocol changes for SA from NSA are incremental from UE modem perspective, it is important to minimize the burden of UE modem operation and optimization effort in the initial phase of NR SA deployment by identifying the high-priority use-case scenarios for field trials of key SA features like network slicing, reflective QoS, session management for successful adoption of 5G service.

In addition to these changes, there are system-level optimization challenges for interworking with other RATs and paging/IMS services through 5GC. These aspects are discussed in the following sections.

---

## 9 Inter-RAT Interworking

### 9.1 NR mobility state transition

This section will look at LTE and NR interworking scenario as supported by 3GPP. LTE-NR interworking is important for standalone mode of operation between LTE and NR unlike for dual connectivity where there is simultaneous transmission across both RAT's most of the time. Inter-working between LTE and NR is not expected to be significantly different from what is defined in LTE specifications for interworking with other 3G networks. The Inter-RAT mobility is expected to be supported both, in Idle mode as well as connected mode. Figure below illustrates possible mobility scenarios across LTE and NR.

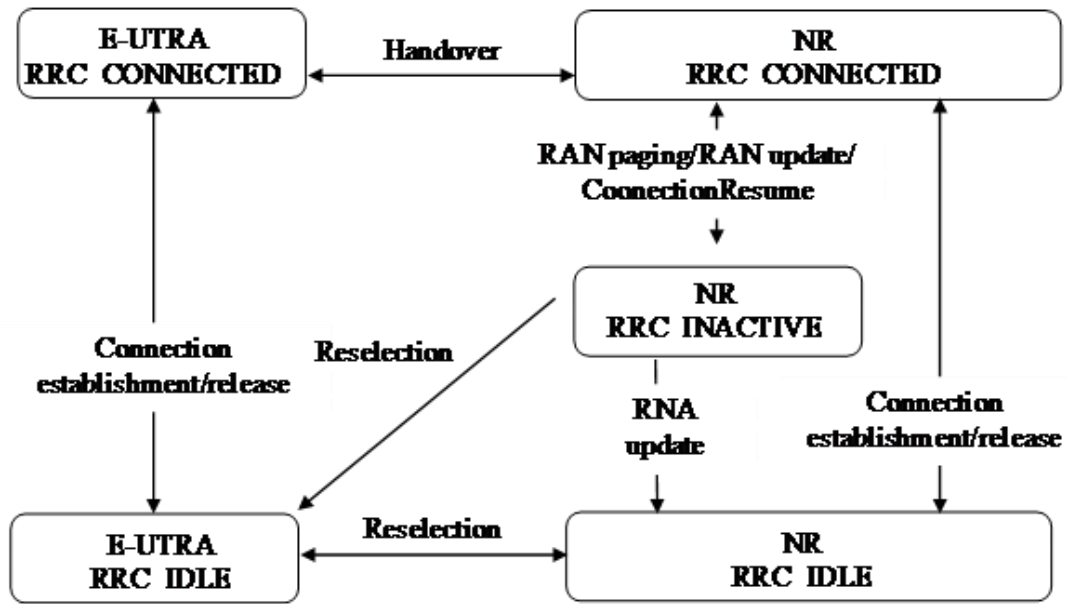

Figure 9-1 LTE-NR mobility state diagram

Connected mode mobility is expected to occur over 'Xn' interface between LTE eNB and NR gNB where both (eNB & gNB) are connected to 5GC core network. S1/ N2 (CN based) based Handover is supported where LTE eNB is connected to EPC and NR gNB is connected to 5GC. Xn and CN HO over NG Core (eNB & gNB connected to 5GC) is supported by RAN2, which is transparent from UE perspective. Lossless HO is expected based on tight interworking between RATs when connected to 5GC core. Source RAT shall support configuring target RAT measurement and reporting for inter-RAT HO. High level call flow for both scenarios are illustrated in the figure below.

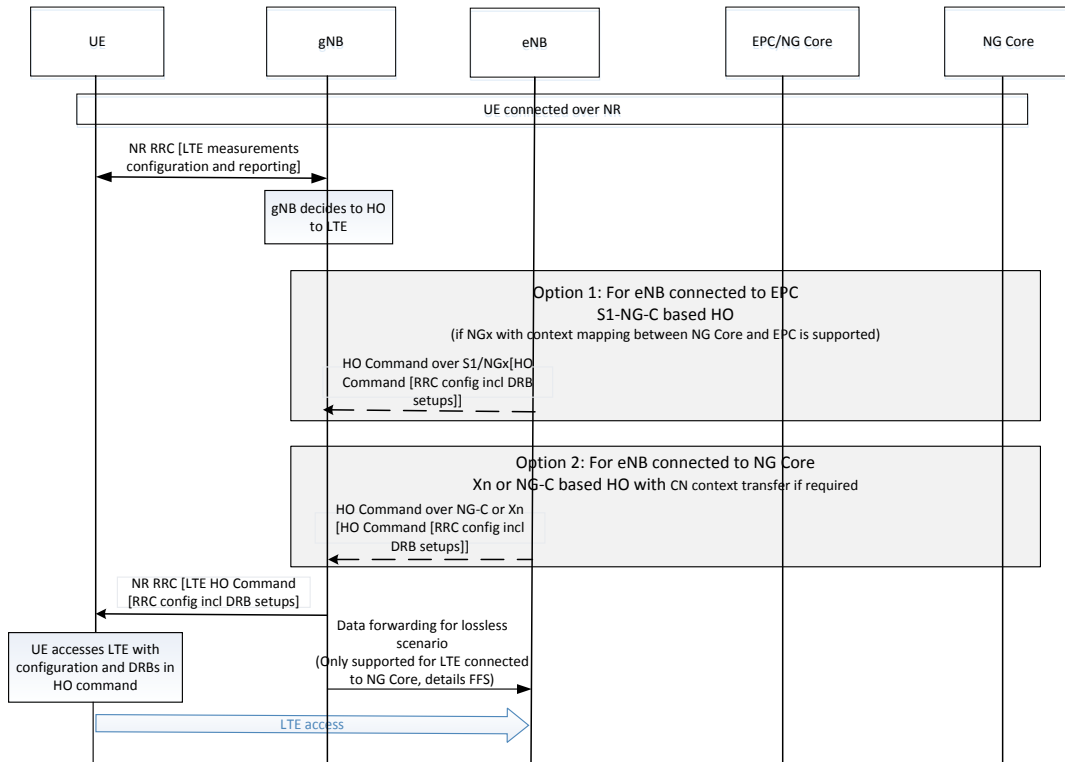

Figure 9-2 NR to LTE Connected state mobility

Interworking between NR and LTE is expected to also support both collocated and non-collocated site deployments.

For Standalone Option-2 handover between NR and LTE mode, in addition to RAN-level handover, CN change is also included. The procedures for inter-system change are described in sub-section below.

## 9.2 Inter-System Procedure

If the UE supports both 5GC and EPC NAS, it can support inter-system interworking and operates in either single-registration mode or dual-registration mode.

- In single-registration mode, UE is either in 5GC NAS mode or in EPC NAS mode. Therefore, UE is required to handle only one active MM state (either RM state in 5GC or EMM state in EPC).
- In dual-registration mode, the UE may be registered to 5GC only, EPC only, or to both 5GC and EPC. Therefore, UE is required to handle independent registrations for 5GC and EPC.

Because 3GPP SA2 already have clear preference to use single-registration mode, the following introduction will only base on single registration mode. N26 interface is an inter-CN interface between the MME and 5GS AMF in order to enable interworking between EPC and the 5GC. Support of N26 interface in the network is optional for interworking.

## 9.2.1 Interworking Procedures with N26 interface

Interworking procedures using the N26 interface enables the exchange of MM and SM states between the source and target network (i.e., between 5GC and EPC). When interworking procedures with N26 is used, the UE operates in single-registration mode.

### Mobility for UEs in single-registration mode:

When the UE supports single-registration mode and network supports interworking procedure with the N26 interface:

- For idle-mode mobility from 5GC to EPC, the UE performs either TAU or Attach procedure with EPS GUTI mapped from 5G-GUTI sent as old Native GUTI.
- For connected-mode mobility from 5GC to EPC, either inter-system handover or RRC connection release with redirection to E-UTRAN is performed. During the TAU or Attach procedure the HSS+UDM cancels any AMF registration associated with the 3GPP access.
- For idle-mode mobility from EPC to 5GC, the UE performs mobility registration procedure with the 5G GUTI mapped from EPS GUTI and indicates it is moving from EPC. The UE also includes the native 5G-GUTI as an additional GUTI in the Registration request.
- For connected-mode mobility from EPC to 5GC, either inter-system handover or RRC connection release with redirection to NG-RAN is performed. During the Registration procedure, the HSS+UDM cancels any MME registration.

## 9.2.2 Interworking Procedures without N26 interface

For interworking without the N26 interface, IP address continuity is provided to the UEs on inter-system mobility by storing and fetching PGW-C+SMF and corresponding APN/ DDN information via the HSS+UDM. In such networks AMF also provides an indication that interworking without N26 is supported to UEs during initial Registration in 5GC or MME may optionally provide an indication that interworking without N26 is supported in the Attach procedure in EPC. This indication is valid for the entire Registered PLMN and for PLMNs equivalent to the Registered PLMN.

### Mobility for UEs in single-registration mode:

When the UE supports single-registration mode and network supports interworking procedure without N26 interface:

- For mobility from 5GC to EPC, the UE with at least one PDU Session established in 5GC
  - o if supported and if it has received the network indication that interworking without N26 is supported, perform Attach in EPC with EPS GUTI mapped from 5G-GUTI sent as old Native GUTI and with Request type "Handover" in PDN

CONNECTIVITY Request message and subsequently moves all its other PDU session from 5GC to EPC, or.

- Perform TAU with 4G-GUTI mapped from 5G-GUTI, in which case the MME instructs the UE to re-attach. IP address preservation is not provided in this case.
- For mobility from 5GC to EPC, the UE with no PDU Session established in 5GC
  - performs Attach in EPC indicating that the UE is moving from 5GC.
- For mobility from EPC to 5GC, the UE performs Registration of type "mobility registration update" in 5GC with 5G-GUTI mapped from EPS GUTI. The AMF determines that old node is an MME, but proceeds as if the Registration is of type "initial registration". The UE may subsequently either:
  - if supported and if it has received the network indication that dual registration mode is supported, move all its PDN connections from EPC to 5GC, or
  - Re-establish PDU sessions corresponding to the PDN connections that it had in EPS. IP address preservation is not provided in this case.

---

## 10 Voice Solution

The voice service is not only a traditional and typical service but also a reliable and high quality telecommunication service, and it will continue to serve in 5G era.

The proposed basic principle and goal for voice service:

- IMS based
- Mobility and seamless continuity between 5G and 4G
- The interrupt duration up to 300ms

During the standard discussion, operators show different preferences on the network architecture options. For example, some operators show interests on Option 3 (Non-Standalone) which requires gNB connect EPC/ LTE; and some operators show preference on Option 2 (Standalone) which 5GC connects gNB. More preference also be identified during the discussion since operators have different deployment strategies. We can foresee the 5G network might be much more complicated than the network we have now. This section looks at the potential voice solutions for the different network scenarios.

### 10.1 Potential solutions

Based on 3GPP Rel-15, we summarize the potential solutions as follows:

- VoNR

- EPS Fallback
- Dual Standby

For other network options, the voice solution might be different due to operators might have different deployment preference.

### 1. VoNR

Generally, the procedure of VoNR is similar with VoLTE with little updates.

UE reports the IMS voice capability and UE usage setting information to the AMF during the registration procedure, and then AMF requests the UE radio/ RAN capability and Compatibility for IMS voice of PS session. The serving PLMN AMF is expected to send an indication toward the UE during the Registration procedure to indicate the availability of IMS voice over PS session.

To allow for appropriate domain selection for originating voice calls, the UE shall attempt initial registration in 5GC. If the UE fails to use IMS for voice, e.g. due to "IMS voice over PS session supported indication" indicates voice is not supported in 5G System, the UE behaves as described below for "voice centric" for 5GS or "data centric" for 5GS:

- A UE set to "voice centric" for 5GS shall always try to ensure that Voice service is possible. A voice centric 5GC capable and EPC capable UE unable to obtain voice service in 5GS shall not select a cell connected only to 5GC. By disabling capabilities to access 5GS, the UE re-selects to E-UTRAN connected to EPC first (if available). When the UE selects E-UTRAN connected to EPC, the UE performs Voice Domain Selection procedures as defined in TS 23.221.
- A UE set to "data centric" for 5GS does not need to perform any reselection if voice services cannot be obtained.

### 2. EPS Fallback

The Handover could be triggered by voice bearer establishment, gNB can initiate an inter-RAT HO procedure to EPC, or fall back the call to LTE. The voice will be delivered over EPC if EPC supports VoLTE (In case EPC does not support VoLTE, the voice may be delivered over 2/ 3G via EPC).

### 3. Dual-Standby

From the experience from the early stage of LTE deployment, some dual-standby solutions like PS + CS solution (SG-LTE/ SV-LTE) are reasonable before VoIP (VoLTE or VoNR) becomes mature. These solutions only require limited standard efforts and network investment but can provide stable voice in early stage of each generation.

As operators may need some time to deploy a 5G network to provide stable VoNR service, the dual-standby solution (e.g. PS+CS or VoLTE+NR concurrence) could be a promising way when operators start to deploy 5G network.

Generally, the dual-standby solution provides a single link for voice by CS or CSFB or VoLTE/SRVCC, and the rest link is for NR PS data. The dual-standby solution can be a single RF chain or multiple RF chain, and the UE can disable the data connection when voice link is activated and resume back when voice finishes.

Dual registration is one of the dual-standby solution which requires further standardization efforts before commercialization.

## 10.2 Summary

### For SA:

- Scenario 1: SA with N26 between AMF in 5GC and MME in EPC

With the N26 interface between AMF and MME, the session can be seamlessly transferred from source network to target network when inter-system change occurs. The UE maintains a single registration for 5GC and EPC.

The voice service can be provided over 5G NR (VoNR) with single registration mode. If 5GS is not ready for VoNR, gNB can trigger the fall back to EPS and voice service can be provided with VoLTE.

- Scenario 2: SA without N26 between AMF in 5GC and MME in EPC

Without the N26 interface between AMF and MME, the session could not be seamlessly transferred from source network to target network when inter-system change occurs.

In 3GPP, how to support voice is under discussion for the dual registration UE. When UE registers on 4G and 5G concurrently, the session context may be transferred and resumed by UE from source network to target network, but the session interruption duration depends on UE itself design.

### For NSA:

In NSA, for example option 3, the dual connectivity would be supported, primary one for CP (signal) over LTE and secondary one for UP (media) over NR. As to Voice service, the dual connectivity may be not required, and voice service would be provided on LTE connectivity with VoLTE.



## 11 RF Performance

### 11.1 High Power UE

#### 11.1.1 Motivation

Due to different TX/ RX configurations and network deployment between downlink (DL) and uplink (UL), for example, transmitted power and antenna numbers, 4G LTE coverage in general limited in UL. According to the evaluation done for LTE Band 41 Power Class 2 (+26dBm) <sup>[8]</sup>, the coverage asymmetry could be up to 5 dB based on the network deployment parameters. To improve UL coverage, an effective way is to increase its transmitted power.

Based on some initial analysis of 5G NR link budget, it would suffer the same system bottleneck. Therefore operators proposed to specify both Power Class 2 (+26 dBm) and Power Class 3 (+23 dBm) UE in 3GPP RAN4 <sup>[9]</sup>.

#### 11.1.2 3GPP Status

Power Class 2 has been introduced to LTE Band 41 to enhance UL coverage. Currently, the NR work item of high power UE for 3.5 GHz frequency range has been approved in RAN4 and other bands such as n41 are expected to be added in the specifications as well. Several other topics will be evaluated in the following RAN meetings, including the co-existence of NR-to-NR and NR-to-LTE, UE TX/ RX characteristics, and specific absorption rate (SAR) related issue, etc. The work plan is expected to be completed by March 2018 <sup>[10]</sup>.

#### 11.1.3 TX Front-end Status and Architecture for HPUE

Power amplifier (PA) would be the most critical FE component to support NR HPUE. In Table 11-1, preliminary power gain and maximum output power of 3.5 GHz PA from two vendors are summarized. Depending on different front-end architecture/ component, the post-PA insertion loss will be different. However, around 4 to 6 dB loss should be a reasonable number at this frequency range. In that case, it is actually marginal or even not feasible to achieve 26 dBm antenna power with any one of these two PAs. We expect the PA Pmax should be further improved for NR HPUE application.

Table 11-1 Preliminary Power Amplifier Data in NR 3.5 GHz Band

Vendor	PA Gain (dB)	Pmax (dBm)
A	30	30.8
B	26	30

According to the agreement in 3GPP RAN4, NR non-standalone mode, i.e., NR and LTE dual connectivity, would be the first priority in Release 15. Figure 11-1 shows an example of front-end architecture that can support NR 2x2 MIMO and LTE dual connectivity. One of the

advantage to have NR 2x2 MIMO is that 26 dBm transmitted power can be achieved with two Power Class 3 PAs, which significantly relieves PA Pmax requirement.

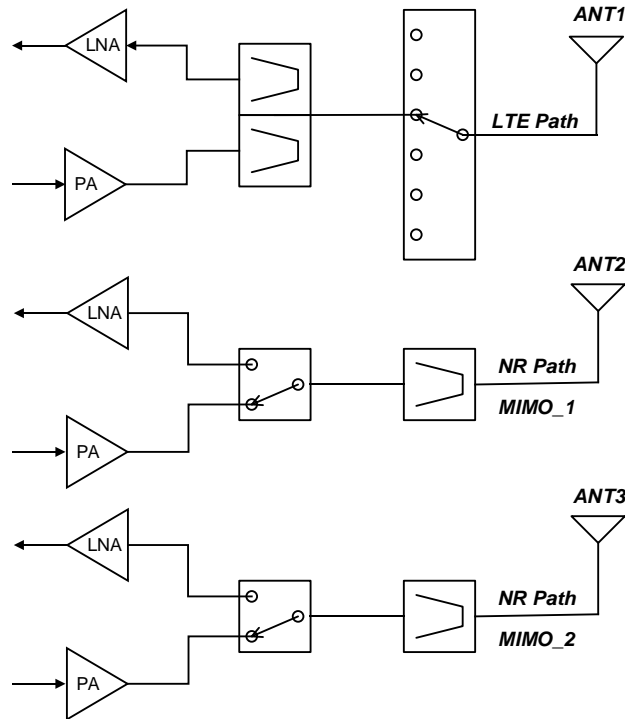

Figure 11-1 Example of front-end architecture supporting NR 2x2 MIMO and LTE dual connectivity

#### 11.1.4 Consideration on Thermal for HPUE

It is intuitive that one side effect of HPUE is the total power consumption increase, especially from the power amplifier. Moreover, it is also expected that the power consumption of MODEM will increase significantly due to the wider transmission bandwidth in 5G NR. Thermal becomes a challenging issue from UE manufacturer point of view.

In this section, a preliminary thermal budget and the corresponding phone surface temperature was analysed based on a 5.5 inch phone model. The evaluation considers UE operating in NR NSA mode. The output power of LTE FDD TX is 23 dBm, while the output power of NR TDD TX is 23/ 26 dBm, as shown in Figure 11-2. Assuming a 45°C phone surface temperature design target in real network application, it can be seen in Table 11-2 that only the lowest NR UL duty cycle, 11.67%, can meet the requirement if UE TX transmits LTE 23 dBm and NR 26 dBm (23+23) simultaneously. On the other hand, when UE TX power is backed off to LTE 23 dBm and NR 23 dBm (20+20), then NR UL duty cycle can be increased to 31.67% as shown in Table 11-3. According to the analysis, it seems that total TX transmitted power of 26 dBm is more feasible for implementation. Another viewpoint is that the chance to continuously transmit maximum output power for a long period for an UE should be low in real network. Therefore, the data in Table 11-2 and Table 11-3 could be considered as worst case and define a relaxed target of 52°C phone surface temperature. Then the

applicable NR UL duty cycle can be further improved.

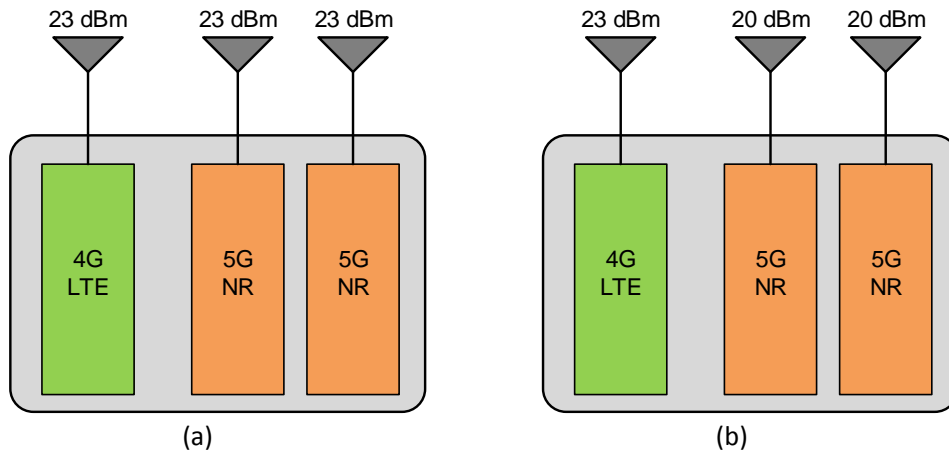

Table 11-2 LTE FDD (23 dBm) + NR TDD 2x2 MIMO (23 + 23 dBm)

LTE FDD 23 dBm NR TDD 23+23 dBm	NR UL Duty Cycle (Re-use LTE TDD Configuration)						
	63.33 %	53.33 %	43.33 %	31.67 %	23.33 %	21.67 %	11.67 %
Phone Surface Temperature (°C)	61.5	57.7	53.9	49.5	46.3	45.7	41.9

Table 11-3 LTE FDD (23 dBm) + NR TDD 2x2 MIMO (20 + 20 dBm)

LTE FDD 23 dBm NR TDD 20+20 dBm	NR UL Duty Cycle (Re-use LTE TDD Configuration)						
	63.33 %	53.33 %	43.33 %	31.67 %	23.33 %	21.67 %	11.67 %
Phone Surface Temperature (°C)	52.7	50.2	47.8	45.0	43.0	42.6	40.2

### 11.1.5 Consideration on SAR for HPUE

Due to the higher transmitted power than nominal Power Class 3 UE, SAR evaluation for NR HPUE is quite critical. In a similar fashion, UE with transmitted power of LTE FDD 23 dBm and NR TDD 26 dBm (63.33% UL duty cycle) is treated as a baseline. Please be noted that WiFi TX is also considered in this analysis. The results in Table 11-4 compare the SAR value varying with different NR UL duty cycle. The duty cycle has to be lower than 31.67% in order to pass the SAR limit, 2 mW/ 10g. In summary, a total TX transmitted power of 26 dBm is more practical in terms of SAR. Otherwise, the UL duty cycle would be quite limited.

Table 11-4 Body SAR Analysis – LTE FDD (23 dBm) + NR TDD 2x2 MIMO (23 + 23 dBm) + WiFi

	Total SAR (mW/10g)	SAR limit (mW/10g)	NR UL Duty Cycle
Body SAR	2.841	2	63.33 %
Body SAR	2.592	2	53.33 %
Body SAR	2.342	2	43.33 %
Body SAR	2.051	2	31.67 %
Body SAR	1.843	2	23.33 %
Body SAR	1.802	2	21.67 %
Body SAR	1.552	2	11.67 %

Table 11-5 Body SAR Analysis – LTE TDD (23 dBm) + NR TDD 2x2 MIMO (23 + 23 dBm) + WiFi

	Total SAR (mW/10g)	SAR limit (mW/10g)	NR UL Duty Cycle
Body SAR	2.470	2	63.33 %
Body SAR	2.221	2	53.33 %
Body SAR	1.971	2	43.33 %
Body SAR	1.680	2	31.67 %
Body SAR	1.472	2	23.33 %
Body SAR	1.431	2	21.67 %
Body SAR	1.181	2	11.67 %

## 11.2 In-Device Interference

There are two basic deployment policies for 5G network depending on the preferences of each operator: standalone deployment and non-standalone deployment.

For standalone deployment, the NR system can work independently with LTE. Thus a single connectivity with NR network is the basic operation for the UE. In this case, single UL transmission mode is sufficient as baseline.

To further enhance the standalone deployment, there may be various ways for different targets, e.g.:

- Throughput enhancement: Carrier aggregation of NR-NR can be used to boost user data rate.
- Coverage enhancement: SUL (Supplementary Uplink) is using a lower-frequency carrier for NR UL transmission in addition to NR's dedicated UL carrier. Due to the lower frequency, the UL coverage can be significantly improved by transmission on SUL.

For the above enhancements, UE may support simultaneous transmission of more than one UL in different bands, which may potentially lead to in-device interference.

For non-standalone deployment, UE should support the dual-connectivity of LTE and NR, where LTE carrier is always the anchor carrier. In this case, UE may also encounter the in-device interference issue.

In summary, except the standalone NR operation with one UL band, UE may suffer from in-device interference due to simultaneous UL transmissions in the non-standalone deployment and some enhancements of standalone deployment.

There are three different types of in-device interference due to simultaneous UL(s)/ DL(s) transmission over different bands:

- Interference from Harmonic

This kind of interference comes from the harmonic of lower- frequency UL signals to the higher- frequency DL signals when the harmonic of UL frequency falls into the DL frequency. Figure 11-3 shows the case with LTE on a lower- frequency carrier and NR on a higher- frequency carrier. One example is that when a UE is simultaneously transmitting on B3 (LTE) and receiving on NR sub-6G band B42 (3.4G~3.6G), interference from H2 of B3 will fall into NR receiver.

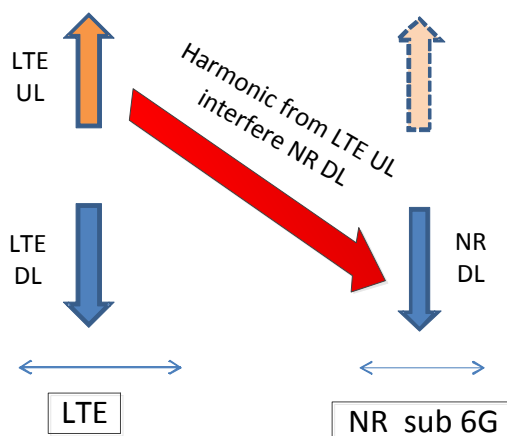

Figure 11-3 Illustration of interference from Harmonic

- Interference from Harmonic mixing

This kind of interference comes from higher frequency UL signals to the lower-frequency DL signals when the higher frequency is multiple of the lower frequency. Figure 11-4 shows the case with LTE on a lower- frequency carrier and NR on a higher-frequency carrier. One example is that when a UE is simultaneously transmitting on 3.3G~4.2G and receiving on LTE B26, interference from UL will fall into LTE B26 receiver and be demoded by receiver which causes sensitivity degradation.

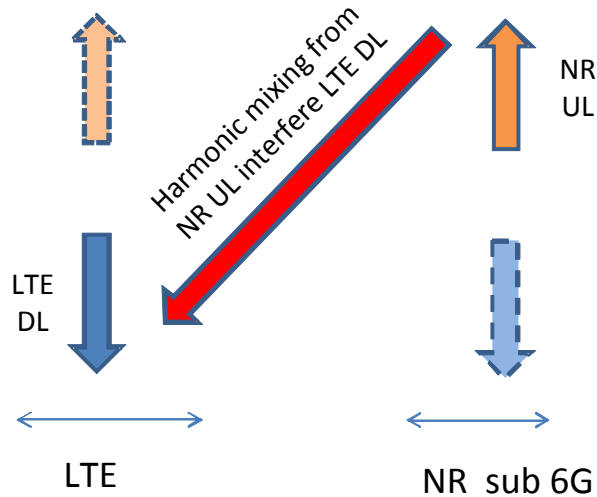

Figure 11-4 Illustration of interference from Harmonic mixing

To address the interference from Harmonic or Harmonic mixing, the main solution is based on the transmission coordination between UL and DL transmission. Two different approaches have been identified as the solutions:

- TDM
- FDM

It means NW can schedule the DL and UL to avoid the interference. However, these solutions will require the LTE NW and NR NW to share/ exchange information, which may lead to some potential challenges in the multi-vendor deployment scenarios.

- Interference from Intermodulation (IMD)

This kind of interference comes from the intermodulation (IMD) product between lower-frequency and higher-frequency UL carriers which may fall into the DL carrier. Figure 11-5 shows the case with LTE on a lower- frequency carrier and NR on a higher-frequency carrier. One example is that when a UE is transmitting simultaneously on B3 (LTE) and NR sub-6G band (3.3G~4.2G), interference of IM2/ IM4/ IM5 will fall into B1 LTE receiver.

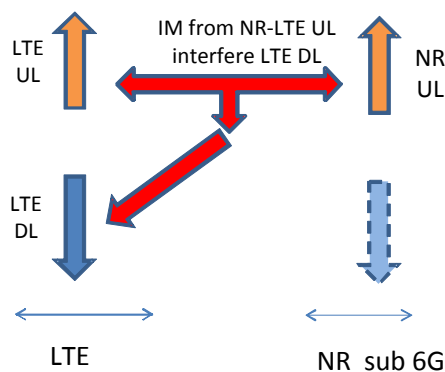

Figure 11-5 Illustration of interference from IMD

To address the IMD issues, there are some potential ways

- Spectrum allocation
- Single UL transmission

However, spectrum allocation is not always useful due to too many limitations. Thus single UL transmission has been agreed as a solution in 3GPP. Since the IMD interference is highly related to the band combinations, UE may support simultaneous UL transmissions for some band combinations while can only support single UL transmission for other band combinations. To facilitate NW's scheduling, UE can report its capability whether or not support simultaneous UL transmissions based on the band-combination basis, and NW decide the configuration/ scheduling based on UE's capability report.

To mitigate the effects of IMD, 3GPP NR designs single Tx operation. During the single Tx operation, the NW schedules a NSA UEs switches between LTE UL and NR UL in a TDM way. The NW can indicate UE (on the LTE UL side) to follow a LTE TDD-FDD CA timing (case 1 timing). To cooperate single Tx operation, NR defines "difficult" band combinations for NSA case. In principle, if two or more band combinations have IMD2 or IMD3 (L-L or H-H), it will be classified as "difficult" band combinations. UE will report the per band combination capability bit to the network when the band combination is regarded as difficult. The bit applies to all fallback BCs that are defined in RAN4 as problematic BCs. If a UE reports that the specific band combination is problematic, it means a UE can only be scheduled single Tx when channel allocations are also difficult; otherwise, the UE behavior is undefined. Here, the channel allocations refer actual UL transmission gNB/ eNB schedules through UL grant. The difficult channel has same definition as difficult band with IMD2 or IMD3. Besides, the reference UL/ DL configuration (0 to 6) and HARQ\_offset (0 to 9) should be configured to UE in case the UE is configured with EN-DC and simultaneous transmission on LTE UL and NR UL is not supported. Besides, the TDM pattern for scheduling could also be exchanged between the eNB and gNB.

For the band combinations RAN4 doesn't identify as "difficult", it is natural for UE to support LTE UL and NR UL simultaneously. The 2 Tx mode will offer the following advantages:

- Higher data rate
- Better scheduling flexibility

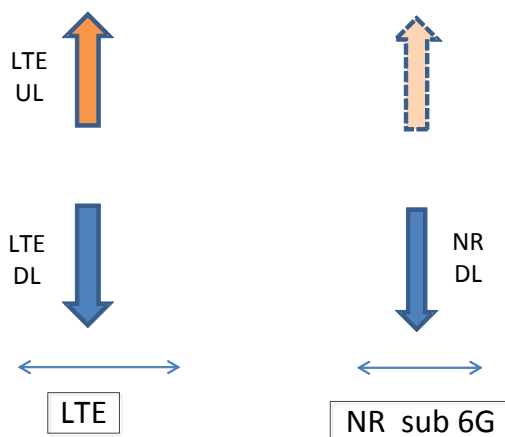

Figure 11-6 Simultaneous NR/ LTE UL transmission (2Tx)

### 11.3 SUL

High frequency band provides massive resource for NR deployments. However, high frequency leads to larger pathloss and smaller coverage. For NR DL, there may be several alternatives to improve the coverage, e.g., larger base station transmit power, massive MIMO. In contrast, UL coverage will be more serious due to the limited transmit power of UE and limited number of transmit antennas. Thus there will be an imbalance between DL and UL coverage.

In order to improve the UL coverage, a lower-frequency carrier can be used for NR UL transmission in addition to NR dedicated UL carrier, where the lower-frequency carrier is a supplementary uplink (SUL).

A typical deployment is that NR carrier is on 3.5GHz and SUL is on 1.8GHz, where DL and UL are expected to achieve comparable coverage.

In addition to data transmission, SUL can be used for initial access. UE can choose SUL or NR dedicated UL to access the network based on its measurement and NW's configuration.

Table 11-6 3GPP operation bands for SUL

n80	1710-1785 MHz
n81	880-915 MHz
n82	832-862 MHz
n83	703-748 MHz
n84	1920-1980 MHz
n85	2496-2690 MHz



To effectively support SUL operations, there will be more requirements for UE implementation, e.g.:

- Different RF chains: As the main motivation of SUL is to improve UL coverage, the SUL and NR dedicated DL/ UL are usually in different frequency bands. Depending on the specific band combination, UE may need two different RF chains, each of which is for one frequency band.
- Synchronization of two UL chains: The PHY scheduling depends on various types of timing, thereby requiring synchronization of two UL carriers/ chains.
- Dealing with different numerologies for different UL transmissions.

## 11.4 LTE and 5G NR RF path co-banding

Spectrum allocation in sub-6 GHz, in general, is very scarce and possibly requires co-existence of multiple RAT within the same/ adjacent block of channels. In this section, support for LTE and NR within the same band or block of spectrum is discussed since it is expected to be legitimate scenario. For example, Band 41, 42/ 43 with such large spectrum block can be utilized for LTE and NR in the same band. This requires tight co-operation and interference mitigation amongst LTE and NR. Besides operator sharing band for LTE and NR, different operator may have deployed different RAT within a given band or block of spectrum, and hence could benefit from economies of scale due to sharing the same RF front end architectures between RATs. For example, Operator deploying LTE in Band 42/ 43 may currently face difficulties in terms of cost and availability/ demand. Having other operators requiring to deploy 5G NR using the same band, would result in higher demand for RFFE components and hence larger economies of scale.

This following subsections will look at both scenarios of shared as well as dedicated RAT use for a given spectrum block.

### 11.4.1 Concept and Architecture of RF Path Co-banding

RF path co-banding refers to the scheme of sharing the same RF path (from the transceiver to the antenna) by carriers of different RATs (Radio Access Technologies), which operate with overlapped frequency range. In conventional UE designs, such as case of B1, single Tx RF path can transmit B1 LTE carrier and B1 WCDMA carrier; likewise single Rx path can receive signal for B1 LTE and WCDMA. In 5G NR system, the co-banding concept is applicable for the spectrum of 3.5 GHz as well 2.5 GHz in sub-6GHz range. That means LTE can share RF path with 5G NR working at these frequency bands. As an illustration, the spectrum range of relevant 3.5 GHz bands is as follows:

Table 11-7 3.5 GHz spectrum band

LTE Band number	UL	DL	Duplex mode
B42	3.4-3.6 GHz	3.4-3.6 GHz	TDD

B43	3.6-3.8 GHz	3.6-3.8 GHz	TDD
B48	3.55-3.7 GHz	3.55-3.7 GHz	TDD

NR Band number	UL	DL	Duplex mode
n77	3.3-4.2 GHz	3.3-4.2 GHz	TDD
n78	3.3-3.8 GHz	3.3-3.8 GHz	TDD

Actually B48 is within the frequency range of B42+B43, therefore analysis is focused on the co-banding between NR band n77/ n78 and LTE B42/ B43. A typical RF architecture for 3.5 GHz RF path co-banding is shown in Figure 11-7.

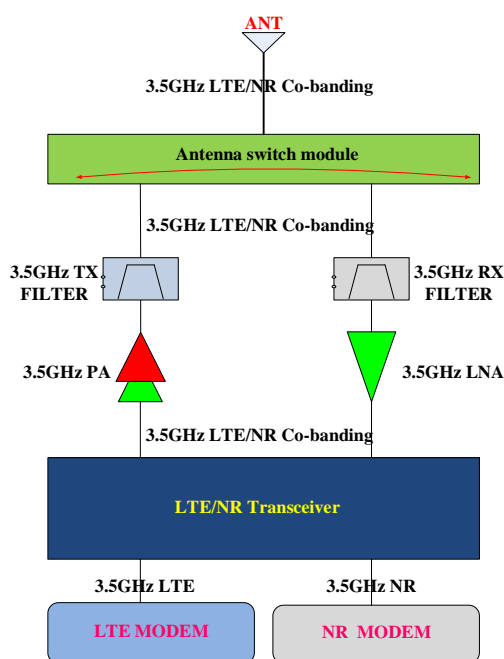

Figure 11-7 3.5GHz typical RF architecture

As shown in Figure 11-6, 4G LTE and 5G NR have separate modem. The co-banding path starts at the transceiver, through PA/ LNA and the same filter/ switch/ antenna. The advantage of RF path co-banding is obvious that the cost and PCB area are saved by sharing the same components, and the UE design can leverage the experience of 4G LTE and 3G WCDMA co-banding. On the other hand, there are plenty of challenges when migrating the design considerations from LTE/ WCDMA co-banding to the LTE/ NR co-banding, for example the increased bandwidth of NR compared to the LTE, the PAPR (Peak to Average Power Ratio) difference of uplink signal, etc., as analyzed in following sections.

### 11.4.2 System-level Challenges

At system level, the main challenges of LTE/ NR co-banding come from the 5G NR requirements. The differences between 5G NR and 4G LTE include:

- Compared to the LTE system with a maximum channel bandwidth of 20 MHz, 5G NR has

a higher maximum channel bandwidth of up to 100 MHz;

- Compared to the LTE system with the uplink carrier of DFT-SC-OFDM, 5G NR is to support both CP-OFDM and DFT-S-OFDM, and there will be a PAPR shift for CP-OFDM modulation on the baseline of LTE DFT-S-OFDM;
- Compared to the LTE system with the maximum RF output power of 23dBm, 5G NR is supposed to output a power up to 26dBm of power class 2.

Therefore the RF-path co-banding design needs to utilize a common path to reach different targets of LTE and 5G NR. A systematic approach is necessary to decompose the RF chain and analyze the impact to key components. The main considerations are presented next.

- Transceiver

A key challenge is to support the bandwidth up to 100 MHz with a single carrier. If the bandwidth of 100 MHz for a NR carrier can be supported, then the bandwidth of 20 MHz for LTE should not be the bottleneck. Furthermore, special attention should be paid to Tx noise/ emission and Rx out of band blocking performance, with broadband filter configured for Tx and Rx.

- Power Amplifier (PA)

Both the channel bandwidth and the wide frequency range will be the challenge. For example, for NR band n77 's frequency range 3.3-4.2 GHz, it is quite difficult for a single PA to cover such a wide bandwidth of 900 MHz, compared to the bandwidth of 200 MHz in LTE B42 or B43. A suggested way is to split the full frequency range into two parts, and apply two PAs to meet the requirements, but this needs more investigations. About the single channel bandwidth, 100 MHz per NR channel requires much wider effective bandwidth possessed by biasing and supply feeding circuits, compared to 20 MHz in LTE case. That also necessitates schemes to mitigate the memory effect and ensure the linearity performance.

The exact maximum output power of 5G NR is to be determined by standardization bodies. Even if targeting at the same level as LTE power class, generating enough output power for such wide NR channel bandwidth is not easy task for the component vendors. Aforementioned 5G NR uplink will use the waveform of CP-OFDM, which has a much higher PAPR than SC-FDMA of LTE, necessitating higher peak power capability of PA. If the PA is specified as same power class for NR and LTE, its power added efficiency (PAE) in LTE mode will normally degrade due to operating away from relevant optimum output power level.

- Filter

In the co-banding scenario of 3.5 GHz LTE/ NR, the total bandwidth of 900 MHz of n77 is problematic for conventional SAW/ BAW filter design. Ceramic technology based filter is considered but the performance of insertion loss and out of band attenuation needs to be balanced. For a single carrier of 100 MHz, the challenge comes from the group delay parameter which typically degrades the uplink EVM performance.

- Low Noise Amplifier (LNA)

The main concern of LNA for 3.5 GHz LTE/ NR co-banding is its gain and noise figure performance, due to the wide frequency range coverage. LNA commonly gets integrated into the transceiver, so this aspect shall be considered into the transceiver design as well.

- Antenna switch module

The power handling of ASM should cover the peak power of NR, which would increase the area, cost and design complexity of the switches. On the other hand, the switching speed need to be faster than LTE to satisfy the NR system requirements.

- Antenna design considerations for LTE/ NR co-banding

NR band n77's bandwidth of 900 MHz is significantly wider and more challenging than n78's bandwidth of 500 MHz; n77 deserves more attention than n78 accordingly. For NR band n77, its relative bandwidth percentage is 24.0%, which is close to the relative bandwidth percentage of 23.7% for the existing and common LTE mid bands ranging from 1710 MHz to 2170 MHz. Therefore, similarly, it should be achievable to enable efficient radiation for n77 by the solution of a single antenna. Besides, two separate antennas covering 3.3-3.8 GHz for n78 and 3.8-4.2 GHz for the rest of n77 respectively connected to the ASM directly and individually can be also the option to meet n77's wide-band requirement with the decent antenna efficiencies. However, when the architecture of two separate antennas is employed, the isolation between the two antennas should hence be taken into design consideration and overall performance balance. Last, no matter the architecture of the single antenna or two separate antennas is used, the risk of antenna isolation should not be ignored compared to the existing LTE architecture and placement because more antennas will be requested by sub-6 GHz 5G communication systems.

### 11.4.3 Way Forward on standalone support

The RF path co-banding of LTE/ NR can better utilize the spectrum allocated globally and reuse the overall UE system architecture for simplification. As stated, there are challenges due to the new requirements of NR quite different from LTE. It will be valuable to investigate more into the system level analysis, component level design and practical implementation so as to achieve good RF performance with the co-banding of LTE/ NR.

### 11.4.4 Co-banding with simultaneous operation

So far, the previous subsections focused on non-shared use of RF front end for a given spectrum block/ band. Another important scenario is support for simultaneous operation of multi-RAT within a given block of spectrum (e.g. 10 MHz carrier split into 5MHz carrier for LTE and 5 MHz carrier for NR). From a device architecture point of view, it may be possible to re-use/ share the same RF front end architecture components/ transceivers across different

RATs within shared spectrum. However, there may be co-existence/ interference concerns if multiple RAT are not synchronized in terms of DL/ UL operation. This would require the device to adhere to in-band RF performance specifications as defined by 3GPP, while maintaining good spectral efficiency. Some of the key requirements are as follows:

- In-band Emission (NR & LTE): Meet SEM requirements. MPR/ AMPR values yet to be defined.
- Adjacent channel selectivity (NR & LTE): 27 dB (LTE) and 33dB (NR)
- ACLR (NR & LTE): 31dB for 20MHz channels. FFS for other CBWs
- Guard band requirement (NR & LTE): FFS in 3GPP
- In-band blocking: FFS in 3GPP
- In-channel selectivity: FFS in 3GPP

Beside these adjacent channel requirements, co-channel deployment of LTE and NR may be possible. This would require sharing in time e.g. use of TDM approach between LTE and NR (using MBSFN subframes). However, this may impact overall system efficiency and such deployment scenario require careful system efficiency and UE performance considerations.

## 12 Demodulation Performance

### 12.1 High Speed Train Scenarios

In some countries, several vehicles move with the speed over 300km/h, e.g., Japan Tohoku Shinkansen (320km/h), German ICE (330km/h), AGV Italo (400km/h), and Shanghai Maglev (430km/h). With the increase of high speed moving environment, the demand of using mobiles is growing larger. Therefore, it is important to guarantee the performance under the high speed scenarios <sup>[11]</sup>.

High speed leads to high Doppler Shift, which may significantly decrease the demodulation performance of UE and affect user experience in the high-speed train scenario. For 5G, the UEs' demodulation performance should meet the relevant requirements of 3GPP in the scenarios where the mobility speed is up to 500km/h. In Table 12-1, we calculate the Doppler shift under different speed and frequency <sup>[12]</sup>. For 3.5GHz, the scope of Doppler Shift is up to  $\pm 1620$  Hz with 500 km/h mobility speed.

Table 12-1 Doppler shift under different speed and frequency

Speed (km/h)	Doppler shift (Hz)		
	1.9GHz	2.6GHz	3.5GHz
100	176	241	324
200	352	481	648
300	528	722	972

350	616	843	1134
400	704	963	1296
450	792	1083	1458
500	880	1204	1620

In order to have better network performance, dedicated network is deployed along the high speed railway. To avoid interference, separate carriers are utilized for dedicated network and public network. To avoid frequent handover, cell combination is applied: multiple RRHs are connected to one BBU with fiber. The coverage of a single cell can be extended significantly, and no handover is necessary within several RRUs belonging to the same BBU. Figure 12-1 shows the dedicated high speed train scenario in our network.

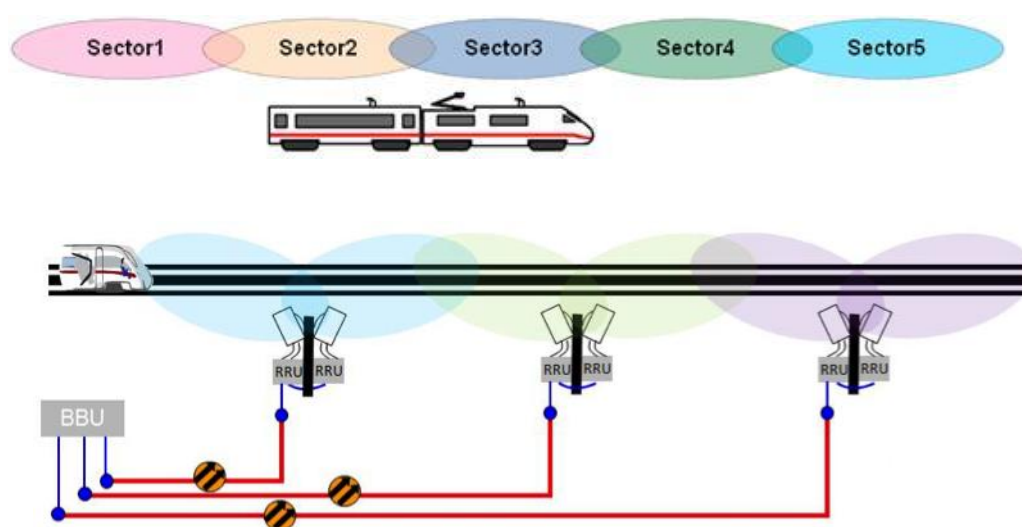

Figure 12-1 Dedicated high speed train scenario

The above high speed scenario has multiple taps. The UEs' demodulation performance should meet the needs of multi-path signals with opposite Doppler Shifts.

The similar scenario has been discussed during LTE Rel.14 in 3GPP RAN4 group<sup>[13]</sup>. The HST-SFN channel model is specified in 3GPP TS36.101 to capture the scenario<sup>[14]</sup>. Advanced receivers have been proposed by different companies to recover the performance loss caused by different Doppler shifts at different channel taps. Most of the proposed methods are to utilize the LTE CRS structure to extract the Doppler shift of each tap and compensate them in channel estimation<sup>[15] [16]</sup>. An example of LTE performance in HST-SFN channel with legacy receiver and advanced receiver is shown below. Legacy receiver shows considerable performance loss in at speed of 350km/h, while advanced receiver is able to recover such loss.

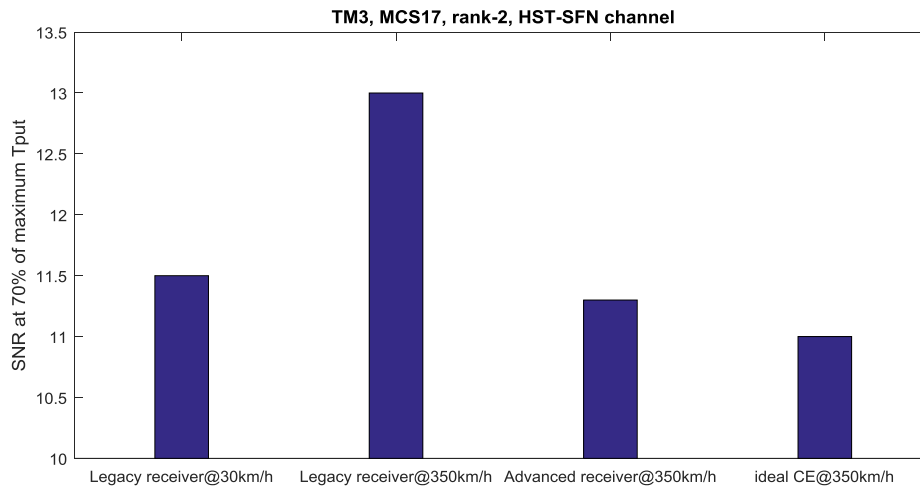

Figure 12-2 An example of LTE performance under HST-SFN channel

The algorithm investigation and performance evaluation for high speed train scenarios may need to be revisited in NR system due to following changes in specification:

- (1) There is no CRS in NR system. Therefore, the estimation of per-tap Doppler shift will rely on other reference signals, e.g., TRS, CSI-RS or DMRS. Due to different structures of those reference signals, the algorithm could become quite different;
- (2) NR supports different DMRS densities for PDSCH channel estimation. The impact of Doppler shift will be different for different DMRS configurations;
- (3) LTE HST-SFN channel targets at speed of 350km/h, while NR targets at speed up to 500km/h. In addition, the carrier frequency of some NR band is higher. Therefore, the maximum Doppler shift is larger;
- (4) LTE only support 15kHz subcarrier spacing, while NR can support different numerologies. With larger subcarrier spacing, the performance is more robust to Doppler shift.

As a summary, high speed train scenario is a changing scenario for demodulation. However, through carefully designed reference signal and receiver algorithm, most of the negative impact can be mitigated. More future studies are needed for NR demodulation.

## 12.2 UE Speed and DMRS Density

Besides high speed railway scenario with dedicated network, the normal vehicles in urban or highway scenarios also suffer from high moving speed. Although the speed could be relative lower than that of high speed railway, the vehicles suffer more from Doppler spread due to richer scattering environment.

The Doppler spread is translated into time variation of the fading channel. In order to estimate such time-varying channel at UE side, gNB needs to transmit known reference signal periodically, which is DMRS in NR for receiving PDSCH. The time distance between two

adjacent DMRS is usually smaller than coherence time to guarantee the channel recovery of all the data symbols, where coherence time is defined as a time period in which the channel does not vary a lot, or more formally, the time correlation of the channel is larger than some threshold. Assuming that the threshold is set to 0.9, we calculate the coherence time and Doppler spread of the channel for different speeds following Jake’s model, as shown in Figure 12-3.

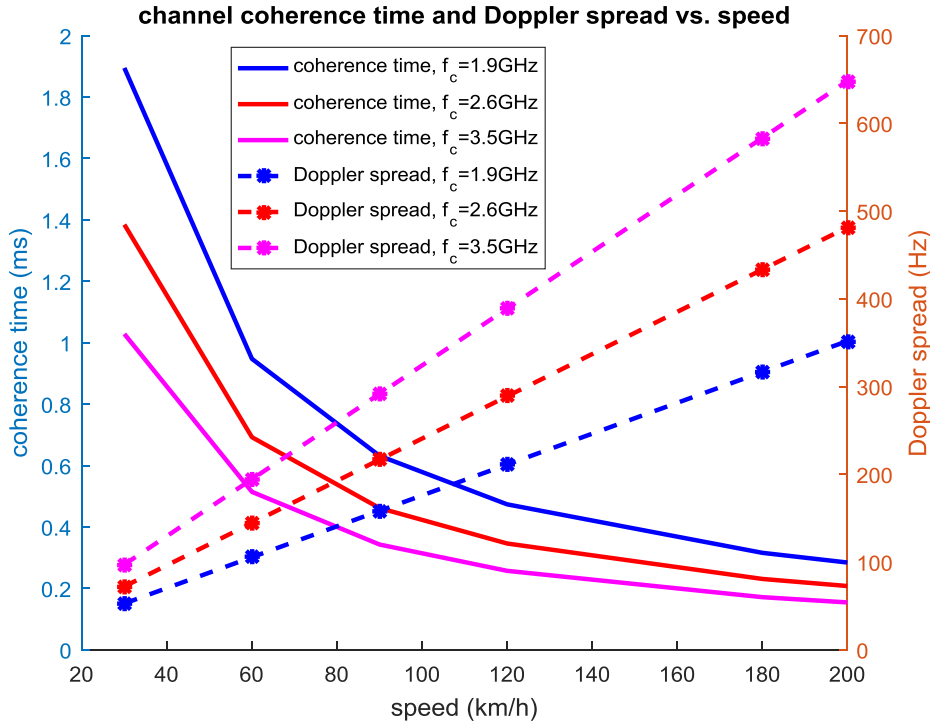

Figure 12-3 Channel coherence time and Doppler spread under different speeds and carrier frequencies

In the previous cellular systems, such as LTE, the time domain density of the reference signal is usually fixed and designed based on maximum moving speed supported. However, in NR system, in order to minimize the DMRS overhead and maximize the data throughput, 3GPP specified different DMRS configurations so that gNB can transmit DMRS with different densities according to scenarios<sup>[17]</sup>. The DMRS overhead and maximum time distance between two adjacent DMRS symbols are summarized in Table 12-3 for some DMRS configurations in 3GPP NR system. In the table, *DL-DMRS-add-pos* is a parameter to specify the number of additional DMRS symbols besides the front loaded DMRS. The DMRS overhead is calculated assuming only two DMRS antenna ports are configured and multiplexed with FD-OCC.

Table 12-2 DMRS overhead and time distance between adjacent DMRS symbols (DMRS configuration type 1, *DL-DMRS-len*=1)

<i>DL-DMRS-add-pos</i>	DMRS overhead (2 ports)	Maximum time distance between two adjacent DMRS symbols (ms)



		SCS = 15kHz	SCS = 30kHz	SCS = 60kHz
0	3.6%	1.00	0.50	0.25
1	7.2%	0.82	0.41	0.21
2	10.8%	0.36	0.18	0.09
3	14.4%	0.21	0.11	0.06

By comparing the time distances calculated in Table 12-2 and the coherence time shown in Figure 12-3, one can tell that for a given numerology, the number of additional DMRS should be chosen dynamically according to UE speed in order to guarantee the channel estimation quality while minimize the DMRS overhead.

The trend is more obviously shown in BLER performance. In Figure 12-4, SNR values that achieve 70% throughput at MCS10 are compared for different numbers of additional DMRS under EVA channel with different Doppler spread. According to the results, 0 additional DMRS is enough for Doppler spread below 30Hz. And 1 additional DMRS is needed for Doppler spread between 150Hz and 300Hz. When the Doppler spread is increased to 600Hz, 2 additional DMRS are needed to optimize the performance. Please notice that when channel estimation quality is not a limiting factor, the throughput performance will be degraded with larger DMRS overhead because the number of RE used for PDSCH transmission is reduced.

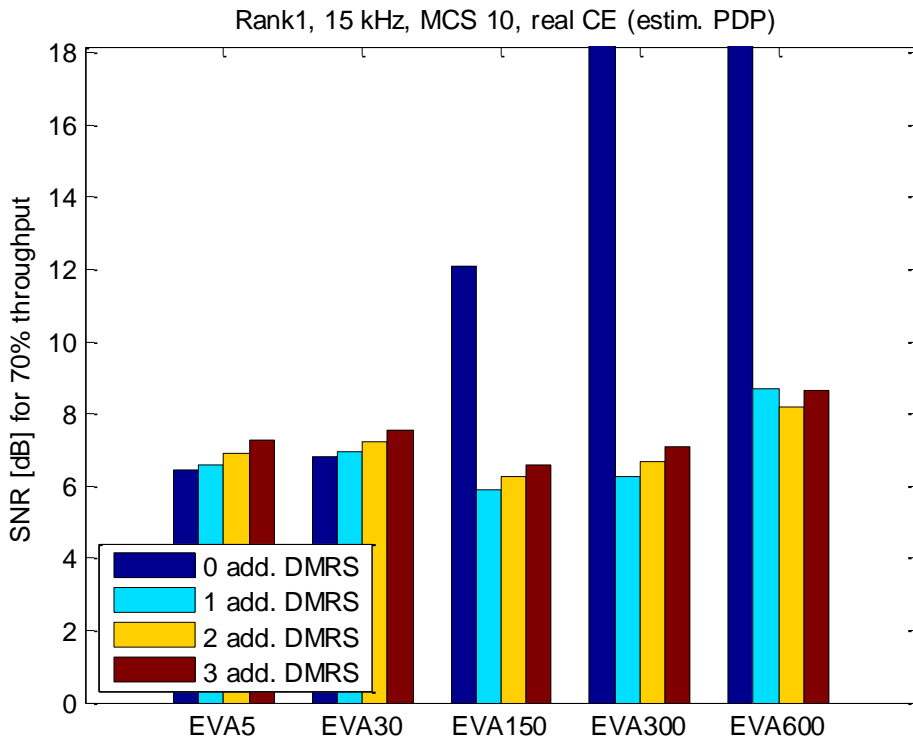

Figure 12-4 An example of NR UE performance with different DMRS configurations under

different Doppler spread

Therefore, in order to maximize throughput, network should configure appropriate number of additional DMRS symbols separately for each UE according to its speed. However, this can only be achieved when network can predict both the speed of UE and channel estimation performance of UE, which makes the ideal adaptive DMRS configuration for each individual UE impractical.

In reality, the DMRS configuration in a network most likely will follow normal UEs' speed in the deployed scenario and some typical channel estimation performance. The UE with speed much lower or higher than the normal speed in such scenario may suffer from performance penalty. Therefore, the robustness of UE performance for different DMRS configurations under different UE speeds should be studied. And the trade-off between UE implementation complexity and target channel estimation performance needs to be carefully considered and aligned to the expected UE performance at network side.

---

## 13 Power Consumption

### 13.1 Introduction

The main topic of this chapter is the changes that we might expect to see in the power consumption of the NR modem compared to its predecessors. In the UE as a whole, significant power may also be consumed in the display and the applications processor, but these will not be considered here, other than to mention that higher data rates in the modem are likely to be accompanied in the UE by higher resolution displays and graphics engines driven by faster applications, and these will also have an impact on UE power consumption.

The modem becomes a significant contributor to the power requirement once connectivity is involved, and can be the dominant user of power when data rates are very high, or when channel conditions are poor. The challenge facing NR is not simply to deliver higher instantaneous data rates, but to ensure that data transfer happens in an energy efficient way whether the average data rate is very high or very low. In this section we will be taking a closer look at the factors affecting the power requirements of the NR modem in different use cases, and some of the ways in which the UE and the network can help each other to ensure that the energy in the UE battery is used as efficiently as possible.

### 13.2 Key scenarios and performance metrics

The power consumption in a UE depends on a number of variable factors, among them the radio environment between the UE and the gNB, user data throughput and usage patterns, quality of service requirements, network coverage provision and user mobility. A user on the edge of a cell will inevitably experience slower throughput and higher power consumption than one who is near a gNB and has a good multipath environment. For a better

understanding of UE power consumption patterns it is helpful to standardise environmental factors as far as possible and look at a few simple scenarios.

### 13.2.1 Maximum throughput

For most UEs, the maximum throughput scenario provides the most energy efficient mode of transferring data, in which the energy consumed for each bit transferred is a minimum. The uplink power will vary with the distance between the UE and the gNB, but when the UE transmit power limit is reached the only way to extend uplink coverage is to concentrate the same energy into fewer bits.

In the NR downlink, increased throughput is provided using higher bandwidth carriers and increasing the number of MIMO layers that are used to transmit data. This reduces the energy per bit, but requires the UE to have more active receive paths and faster processing to deal with the higher data rates, leading to higher UE power at maximum throughput. To compete with earlier generations of UE it is essential to provide a power profile that scales down as the data rate falls. Will a 90% reduction in data rate mean a 90% reduction in power consumption?

### 13.2.2 The power vs latency trade-off

Sadly the answer is no, but some new features introduced for NR can help move towards this target. Bandwidth part adaptation can reduce the volume of data that the UE has to process when maximum throughput is not needed. Cross-slot scheduling can be used to eliminate unnecessary capture of the data channel in slots where no data is present for the UE, for the price of only a small increase in latency. Used in combination, these two features can reduce the energy cost of control channel monitoring, by restricting the control channel for a UE or group of UEs to a narrow bandwidth part which can be decoded more quickly. In many common low data rate use cases control channel monitoring can consume more power than data transfer, so this can lead to significant power reductions.

Where the latency requirement can be relaxed, DRX allows further power savings. This will reduce the active duty cycle for control channel-only monitoring, and if cross-slot scheduling is active then data channel reception is only needed when UE data is present, so that data channel processing power truly scales with Tx and Rx data rates. With this configuration the modem might spend 90% of its time in a low power sleep state, with corresponding power savings, but the penalty would be substantially increased latency – perhaps several 10's of milliseconds. For many popular applications (social media, YouTube, file transfer....) strict low latency is not a user requirement, and most users would find this a price worth paying for increased battery life.

### 13.2.3 Achieving power efficient VoNR and ViNR

Today's UEs (2G, 3G or 4G) claim talk times of up to 30 hours for voice calls, and setting this against the typical battery capacity this equates to an average power consumption of around

300-400mW. When moving from LTE to NR it is important to remember that the energy cost of processing one TTI at 100MHz will be higher than the cost of processing a TTI of the same duration at 20MHz, even though the energy per bit will be lower. Shorter NR TTIs will help in this respect, but the key to low power consumption for NR voice will be to keep the data that the UE has to process for a voice call to a minimum.

With NR, a single TTI at full bandwidth might deliver 1Mbit of data, so that 1 active TTI every 20ms would be enough to sustain a high definition video connection. For a voice-only call, where the speech frame might be 250 bits or less, it will be much more efficient to use a narrow bandwidth part to transfer the data.

### 13.2.4 TDD spectrum and NR UE power consumption

Fortunately for the first generation of NR UEs, most of the high bandwidth spectrum under 6GHz is found in TDD-only bands. This results in a tradeoff between uplink and downlink data rates, but it also means that receive and transmit will not both occur at the same time, reducing both the peak and the average power requirement in the UE. The effect of this will be seen in more detail in section 13.3.6.

### 13.2.5 Scheduling implications

The preceding examples illustrate how some of the key features of NR can be used to adapt UE behavior so that power efficiency can be optimised to deal with the traffic that is present. Cross-slot scheduling allows more efficient use of the physical receive and transmit resources in the UE. Bandwidth part adaptation means that irrelevant resource blocks can be excluded from the sampling process, resulting in a lower processing load, and DRX allows appropriate tradeoffs to be made between power consumption and latency.

In practice a single UE can carry several different types of traffic concurrently, and a fully optimised solution may require unacceptably high levels of signaling, or be beyond the capabilities of existing scheduling algorithms. The improvements that have already been made for NR include many of the building blocks that are needed to improve power efficiency - it will be up to network operators and UE manufacturers to use them wisely.

## 13.3 Power scaling from LTE to NR

Since commercial NR devices are not yet available for testing, it is helpful to examine the power consumption characteristics of LTE UEs in order to estimate what NR power requirements might be. Initially we will be looking at the UE under conditions of maximum power consumption and maximum throughput - methods for reducing UE power consumption when the data rates are lower will be considered in the next section. The analysis will be based on a figure of merit (FOM) defined as

$$FOM = \frac{UE \text{ maximum power}}{UE \text{ maximum downlink data rate}}$$

The uplink data rate is not included in the figure of merit calculation, as power in the uplink is determined primarily by the transmit power at the antenna, which can be a maximum even at low data rates under poor channel conditions. The effect of uplink configuration on UE power consumption is considered separately in section 13.3.3.

### 13.3.1 Example power breakdown for an LTE UE

Figure 13-1 below shows a power breakdown for a Cat4 LTE UE in 2013 <sup>[20]</sup> and compares it with typical data taken from present day UEs. Over a 4 year period, design improvements and smaller process geometries and have resulted in significant power savings in the modem, display and applications processor, but at the same time higher throughput from carrier aggregation has increased the processing load, cancelling out many of the savings as the price for increased capability. Maximum power consumption for a Cat16 LTE UE with 1Gbps downlink can exceed 5W (5nJ/bit at peak data rate for the previously discussed figure of merit).

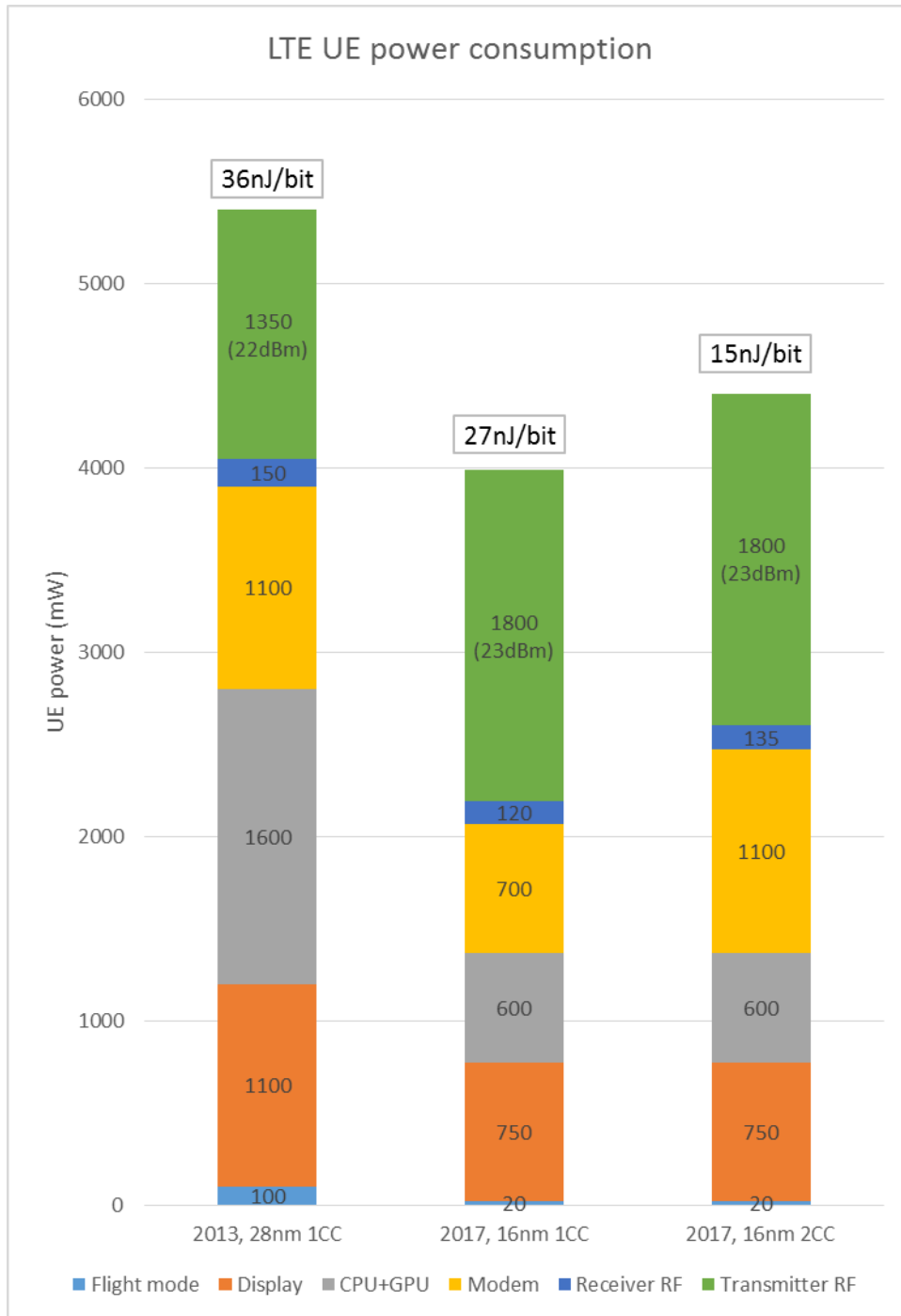

Figure 13-1 LTE UE power consumption

Adding extra carriers increases the total UE power consumption, as there is more data to process, but it also reduces the energy cost per bit. NR uses fewer carriers for a given aggregate bandwidth, but at the same time it increases the quantity of data that can be carried in that bandwidth. It is therefore of interest to consider how the power in different parts of the UE might scale with the move to NR and an additional 4 to 5 times increase in data rates.

### 13.3.2 A simple power model for the NR UE

In order to understand how UE power consumption can be optimised, it is helpful to have a model of how that power consumption is distributed among different subsystems that make up the UE. In accordance with Einstein’s principle, the model should be “as simple as possible, but no simpler”, capturing the main features of UE behavior while avoiding unnecessary detail. Figure 13-2 below shows the basic elements of the model.

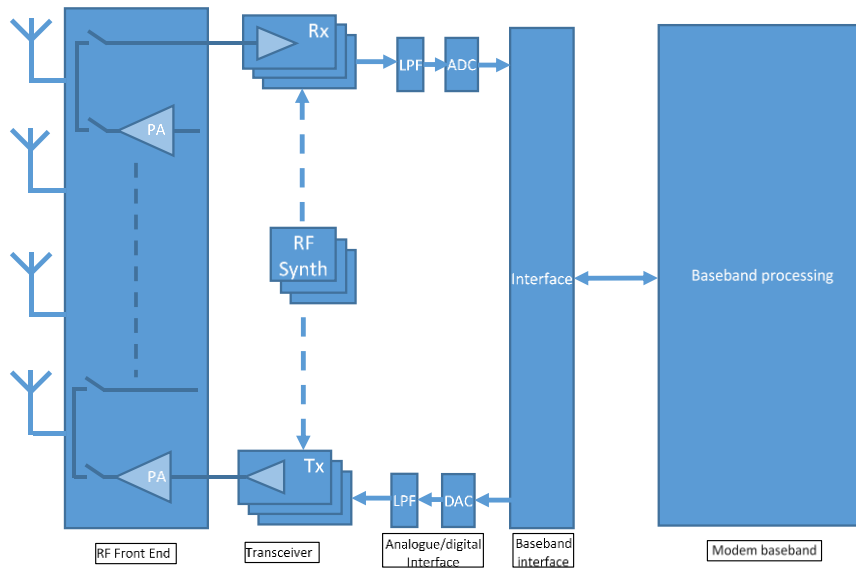

Figure 13-2 Simplified UE block diagram

Subsequent sections will examine how the power in each of these elements is expected to change with the move to NR.

Applications and graphics processor power are assumed to be unaffected by modem data throughput. Power in the applications processor results mostly from accessing applications and data that are already stored in the UE, and the additional processing load for transferring data between storage media and the air interface is typically small in comparison. Similarly, graphics processing power results primarily from servicing the UE display, and is not significantly affected by changing the source of the displayed data.

### 13.3.3 RF front end power

Maximum power consumption in the RFFE is determined primarily by the total RF power transmitted by the UE. This subsystem provides the signal routing between the UE antennas and the receivers and transmitters, and also contains the power amplification for the uplink.

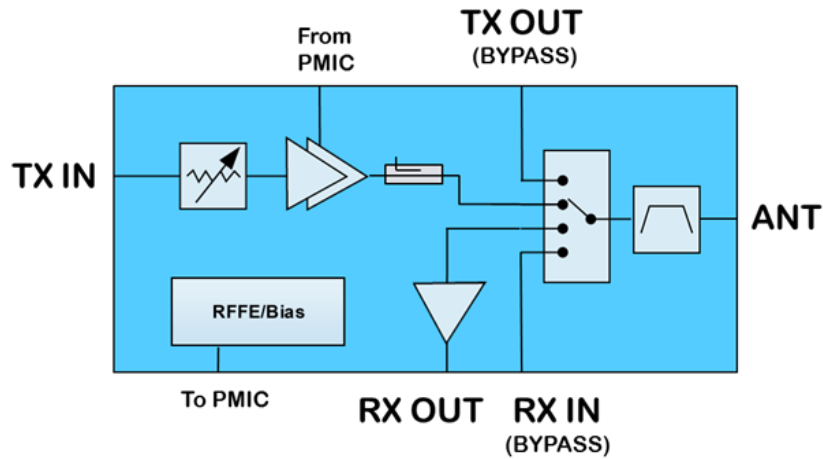

Figure 13-3 RF front end module block diagram

Power amplifier efficiency losses, and RF losses in this module and its interconnect, have a significant impact on the UE energy requirement when it is transmitting at maximum power, because the losses are typically several times bigger than the RF power transmitted. The power required from the battery is therefore significantly higher than the radiated power. Although there can be multiple transmitting antennas, regulations limit the average transmitted power to 23dBm (200mW radiated) in total at the antenna(s). In TDD mode, the instantaneous power is permitted to exceed this figure as long as the average power limit is observed – for example 26dBm (400mW radiated) on a 50% Tx duty cycle, or 28 dBm (670mW radiated) on a 30% duty cycle. An upper limit of 26dBm is likely in the first implementations.

The wider bandwidth of NR compared to LTE increases the peak to average power ratio (PAPR) of the transmitted signal, and makes it harder to achieve the same battery-to-antenna efficiency as an LTE front end. Current estimates suggest that for a single PA supplying an average transmit power of 23dBm at the antenna, the power from the battery will be around 2.5W, compared to around 1.8W for current LTE UEs (Figure 13-1).

For the NR UE, the power required from the battery will vary depending on how the total power is distributed between different transmit antennas, and whether instantaneous power is increased to match the TDD duty cycle. Table 13-1 below gives an indication of the expected variation in battery power for a single power amplifier at different transmit power levels.

Table 13-1 Single PA battery power as a function of transmit power

Tx power at antenna (dBm/mW)	Power from battery (mW)
23/200	2500
20/100	1800
17/50	1400

These examples illustrate that the PA efficiency falls as the output power is reduced – battery power is 12.5 times higher than transmit power at 23dBm, but 28 times higher at 17dBm.



For a given aggregate output power level the efficiency will therefore fall as the number of active power amplifiers increases.

Two independent power amplifiers are needed for 2x2 MIMO on a single carrier, but if two carriers share the same frequency band (intra-band CA), the same pair of PAs can be used for both carriers. With 2 carriers on different bands (inter-band CA), 4 PAs are needed for 2x2 MIMO configuration. Table 13-2 shows the effect of different UE configurations on battery power in the RFFE.

Table 13- 2 Battery power in the RFFE for different UE configurations

UE configuration	Class 3 (23dBm Tx power)		Class 2 (26dBm Tx power)	
	Active PAs	Battery power (mW)	Active PAs	Battery power (mW)
1CC, 2x2 UL MIMO	2 @ 20dBm	3600	2 @ 23dBm	5000
2CC intra, 2x2 UL MIMO	2 @ 20dBm	3600	2 @ 23dBm	5000
2CC inter, 2x2 UL MIMO	4 @ 17dBm	5600	4 @ 20dBm	7200

Comparison of Table 13-1 and 上方 Table 13-2 shows that for a given total transmit power there is significant increase in battery power as the number of active PAs is increased, and that this increase is greater for inter band CA than it is for intra band CA. However, the increase in battery power is generally accompanied by reduced transmission time, as the throughput increases with diversity gain or additional MIMO layers. If the increase in throughput is proportionately greater than the increase in battery power then there will be a net energy saving, but this tradeoff will depend on channel conditions - optimizing the efficiency of the connection may require negotiation between the UE and the network.

When the UE is close to the gNB and transmit power can be reduced to low levels, the front end power contribution can reduce significantly – perhaps 50mW battery power for 0dBm (1mW) transmit power. Uplink power is then dominated by the transceiver contribution (see next section).

Subsequent examples assume that intra-band CA is in operation where there is more than one active carrier.

### 13.3.4 Transceiver subsystem power

Transceiver power consumption is a function of the number of ADCs/ DACs, receivers, transmitters and synthesisers that are active, and this in turn depends on the number of active carriers and the transmission modes employed on each. For each independent carrier that is active in the system, an RF synthesiser is needed to tune to the centre frequency – an FDD carrier would require two synthesisers, as the uplink and downlink operate concurrently at different frequencies. Multiple receivers or transmitters on the same carrier can share the same synthesiser, so MIMO/ diversity operation only affects the number of receivers or transmitters. Finally, each receiver needs 2 RxADCs and each transmitter 2 TxDACs to process I and Q data samples. The number of resources needed can multiply surprisingly quickly, as shown in Table 13-3 below.

Table 13-3 Transceiver requirements for different UE configurations

Mode	BW (MHz)	Carriers	Synths	DL MIMO	Rx	ADC	UL MIMO	Tx	DAC
LTE FDD	20	1x20	2	2x2	2	4	1x1	1	2
LTE FDD	100	5x20	<=10	2x2	<=10	<=20	2x2	<=10	<=20
NR TDD	100	1x100	1	4x4	4	8	2x2	2	4
NR TDD	100	1x100	1	8x8	8	16	4x4	4	8
NR TDD	200	2x100	2	4x4	8	16	2x2	4	8

The transceiver power is therefore a function of the number of active carriers and the number of MIMO layers supported on each, and so the ways in which resource blocks are allocated to carriers and transmission modes are configured can have a big effect on transceiver power consumption. Cross-slot scheduling can greatly assist the UE in ensuring that the full complement of resources is only turned on when there is relevant data to process.

The power requirements of receivers, transmitters and synthesisers will be similar for both LTE and NR carriers sub-6GHz, although there will be some increase in NR power due to the increased bandwidth supported. However, the narrower bandwidth of LTE carriers means that greater numbers of each are needed for equivalent aggregate bandwidth where LTE is used. This is significant for non-standalone operation – using carrier aggregation on an LTE anchor would lead to less efficient use of battery power in the UE.

ADC and DAC power tends to scale at least linearly with sample rate, and a higher bandwidth carrier must be sampled at a higher rate – four times the LTE sample rate for a 100MHz NR carrier - while maintaining similar resolution. Based on the current state of the art in ADC design <sup>[21]</sup>, the ADC power consumption at the required sample frequency and resolution is expected to increase faster than the increase in sample rate, and so the energy cost of sampling the received signal becomes more significant as the carrier bandwidth increases.

200MHz of NR bandwidth at 4x4 DL MIMO is needed for 4Gbps throughput. The Table 13-3 resource allocation can be used with 30 kHz and 60 kHz subcarrier spacing, but for 15 kHz subcarrier spacing the FFT size limits the widest supported carrier to 50MHz and so 4 carriers would be needed for an aggregate bandwidth of 200MHz, doubling the number of transceiver resources from the table. Achieving the required antenna isolation for MIMO operation at sub-6GHz frequencies may limit the number of independent antennas that can be offered in small-footprint devices. This in turn would restrict the total number of transmitters/ receivers that could be supported.

Taking these factors into account, the receive path power requirement for 4x4 MIMO configuration is expected to be around 200-250mW per 100MHz carrier. 2x2 MIMO in the uplink means that fewer transmitters are needed, but the input power required at the RFFE for maximum output means that the power per transmitter will be higher than per receiver. Transmit path power is therefore expected to be around 150-200mW per 100MHz carrier.

### 13.3.5 Baseband processing power

The baseband processing requirement for NR will be defined by the increase in data throughput, and by any changes in signal processing complexity. Downlink processing is more complex than uplink processing, as it has to deal with the effects of noise and channel imperfections in the received data, and so accounts for the largest proportion of baseband power consumption. Uplink and downlink data also pass through the UE memory subsystem, and the resulting memory traffic at high data rates can be a significant contributor to the power requirement. Table 13-4 below shows how the data rates at the baseband input and output vary between LTE and NR in the uplink and downlink. A 2x100MHz NR configuration has to process almost 30Gbps of sample data for a combined uplink/ downlink throughput of 6Gbps, while a 5x20MHz LTE configuration would process 9Gbps of sample data for a combined throughput of 1.4Gbps. On an equivalent silicon process, assuming similar complexity, we might expect NR baseband power to be 3-4x that of a Cat16 LTE UE.

The move from LTE to NR makes complexity changes in both directions, although the net result is expected to be beneficial. The increase in maximum FFT size from 2048 to 4096 means a slightly more than 2x increase in the cost of this operation, and the move to higher order MIMO will also require additional computation when calculating channel estimates. These increases are balanced by a significant decrease in complexity in other areas, such as replacing turbo coding with LDPC coding for the data channel <sup>[22]</sup>, convolutional coding with polar coding for the control channel, and front loading of reference symbols to assist in early decode, all of which will contribute to reducing the processing load at the highest data rates. How might these factors contribute to the NR UE power consumption?

Table 13-4 Baseband throughput for different carrier configurations

	Carrier Bandwidth	Sample rate per layer	MIMO layers	Bits per IQ Sample	Sample Mbps per carrier	Data Mbps per carrier
LTE DL	20MHz	30.72Msps	2	20	1228.8	200
LTE UL	20MHz	30.72Msps	1	20	614.4	75
NR DL	100MHz	122.88Msps	4	20	9830.4	2000
NR UL	100MHz	122.88Msps	2	20	4915.2	1000

The first two columns of Figure 13-1 show that power in the modem/ CPU/ GPU fell from 2700mW to 1300mW between 2013 and 2017. Much of this reduction can be attributed to the smaller process geometry used in the newer UEs - power scaling estimates <sup>[23]</sup> suggest that moving from 28nm to 16nm the expected power reduction would be around 48%, which is in good agreement with the measured results. The third column of Figure 13-1 indicates that adding another carrier increases modem power consumption by 400mW – if this pattern continues for further carriers then a 5CA x 20MHz LTE modem would require around 2300mW.

An NR modem operating over the same 100MHz aggregate bandwidth has 60% more sample data to process (Table 13-4), so its power would increase to 3.7W, with a 2x100MHz configuration requiring 7.4W. However, the first generation of NR modems are likely to use

silicon processes in the range 7-12nm, giving expected power reductions <sup>[23]</sup> of between 25% and 40% compared to 16nm devices. A 30% reduction would bring the 2x100MHz modem power down to 5.2W, and complexity reductions in the NR processing might bring this down further to around 4.5W. Process scaling reductions of around 30% are also expected for the CPU/ GPU component.

### 13.3.6 Standalone NR UE power consumption

The preceding sections have derived approximate power contributions for each of the main UE subsystems, but we still need to account for effect of TDD operation. Values in Table 13-5 below assume a 2x100MHz configuration at maximum throughput with 70% of the time in receive mode and the remaining 30% in transmit mode. Rx-only is assumed to account for 90% of modem baseband processing and Tx for the remaining 10%. Finally, transmit power in the RFFE is assumed to increase to 26dBm to compensate for the shorter Tx duty cycle.

Table 13-5 NR Premium UE estimated power breakdown (standalone)

<b>NR standalone, 2x100MHz, 4x4 DL MIMO, 2x2 UL MIMO</b>				
2x100MHz	FDD power (mW) (Tx 23 dBm)	Rx-only power (mW)	Tx-only power (mW) (Tx 26dBm)	<b>TDD power (mW)70%Rx, 30%Tx</b>
RF front end	3600	----	5000	1500
Rx data path	400	400	----	280
Tx data path	300	----	300	90
Modem BB	4500	4050	450	2970
Display	750	750	750	750
CPU+GPU	420	420	420	420
<b>Total</b>	<b>9770</b>	<b>5620</b>	<b>6920</b>	<b>6010mW</b>

A similar calculation for a 1x100MHz configuration gives a total power of 4340mW. The two configurations are compared in Figure 13-4 below.

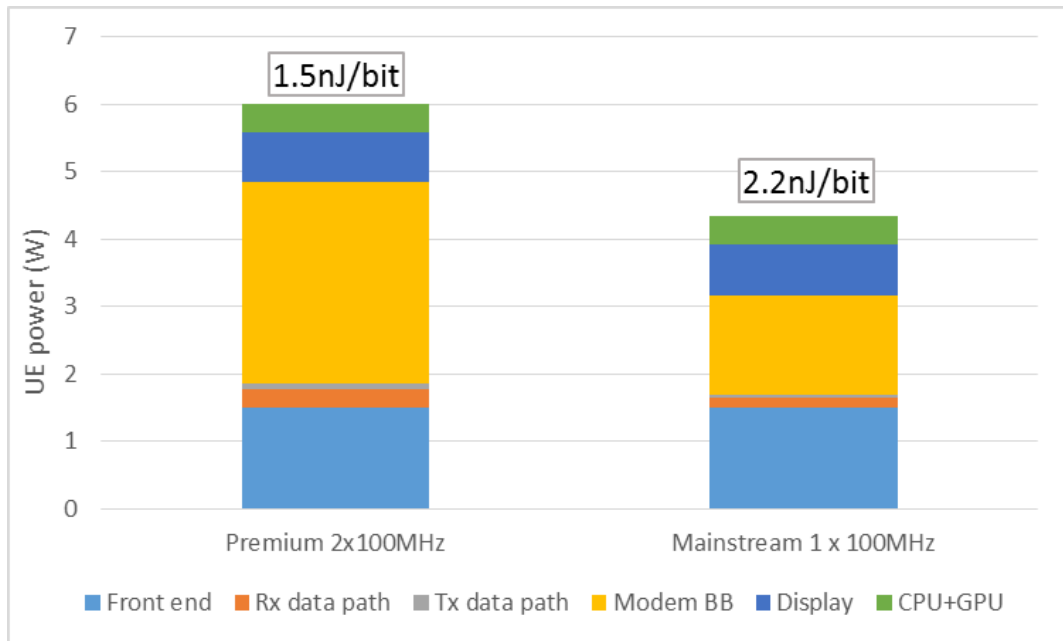

Figure 13-4 Mainstream and Premium UE comparison (standalone)

Intra-band CA for the 2x100MHz case would increase the RF front end TDD power from 6010mW to 6760mW, owing to a loss in efficiency from sharing the transmit power with additional PAs and Tx data paths. The 1x100MHz case would obviously be unaffected.

Adding a 20MHz LTE anchor for nonstandalone operation would increase the Rx/ Tx data path power by 25%, and the peak data processing by up to 5% (200Mbps DL in addition to 4Gbps). This might increase these figures by around 300mW if the anchor is used mainly for mobility management, or 350-400mW if it also carries high volumes of data. The figure of merit for NR UEs of both types is a factor of 10 better than for today's 1 and 2-carrier LTE UEs, but the total power is also higher. Figure 13-4 also shows that for the premium NR configuration at peak throughput the baseband processing power, in contrast with previous generations of UE, requires significantly more power than the uplink transmission. At the below-peak data rates more typically encountered it will be essential to reduce UE power to well below these levels to provide good battery life. Methods for achieving this are discussed in the next section.

## 13.4 Managing UE power efficiently

The simple power model presented here suggests that NR UE power consumption at peak throughput may be higher than for an LTE UE offering lower throughput, but the energy per bit at maximum performance will be significantly better. The key to competitive NR UE performance will be how well the power consumption scales with data rate at lower throughputs. Most users do not currently require sustained high throughput for long periods, and experience with LTE devices indicates that for many typical use cases a significant proportion of UE power is spent monitoring the control channel during periods when user data is absent.

A UE that uses power efficiently needs to turn on receivers and transmitters only when necessary, and to discard any downlink data that is not intended for it at the earliest opportunity.

Power consumption at below-peak data rates is harder to model, as there are many more variables to consider (transport block sizes, modulation & coding schemes, network parameters...). However, a user with an average throughput of 10Mbps in uplink and downlink might expect to see the baseband processing power reduce from the peak level of 2970mW (Table 13-5) to around 600mW, and if located in the middle of the cell would see a reduction in RF front end power from a peak level of 1500mW (Table 13-5) to as little as 50mW. Assuming that the display and applications remain active, this gives a (very) approximate comparison of different use cases summarized in Table 13-6 below.

Table 13-6 Approximate comparison of different use cases

UE Configuration	UE power mW	Figure of merit nJ/bit
Premium UE (2x100MHz), Inter-band CA, 23dBm, Average DL data rate 4Gbps	6220	1.55
Premium UE (2x100MHz), Intra-band CA, 23dBm, Average DL data rate 4Gbps	5590	1.40
Mainstream UE (1x100MHz), no CA, 23dBm, Average DL data rate 2Gbps	3920	1.96
Premium UE (2x100MHz), Intra-band CA, 0dBm, Average DL data rate 4Gbps	4560	1.14
Premium UE (2x100MHz), Intra-band CA, 23dBm, Average DL data rate 10Mbps	3220	322
Premium UE (2x100MHz), Intra-band CA, 0dBm, Average DL data rate 10Mbps	2190	219

The remaining parts of this section discuss some of the ways in which power can be reduced in lower throughput scenarios.

### 13.4.1 Bandwidth part adaptation

The sampling rate in the analogue-digital interface has a direct effect on UE power consumption. If the resources allocated to a particular UE are confined to a bandwidth part which is narrower than the carrier bandwidth, the unwanted resources can be removed by low pass filtering. This allows a lower sampling rate to be used without the risk of aliasing, saving power in the ADCs and DACs at the baseband interface, and saving power in the modem by reducing the quantity of data to be processed.

Bandwidth part adaptation can be used to reduce UE power consumption when the full data bandwidth of NR is not required. Used in combination with cross-slot scheduling, it allows the BWP for the control channel for a specific UE or group of UEs to be narrower than the

BWP for the data channel, reducing UE power consumption in control channel-only TTIs where no data is present. Such cycles can account for over 80% of active TTIs in many use cases.

The expected power saving is not quite in proportion to the bandwidth reduction as there are some fixed costs, but a 50% bandwidth reduction might give 30-40% reduction in modem power.

### 13.4.2 Cross-slot scheduling

In LTE, the downlink assignment has always been sent in the same TTI as the associated data. NR introduces the possibility of cross-slot scheduling, where the assignment can refer to the next TTI, or a later one <sup>[19]</sup>. This can help the UE to save power in two ways – firstly, in control-only periods, it can turn off its receivers as soon as the control channel symbols have been captured without waiting for the decoding result, and secondly, the control channel can be transmitted over a reduced bandwidth part, allowing the UE to sample and process at a lower rate for those TTIs in which the data channel is not needed. The combination of these two features means that receiving the control channel can be much more power efficient, and full bandwidth reception and processing are only needed when there is actually data present. As an additional benefit, if the data allocation can be confined to a smaller bandwidth, it too can be received using a reduced bandwidth part. The penalty is an increase in latency of at least one TTI, but since NR can accommodate shorter TTIs than LTE, sub-1ms latency is still achievable. This is illustrated below in Figure 13-5, the upper graph showing the UE power profile with same-slot scheduling and the lower graph showing the savings that result when cross-slot scheduling is enabled.

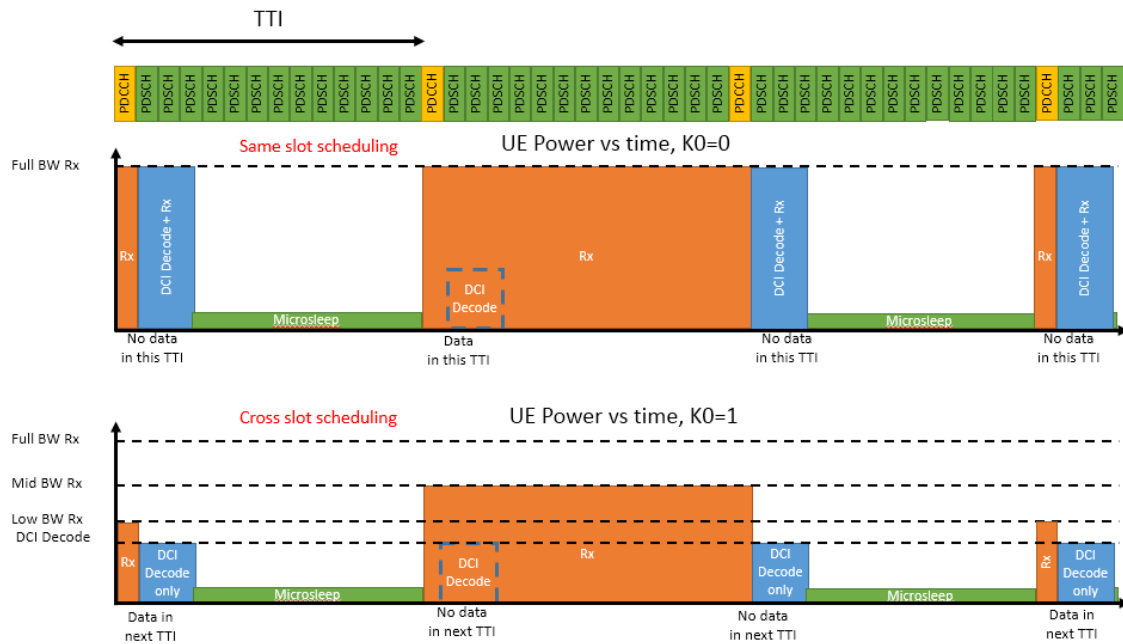

Figure 13-5 Power saving from Cross-slot scheduling

Cross-slot scheduling also allows bandwidth part savings to be made on the data channel,

with receive and transmit resources only being enabled for the resource blocks that have been allocated. This can be particularly advantageous for data traffic consisting mainly of small packets, where receiving and processing over the full channel bandwidth may require disproportionate levels of power. The network can assist the UE in this respect by scheduling the UE resource block allocation appropriately, confining it to narrow bandwidth parts wherever possible.

### 13.4.3 Power vs data rate

With these features in place, power consumption for the UE then consists of two main components, illustrated in Figure 13-6 below. The first is a baseline power level for control channel monitoring, which can be further reduced if the network sets a DRX cycle which is compatible with the latency requirements of the traffic. The second is a data component which is much more closely related to actual volumes of data traffic, and scales well as the data rate changes. For NR to be fully competitive across all data rates, we need both the baseline power level and the slope of the data component to be better than for LTE.

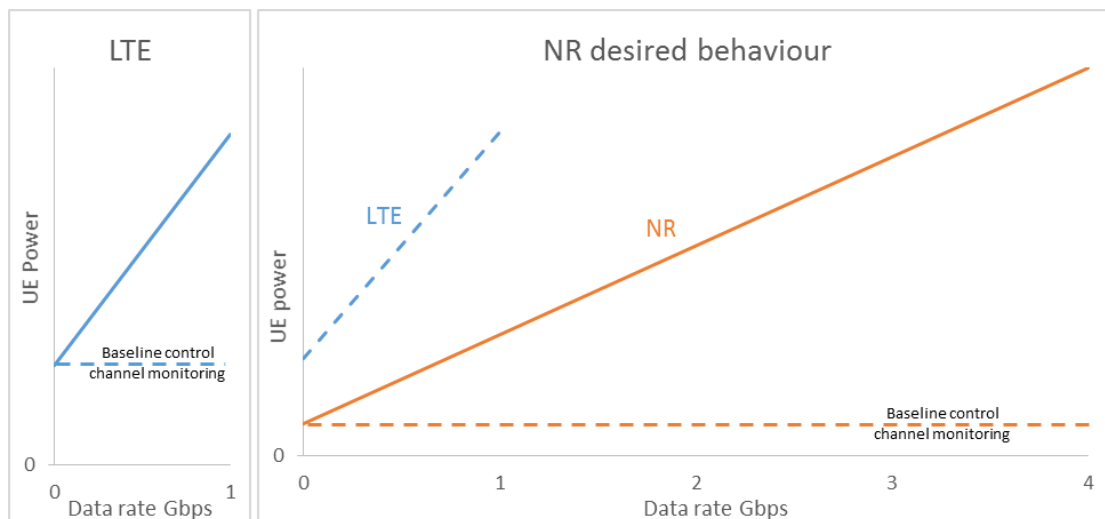

Figure 13-6 UE power variation with data rate

The behaviour illustrated can be applied equally well to uplink or downlink data. The baseline power intercept at zero data throughput is set by the control channel monitoring power, which is a function of the DRX cycle, channel bandwidth and channel conditions. The maximum data rate in the downlink is set by the aggregate bandwidth, transmission mode, coding rate, modulation scheme and the channel conditions, which also determine the downlink power at the maximum data rate. The maximum data rate in the uplink is also determined by these parameters, but may be further limited by the maximum power that the UE can transmit.

The power relationship is, however, not perfectly linear, because data is generally unevenly distributed over successive TTIs. Bandwidth part adaptation can reduce power in those TTIs where the full complement of resource blocks is not used by the UE. The shared objective of the UE and the network should be to keep the baseline as low as possible and to minimize



energy consumption on a per-TTI basis.

#### 13.4.4 Overtemperature protection

6W power consumption is manageable in small bursts, and with good channel conditions a 500MB file transfer could complete in 1 second at 4Gbps. However, if channel conditions are poor the achievable peak data rate drops significantly without a matching reduction in the processing load. If this level of power consumption is sustained for long periods then overheating is possible inside the UE, although this scenario should be rare.

A UE experiencing overtemperature during prolonged high throughput must have options to reduce its power consumption in a controlled manner without losing connectivity. Under such circumstances it can request a temporary performance restriction from the network to allow its temperature to return to more normal levels. This restriction could be in the number of active carriers, the MIMO order, the bandwidth, the duty cycle or a combination of these – each would have the effect of reducing either the number of active resources in the transceiver, or the data bandwidth crossing the baseband interface, leading to a reduction in power consumption.

#### 13.4.5 Periodic PDCCH monitoring

For some popular services like Wechat and web browsing and so on, there are large amount of PDCCH only cases where UE monitors PDCCH but no grant is for the UE. The power consumption of PDCCH-only monitoring is even larger than the power consumption for PDCCH monitoring with grants. Periodic PDCCH monitoring can be used to reduce the PDCCH monitoring of PDCCH only case. This mechanism is supported in R15 and can be configured in a semi-static fashion. The PDCCH monitoring periodicity and offset can be configured to align the data arrivals of one service as much as possible.

### 13.5 Implications for NR UEs

The analysis presented here is approximate, but it still allows us to draw some useful conclusions.

#### 13.5.1 Better efficiency, but higher peak power

Firstly, it seems likely that, at least for the first generation NR devices, a UE operating at 2Gbps will require more power from its battery than an LTE UE operating at 1Gbps or below, simply due to the increased processing requirement. However, if the two devices operate at comparable data rates, the NR UE will require less power, since it will have fewer receive and transmit resources active for less of the time, and there will be efficiency gains in the baseband processing.

## 13.5.2 Standalone vs Non-standalone

In principle a standalone UE should consume less power than a non-standalone UE, requiring fewer receive and transmit resources for equivalent bandwidth. However, if both cases use an anchor carrier in the lower frequency bands for improved coverage, the anchor bandwidth would probably be significantly lower than 100MHz whether it was NR or LTE, and this would tend to reduce any differences.

It is estimated that adding an LTE carrier to an NR standalone UE would increase its power consumption by 5-10% (300-400mW) in a high throughput scenario. However, there is an additional factor which could make the non-standalone percentage increase greater at lower throughputs. If the LTE and NR carriers are unsynchronized, then DRX wakeups for each RAT would occur at different times, reducing the time that the modem can sleep. This would have a large impact on non-standalone power consumption in connected DRX mode.

Synchronizing DRX wakeups between LTE and NR will make NSA operation more power efficient, and should ensure that the power penalty for NSA operation does not exceed 5-10%.

## 13.5.3 Downlink processing may use more power than uplink transmit

At the highest throughputs, the processing power in the NR downlink is likely to exceed the uplink transmit power, which has historically been the dominant component of UE power consumption. Thermal problems can occur if high throughput is sustained for long periods.

Silicon processing advances continue to deliver improvements in power consumption, but at an increasing cost. The power requirement for downlink processing will reduce over time, although history suggests that future bandwidth increases will continue to present challenges for battery technology and thermal management in the UE.

Since average transmit power is limited by RF regulations, and the total carrier bandwidth is increased, there will be less energy per uplink subcarrier in the NR bands than in the LTE bands. TDD operation in the NR bands will allow the PA to increase its peak power output within defined limits, but denser base station deployment is a preferable way to enable high uplink data rates without excessive power consumption.

## 13.5.4 Maintaining efficiency at low data rates

For many applications in common use, data packets are small and relatively infrequent, and control channel monitoring can form a significant proportion of UE power consumption. The energy cost of processing a single TTI at maximum bandwidth may be greater for NR than it is for LTE, but can be reduced for small transport blocks using bandwidth part adaptation. Cross slot scheduling can eliminate the need for speculative reception of the data channel

during the control channel decoding period, and DRX provides a means of trading latency for further power reductions. Each of these options requires cooperation between the UE and the network to maximize connection efficiency by adapting resource allocations to data traffic patterns.

Many of today's use cases can be accommodated comfortably if the user has reliable access to a 50Mbps data bandwidth, even allowing for the impact of high definition video on bandwidth requirements. NR must deliver similar or better power consumption compare to existing solutions in order to meet user expectations. Users will appreciate the benefits that gigabit bandwidth can deliver in terms of response times and file transfer speeds, but the single-user applications that stretch the capabilities of a multi-gigabit connection are still to be written. Power consumption in NR UEs will need to be competitive for all patterns of data traffic from gigabits per second down to bits per second, and this will require cooperation between networks and UEs to match UE resource allocation to data traffic patterns in ways that allow the UE to reduce the data bandwidth that it has to process, and the time for which it is active, so that it can optimize its power consumption. This will be particularly important when competing with established low data rate services such as voice telephony.

UE manufacturers and network operators have a common interest in ensuring that the NR ecosystem can maximize battery life for all of its users, whatever their patterns of use. Networks that take full advantage of the new features that NR offers to optimize UE power consumption will gain a competitive edge, benefitting from more satisfied customers and increased revenues per user.

---

## 14 Test Requirements

With the implementation of 5G over the next decade, device manufactures will face new challenges in testing their hardware, software, and end-to-end deployments. 5G technology, as currently envisioned, is quite different from 4G and will bring together some of the most challenging aspects of existing test approaches and test equipment. It will also introduce new challenges, requirements and risks described further here.

### 14.1 Test areas for 5G sub-6G and challenges

Test solutions must evolve and adapt for 5G, effectively handling the three major use cases identified by 3GPP. It is obvious that 5G is not going to have a monolithic, one-size-fits-all deployment, and any test area, equipment and approach must reflect this. There will be very different requirements with regard to bandwidth, latency, radio characteristics, energy use and mobility.

#### 14.1.1 Test challenges

Traditional device characterization in lower frequency devices has been limited to narrow band and Continuous Wave (CW) modes, but now it is expected that wide band modulated

characterization of devices is required to ensure the device technology suitable for the new 5G waveforms. High bandwidth place challenging demands on components such as filters, mixers, power amplifiers and antennas that are used in mobile devices. To efficiently and reliably characterize these components, measurement systems must offer wide frequency coverage, high dynamic range, high output power, signal stability and signal quality with as little distortion and as few harmonics as possible.

### 14.1.2 Requirement for test equipment

Technological innovations combined with close and trustworthy customer relationships requires innovative test and measurement solutions that allow customers to launch their products more quickly, safely and economically.

Test equipment should be capable to generate and analyze wideband signals. Power amplifiers are crucial to link performance. By using CW and modulated stimuli to characterize power amplifiers (PA) in detail, test equipment should efficiently determine amplifier KPIs such as EVM, AM/ AM plus AM/ PM conversion and gain compression from a single measurement.

Besides providing sufficient measurement accuracy, test equipment need to keep the test cost low enough to meet the demands. Today's market requires test solutions that address legacy technologies, while also supporting numerous verification requirements. Controlling the cost of test is the key attribute.

## 14.2 Device test cycle and test solutions

To develop a new product such as a wireless communication device, it will typically start with feasibility leading to development and implementation phase to commercial quality which will be tested against industry standards and specific customer requirements.

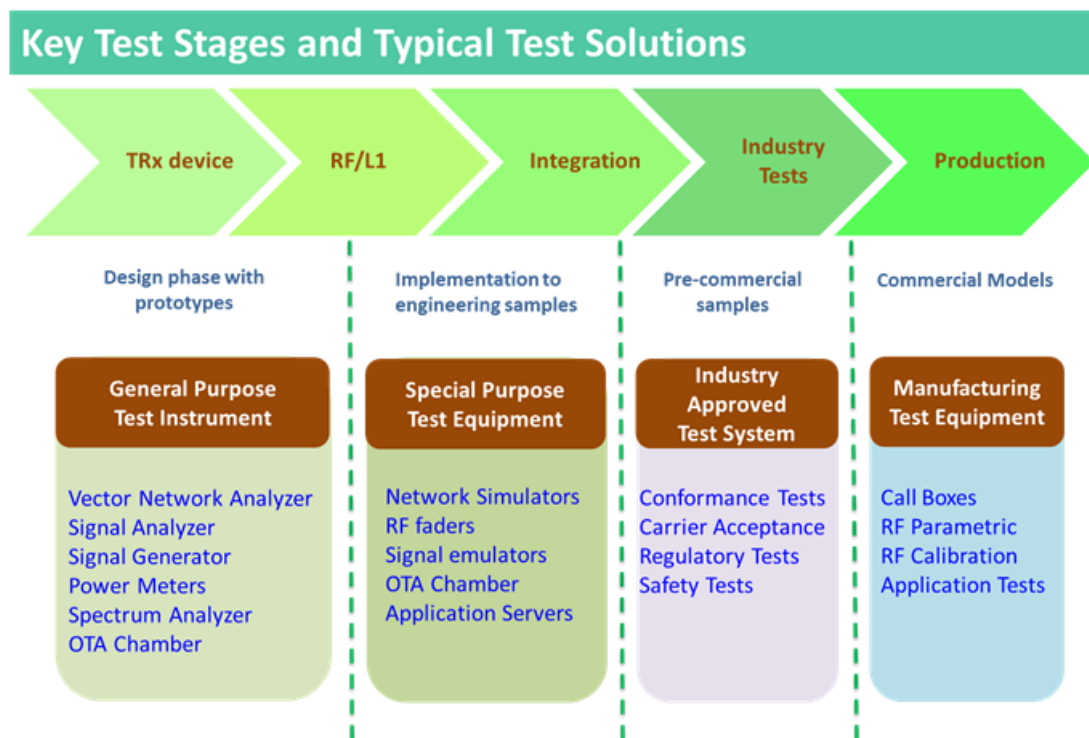

Figure 14-1 Stages of Test solutions

The above diagram illustrates the product development stages and the different test equipment and solutions required for each of the stages.

The initial stages tend to require general purpose test equipment which the test equipment vendors could develop based on the early of 5G requirements such as waveforms, modulations, etc. As the development stages progress, the complexity of the test solutions required would increase. Similar to the device development, the test equipment development would need to closely follow the development of the technical standards of 5G by 3GPP. The testing involved will move from basic tests to more focused tests for the different layers of the protocol.

The entire protocol stack would then be tested in an integrated form which would normally require industry defined tests, such as conformance tests specified by 3GPP RAN WG5 (RAN5). Test equipment vendors would typically work closely with RAN5 and other industry bodies such as GCF to provide test solutions to enable device manufacturers and operators to carry out such tests. In addition, the mobile operators around the world may have additional tests defined as Carrier Acceptance which they would require the device manufacturers to run.

When the new device development is complete and move into production, specific test solutions will be required to check the critical parameters and functions of the products for quality assurance purpose.

### 14.3 3GPP RAN5 Conformance Test

3GPP RAN5 introduced a new work item for 5G Conformance Tests in May-2017. Since then a number of test specifications have been allocated with 38.521-x and 38.523-x as the key ones for RF/ RRM and Protocol tests respectively. Following the latest RAN5#79 meeting in May-2018, the 5G conformance test plan has been updated in R5-182332. The key information from this update is provided in the following sections. The design of the tests is divided into a number of phases aligned with development of the core specifications by other 3GPP working groups. NSA test cases development has started because the core specifications are mostly completed. The start of SA test case development is expected to be in H2/2018.

#### 14.3.1 Target dates

Table 14-1 Targets for each deployment option and phase.

Deliverables		Standalone (SA) Targets		Non-Standalone (NSA) Targets		
Phase #	Label	SA Option 2	SA Option 5	NSA Option 3	NSA Option 4	NSA Option 7
1	Phase 1	RAN5#81 (Nov-18)	RAN5#81 (Nov-18)	RAN5#79 (May-18)	RAN5#83 (May-19)	RAN5#83 (May-19)
1.5	Phase 1.5			RAN5#80 (Aug-18)		
2	Phase 2	RAN5#83 (May-19)	RAN5#83 (May-19)	RAN5#81 (Nov-18)		
3	Phase 3			RAN5#83 (May-19)		

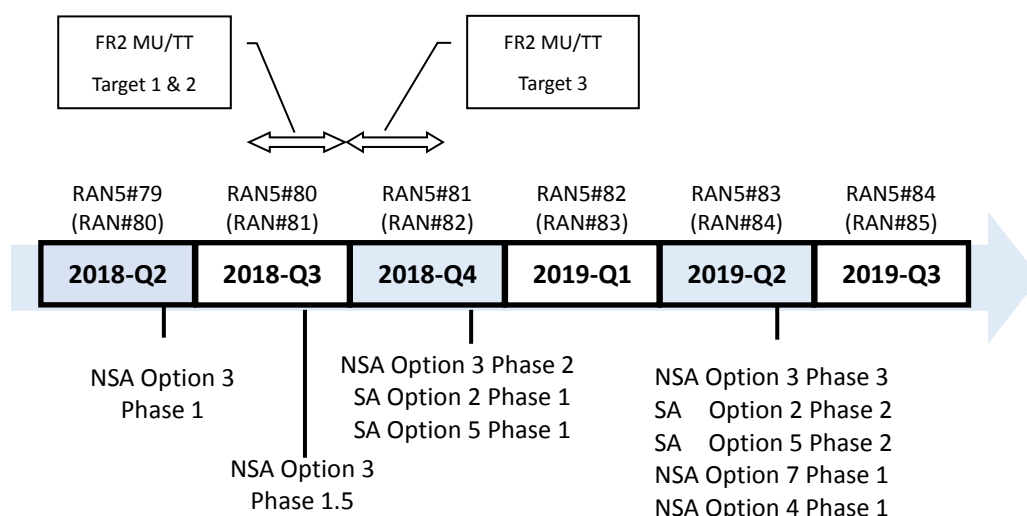

Figure 14-2 Targets for each deployment option and phase including targets for completion of Measurement Uncertainty (MU) and Test Tolerance (TT) analysis for Rx and Tx FR2 MU/TT Target 1, FR2 MU/TT Target 2 and FR2 MU/TT Target 3 test cases are indicated (see R5-182933 for definition of the different FR2 MU/TT phases).

### 14.3.2 Progress to-date

The estimated overall completion of the work item is 15% with the estimated completion per RAN-CN interface options and delivery phases shown below:

SA				NSA							
Option 2		Option 5		Option 3				Option 4		Option 7	
1	2	1	2	1	1.5	2	3	1	2	1	2
RAN5#81 (Nov-18)	RAN5#83 (May-19)	RAN5#81 (Nov-18)	RAN5#83 (May-19)	RAN5#79 (May-18)	RAN5#80 (Aug-18)	RAN5#81 (Nov-18)	RAN5#83 (May-19)	RAN5#83 (May-19)	-	RAN5#83 (May-19)	-
16%	0%	4%	0%	100%	26%	48%	1%	13%		18%	

In 2018, RAN5 will be holding three additional ad-hoc meetings in January, April and October dedicated to 5G conformance tests to ensure the targets are met.

Further updates on the 3GPP RAN5 and other associated certification bodies on 5G conformance tests will be provided in future update of this paper.

### 14.4 Risks

With any new technology, there will be the usual technical risks associated with a new design and problems encountered during the implementation. There is however some risks which are unique to the development of 5G NR.

The first major risk for 5G NR is whether the commercial service target will be met with working solutions. This is largely caused by the very tight timescale for the definition 5G specifications and the development of new devices following these specifications. For 3G and LTE, there was a period of about 4-5 years from the development of the 3GPP core specifications to the general commercial service launch. However, for 5G NR, the current plan suggests that this period will be reduced to 3 years. It means that the development of the new specifications and new devices, both user equipment and network equipment, will have to take place in parallel. The risk is particularly increased with the introduction of mmWave for the higher frequency bands. It is because mmWave is an entirely new technology for mass cellular mobile communication.

Many vendors are closely tracking the progress of the 3GPP core specifications in order to minimize the risks in developing their devices in parallel. Nevertheless, in order to meet the timescale, there will be a level of speculative development involved in trying to predict what may or may not be included in the 3GPP standards. The speculative nature means that the development team must build in flexibility in their design to allow rapid changes to be made at a later stage.

Another way to mitigate the risks is for the test equipment and the device vendors to work closely from early stages of the development. They will each independently monitor and interpret the output of 3GPP from each meeting. When working together, they can compare the understanding and cross validate with each other in order to have a better chance to arrive at a common correct interpretation. This will minimize the necessity of rework during development. It will also ensure a smoother path during the test phase.

The second key risk is the introduction of mmWave in a mass cellular communication network. mmWave as technology has been used in many high frequency applications such as satellite and short-range radio communication applications. But it has not been used in a highly dense and flexible cellular communication application where the geographical coverage will be wide and user behavior is extremely unpredictable. The industry has been doing extensive investigations on mmWave in the last few years to characterize its behavior in a cellular environment. Whilst these investigations are no doubt very valuable to assess the suitability and the risks, it is simply not possible to cover every eventual use case involved. For this and other reasons such as costs of deployment, the initial application for mmWave operation tends to focus on fixed point-to-point such as home broadband where the geographical environment can largely be pre-determined.

---

## 15 Other Aspect

GTI Sub-6GHz 5G Device Whitepaper targets enhanced Mobile Broadband (eMBB) scenario for Sub-6GHz 5G pre-commercial and commercial products, which discusses Form Factor of 5G Device, Communication Function and Performance requirements and the hot topics of 5G Device Implementation. This document conducted to be the technical references for the development of chipset/ device and the basis for the 5G pre-commercial and commercial products specs. According to the progress of 3GPP 5G NR standardization and the findings from the development and trials, there will be more key issues need to be discussed in the updated version of this Whitepaper in the next step.